

# **DRAUGHTSMAN CIVIL THEORY**

**VOCATIONAL EDUCATION**

**Higher Secondary - First Year**

A Publication under  
Government of Tamilnadu  
Distribution of Free Textbook Programme  
( NOT FOR SALE )

Untouchability is a sin  
Untouchability is a crime  
Untouchability is inhuman

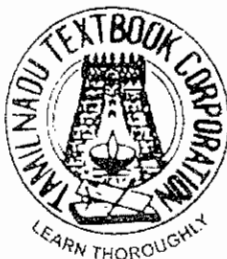

**TAMILNADU  
TEXTBOOK CORPORATION**  
College Road, Chennai - 600 006.

© Government of Tamilnadu  
First Edition - 2010

## CHAIRPERSON

**Mrs. M. SATHIAVENI**  
Chairperson  
Head of the Department (Civil)  
Central Polytechnic College,  
Tharamani, Chennai - 600 113.

## AUTHORS

**Mr. K. Senthilvelan**  
Vocational Teacher  
General Cariappa Hr. Sec. School  
Saligramam, Chennai - 600 093.

**Mrs. S. Deepa Patchiammai**  
Vocational Teacher  
NLC Girls Hr. Sec. School  
Block 11, Neyveli - 607 803.

**Mr. R. Ravi**  
Vocational Teacher  
Sengunthar Magasana Hr. Sec. School  
Tharamangalam,  
Salem Dist. - 636 502

**Mr. A. Tamilselvan**  
Vocational Teacher,  
RN. Govt. Boys Hr. Sec. School  
Aykkaran Pulam 2  
Nagai Dist. - 614 707.

**Mr. V.V. Balaji**  
Vocational Teacher  
Govt. Hr. Sec. School,  
Mettur Dam  
Salem Dist. - 636 401

This book has been prepared by The Directorate of School Education  
on behalf of the Government of Tamilnadu

**This book has been printed on 60 GSM Paper**

Printed by Offset at:

# **DRAUGHTSMAN CIVIL**

## **Syllabus for XI Standard**

### **BASIC ENGINEERING DRAWING**

#### **UNIT - I**

##### **1.1. Drawing instruments and their uses:**

Drawing - Drawing instruments - Drawing Board - Tee Square - Set Square - Protractor - Mini drafter - Clinograph - French curves - Scales - Compass - Divider - Drawing Pencil - Eraser - Paper Fasteners - Drawing Paper.

##### **1.2. Lines, Lettering and Dimensioning**

Lines - Types of Lines - Lettering - Vertical Type and Inclined Type - Dimensioning - Principles of Dimensioning - Methods of Dimensioning

### **BUILDING MATERIALS**

#### **UNIT - II**

##### **2.1 Stones**

Introduction - Classification of rocks - uses of stones - requirement of good building stones - Types of stones and their uses - Artificial stones - Types of artificial stones and their uses.

##### **2.2 Bricks**

Introduction - Definition - Size and weight of bricks - brick earth - Manufacture of bricks - Burning of bricks - Classification of bricks - Properties of good bricks - Types of bricks and their uses

#### **UNIT - III**

##### **3.1. CEMENT**

Introduction – Types of Cement – Natural Cement – Artificial Cement – Types of Artificial cement – Field Test for Cement

##### **3.2. Mortars**

Introduction - Properties of good mortar - Types of mortar - preparation of cement Mortar - Uses of mortar - precautions in using mortar - Test for mortar

##### **3.3 Concrete**

Introduction - Ingredients in concrete - Bulking of sand - Grading of aggregates - Water cement ratio - Slump test - Preparation of concrete - Hand mixing - Machine mixing - consolidation of compaction of

concrete - curing of concrete - Properties of cement concrete - uses of concrete - Types of concrete - Safety precaution to be taken.

## **UNIT - IV**

### **4.1. TIMBER**

Introduction - Uses of timber in construction - Types of timber - Defects in timber - Seasoning of timber- Objects of seasoning -Methods of seasoning of timber - Industrial timbers or Timber products.

### **4.2. Lime**

Introduction - Types of lime - Difference between Fat lime and Hydraulic lime -preparation of lime mortar.

### **4.3. Tiles**

Introduction - Types of Tiles – Drain Tiles - Floor tiles and roof tiles – Different Types of roof tile

## **BUILDING CONSTRUCTION**

## **UNIT - V**

### **5.1. Foundation**

Introduction - object - Types of Foundation - Shallow foundation - Deep foundation - Causes of failure of foundation.

### **5.2. Stone Masonry**

Introduction - Terms used in Stone masonry – Dressing of stones - Classification of stone masonry - Tools used in stone masonry and their uses.

### **5.3. Brick Masonry**

Introduction - Terms used in brick masonry -Types of Bonds - Tools used in brick masonry and their uses - Difference between Stone masonry and Brick masonry

## **UNIT - VI**

### **6.1. Lintels and Arches**

Introduction - Terms used in Arches - Types of Arches - Lintels - Classification of lintels - Difference between Arches and Lintels.

### **6.2. Carpentry and Joinery**

Introduction - terms used in carpentry - principles governing the construction of joints - Types of wooden joints

### **6.3. Doors and Windows**

Introduction - Terms used in Doors and windows - sizes and location of Doors and windows - Types of Doors - Types of windows - Fixtures for doors and windows Hinges, Bolts and Locks.

## **UNIT - VII**

### **7.1. STAIRS**

Introduction - Terms used in stairs - Location of stairs - Types of stairs-Requirements of stairs - Escalators

### **7.2. Floors and Flooring**

Introduction - Quality of good floors - Factors which govern the selection of type of floor- Classification of flooring – Types of Materials used for flooring - Floor finishing and floor covering.

## **UNIT - VIII**

### **8.1. AUTO CAD**

Introduction - Advantages of using AUTOCAD - Uses drafting in AUTOCAD - Commands - Limits - Function Keys - File management – Drawing Commands

### **8.2. AUTO CAD CONTINUATION**

Modify or Edit commands - Zooming Options -Dimension Managements – Layer – Editing Commands - Isometric drawing - Orthographic Projection.

## **PREFACE**

The task of Engineering studies is sky High. For which Civil Engineering students should have the relevant books for their need. Civil Engineering is a Universal Subject and no Government function without this faction.

Imparting Technical Education in school level have been started in 1978. Draughtsman Civil and Building Maintenance are combined in this book.

Basic Engineering Drawing, Building Materials and Practice and AUTO CAD are interlinked in one day to day life.

Understanding the concept of Civil Department syllabus, this book has been prepared in detail in each chapter with due importance are given to clear diagrams and questions.

Now the situation has changed by imparting Technical Education only through Engineering Colleges. At present, students who have studied in Vocational groups are deserved to admission at Polytechnic and Job opportunity are bright.

I must sincerely convey my thanks esteemed to the school Education Director and Joint Director whose partonage on this book to comeout and the committee of learned Teachers who sholdered the responsibility to bring the book in good shape.

The student community will appreciate and take lead of the task to modern world.

**M. SATHIAVENI**

Chairperson

# CONTENT

## Basic Engineering Drawing

### Unit 1

- |   |         |
|---|---------|
| 1.1. Drawing Instruments and their Uses   | 1 - 14  |
| 1.2. Lines and Lettering and Dimensioning | 15 - 28 |

## Building Materials

### Unit 2

- |             |         |
|-------------|---------|
| 2.1. Stones | 29 - 35 |
| 2.2. Bricks | 36 - 50 |

### Unit 3

- |               |         |
|---------------|---------|
| 3.1. Cement   | 51 - 56 |
| 3.2. Mortars  | 57 - 62 |
| 3.3. Concrete | 63 - 72 |

### Unit 4

- |             |         |
|-------------|---------|
| 4.1. Timber | 73 - 83 |
| 4.2. Lime   | 84 - 99 |
| 4.3. Tiles  | 90 - 94 |

## Building Construction

### Unit 5

- |                    |           |
|--------------------|-----------|
| 5.1. Foundation    | 95 - 108  |
| 5.2. Stone Masonry | 109 - 123 |
| 5.3. Brick Masonry | 124 - 139 |

## **Unit 6**

<b>6.1. Arches and Lintels</b>	<b>140 - 150</b>
<b>6.2. Carpentry and Joinery</b>	<b>151 - 156</b>
<b>6.3. Doors and Windows</b>	<b>157 - 178</b>

## **Unit 7**

<b>7.1. Stairs</b>	<b>179 - 187</b>
<b>7.2. Floors and Flooring</b>	<b>188 - 199</b>

## **Unit 8**

<b>8.1. Auto CAD</b>	<b>200 - 216</b>
<b>8.2. Auto CAD Continuation</b>	<b>217 - 248</b>



# UNIT-I

## BASIC ENGINEERING DRAWING

### 1.1. DRAWING INSTRUMENTS AND THEIR USES

#### 1.1.1. DRAWING

If an object is drawn in a paper and the representation is called drawing.

Drawing is classified into three parts

- 1) Art Drawing
- 2) Geometrical Drawing
- 3) Engineering Drawing

#### 1. Art Drawing

The shape of objects of the universe like (Trees, Animals, hills, natural sceneries etc..) are drawn in a paper and the representation is called Art Drawing.

#### 2. Geometrical Drawing

The Geometrical related objects (Square, Rectangle, Triangle cylinder, sphere) is drawn and the representation is called Geometrical Drawing.

#### 3. Engineering Drawing

The Engineering related material (Building machine electrical fittings etc..) are drawn and shown in a paper is called Engineering Drawing.

#### 1.1.2. DRAWING INSTRUMENTS

In the faculty of Engineering to draw a drawing in a simple way and to a accuracy there are so many drawing instruments are used.

#### 1.1.3. DRAWING BOARD

Drawing board is rectangular in shape. They are made up of soft and light wood of white colour Pine, Oak and Linoleum. To avoid cracks in the board they are joined by Tongue and Groove joints. The top portion of the board is uniform. A straight ebony edge is joined at the edge of the board and it is cross to Board plane. The head of the 'T'-square is fitted accurately at the ebony edge of Drawing board and it can be moved front and back according to the necessity.

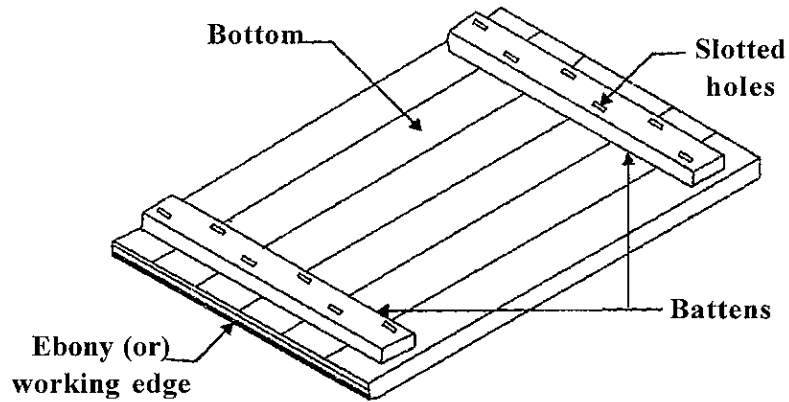

**Fig. 1.1.1. Drawing Board**

Drawing Board is available in several dimensions. The size of drawing board varies according to the size of drawing sheet.

According to Indian standard Institutions (IS-1444-19970 the recommended size of drawing board is given below.

Name of Board (or) Designation	Size of Drawing sheet to be used	Length x Breadth x thickness of Board size (mm)
D <sub>0</sub>	A <sub>0</sub>	1500 x 1000 x 25
D <sub>1</sub>	A <sub>1</sub>	1000 x 700 x 25
D <sub>2</sub>	A <sub>2</sub>	700 x 500 x 15
D <sub>3</sub>	A <sub>3</sub>	500 x 350 x 15

In college and school D<sub>2</sub> size drawing board is used.

#### 1.1.4. T-SQUARE

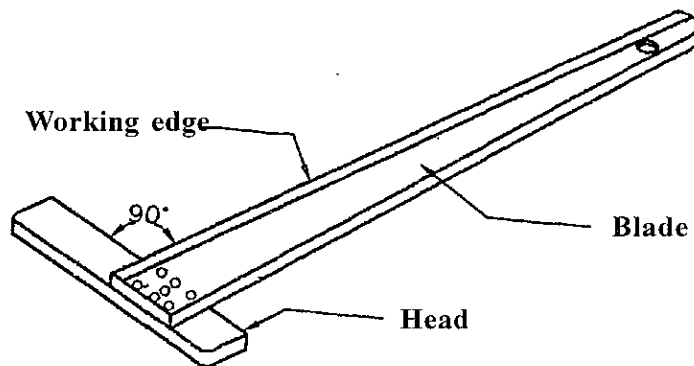

**Fig. 1.1.2 T-square**

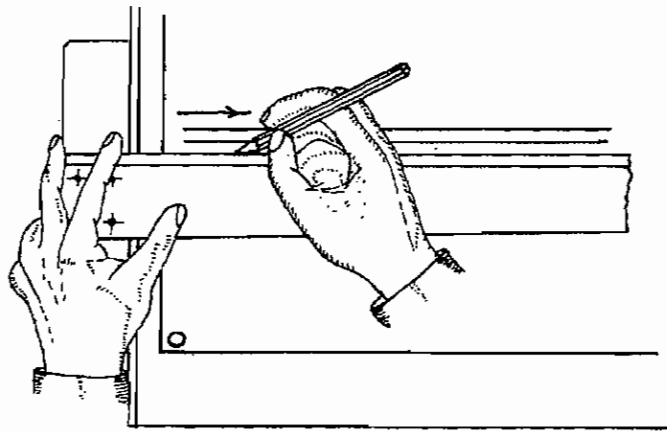
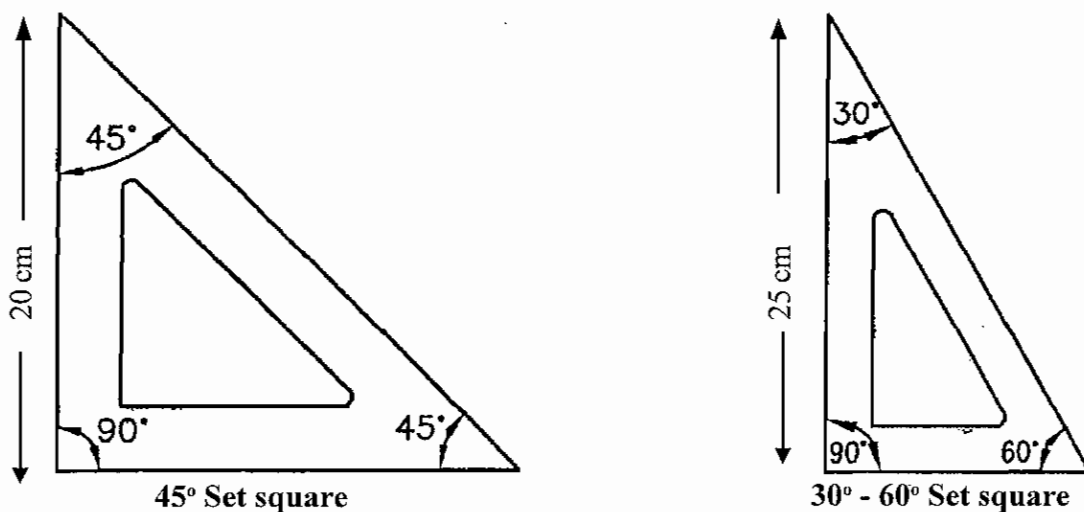

**Fig. 1.1.3. Using 'T' Square**

T-square is made up of hard wood or plastic. There are two parts called Blade and Head or stock. One edge of the stock is made uniform to draw the line conveniently. This is called working edge. The inner edge of the board is an another working edge. The angle of the both working edge joined at 90 degrees. The working edge of the blade is pressed on the ebony edge of drawing board and moved to top and bottom of drawing board. The horizontal line and vertical lines are drawing by using 'T'-square.

### **1.1.5. SET SQUARES**

Set squares are made up of transparent celluloid (or) plastic. They are available in two types. The set square is triangular in shape one of the angle is  $90^\circ$ . The set square of  $30^\circ$ - $60^\circ$  is of length 25 cm., The set square  $45^\circ$  is 20 cm in length. The edge of the set square is convenient to draw uniform line. In general the centre point of set square is provided with triangular hole or French curve. The measurements are noted on the side of the right angle portion of the set squares.



**Fig. 1.1.4. Set Squares**

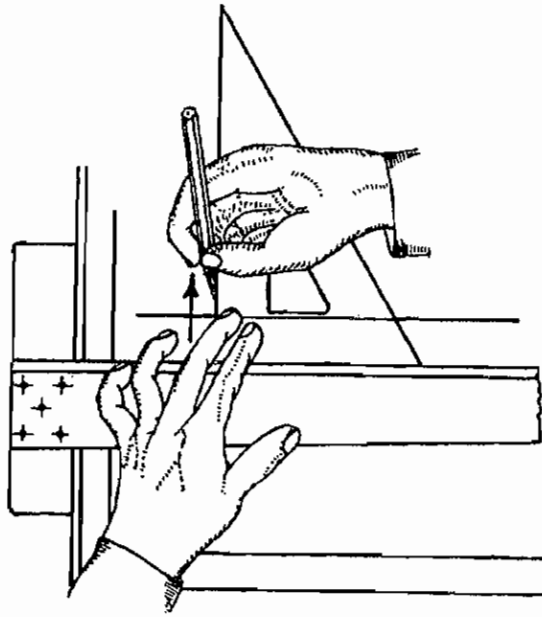

**Fig. 1.1.5. Using Set square**

Vertical line and inclined line are drawn by set square with the help of 'T' square.

### 1.1.6. PROTRACTOR

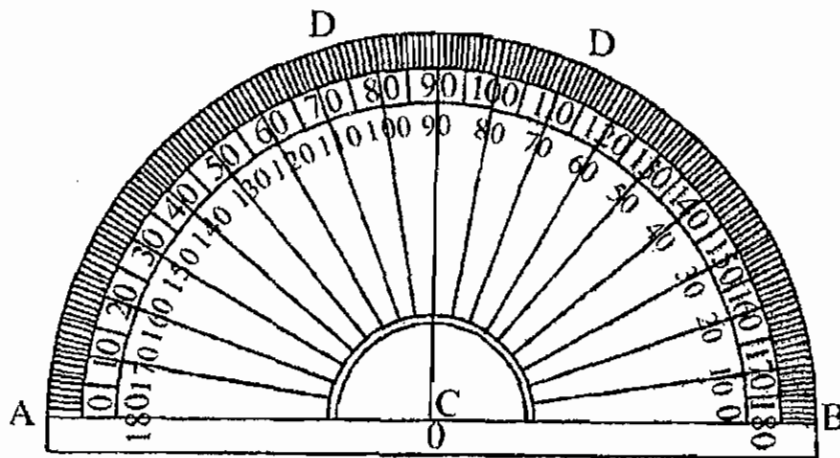

**Fig. 1.1.6. Protractor**

Protractor is made up of transparent celluloid (or) Plastic. Generally the protractor is in the shape of flat semi circle (or) circle with 100 mm diameter. The angle are marked to  $1^\circ$  accuracy at the circumferential edge. They are marked at  $10^\circ$  intervals in the clockwise and anti clockwise direction. The straight line joining  $0^\circ$  to  $180^\circ$  is called the base of the protractor.

To the 'O' point of baseline a vertical line is drawn.

To measure the possible and impossible angles and lines the protractor is used. By using the protractor the circle can be divided into equal parts.

### 1.1.7. MINI DRAFTER

A simple and small shaped instrument of the drafting machine is called Mini Drafter. Now-a-days these are mostly used by the engineering students. All the working functions of set square protractor, scale and their merits and usage are co-ordinated in a mini-drafter.

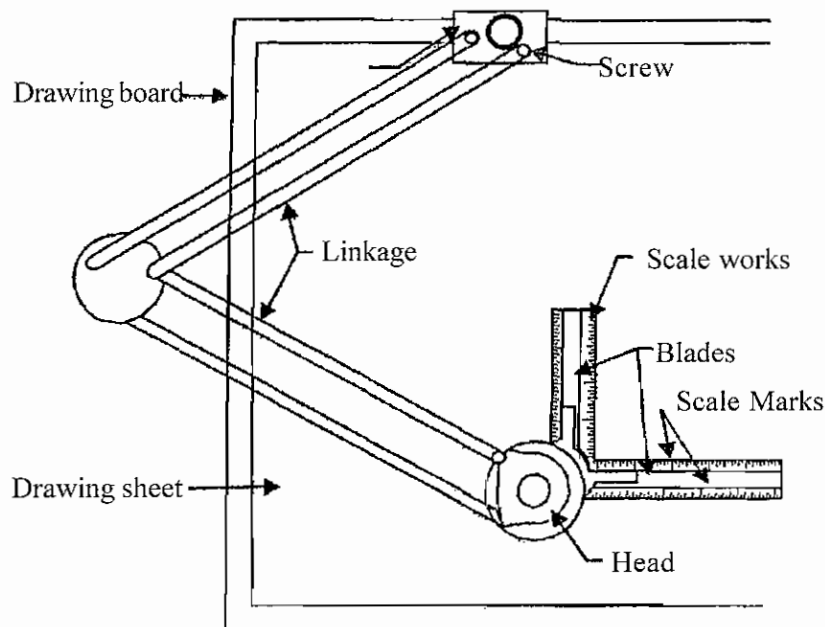

**Fig. 1.1.7 Mini Drafter**

There are two blades (same element). Two edges are in vertical angle. conveniently the blade is connected to the head. In this head a protractor is marked with angles. This is either in aluminum (or) Plastic. The blade is lifted according to required angle. It can be fixed firmly after the adjustment. The blades are made up of transparent plastic. Parallelogram bars are made up of steel plate or rods.

The head and blade are connected with parallelogram bars with a screwed knob. The screwed knob can be fixed to the convenient place on any edge of the drawing board. This connecting technique helps the blade by tilting it to the whole area of drawing board. The blade moves where ever on the drawing board is parallel to its old position. Measurements are marked on the blade. The horizontal line, vertical line, inclined line can be drawn on the drawing sheet simple and to the required length with the help of mini drafter.

### 1.1.8. CLINOGRAPH

An adjustable set square which changes angular measurement is known as clinograph. These are made up of transparent plastic (or) celluloid. This is in the form of channel. As shown in the figure a lengthy strip with L shape of  $90^\circ$  is joined with straight small strip. Provision to move the strip is made by centering the hinge. This strip can be adjusted to any required inclined angle. With this clinograph 'T' square is used and parallel lines are drawn to any inclined line.

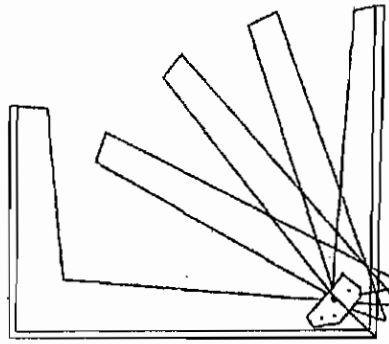

**Fig. 1.1.8. Clinograph**

### 1.1.9. FRENCH CURVE

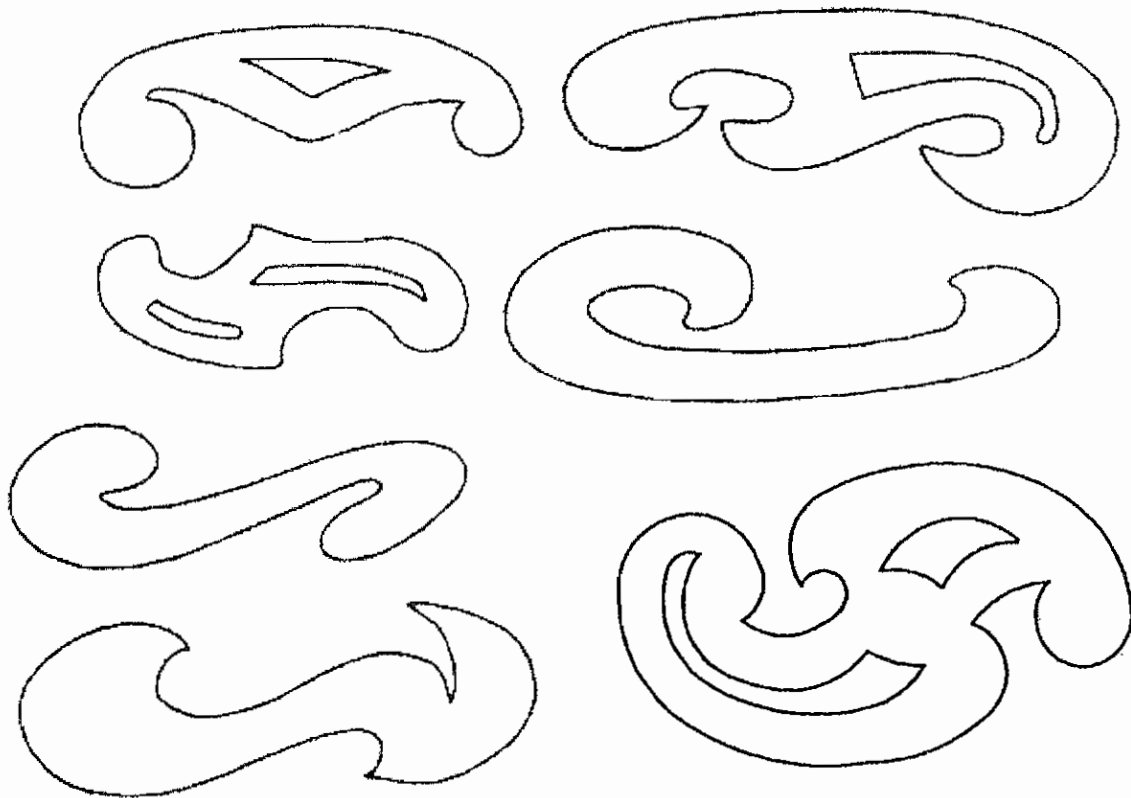
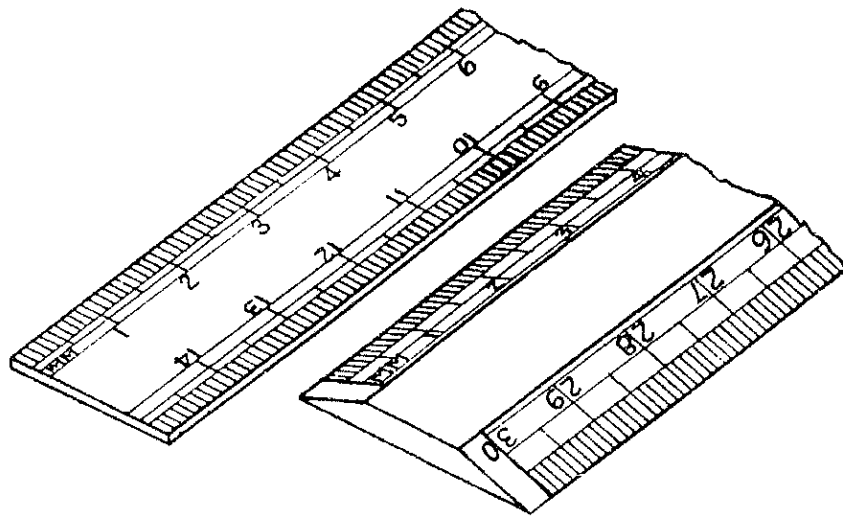

**Fig. 1.1.9. French curves**

These are made up of transparent plastic. The structure is shown in Figure. Where it is impossible to draw the irregular curved line with compass can be drawn by using this French curve.

### 1.1.10. SCALE

The scale is made up of wood, transparent celluloid (or) plastic. Metric (or) British system of Measurement is marked on the edge of the scale. Generally the size of scale we are using is 300 mm length, 30 mm breadth and 1 mm thickness. The measurement are graduated in 1:1 scale.



**Fig. 1.1.10. Scales**

### **1.1.11. COMPASS**

Two types of compass are in a geometry box.

- 1) Bow compass
- 2) Large compass.

#### **1. BOW COMPASS**

These are used to draw small circle upto 25 mm and to draw arc. These are made up by the metal of steel. Upper part of the leg is provided with a small deviation by a pressing spring. A sharp needle is joined at the other end. The other leg has the provision of fixing the pencil lead. In between the legs or at the side of the leg. There will be adjusting screw is fixed in this compass.

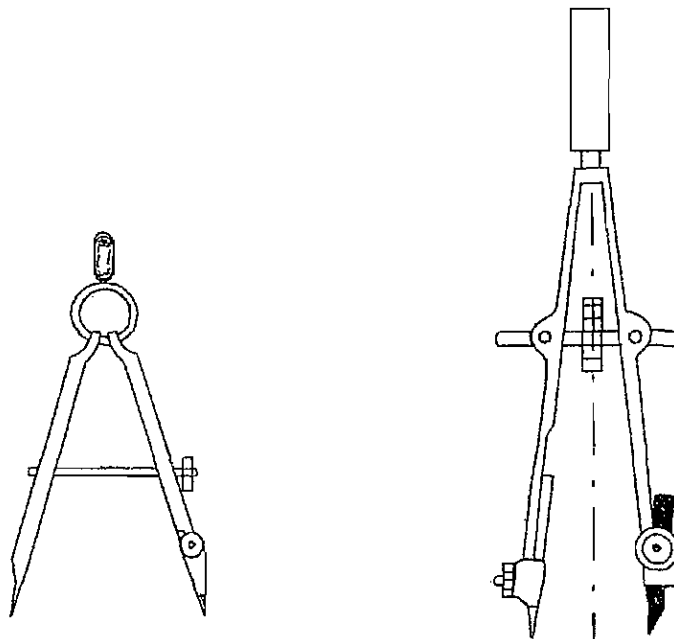

**Fig. 1.1.11. Bow Compass**

## 2. LARGE COMPASS

These are made up of steel. They are used to draw diameter of 120 mm circle and arc. The upper part of the leg is connected with pivot.

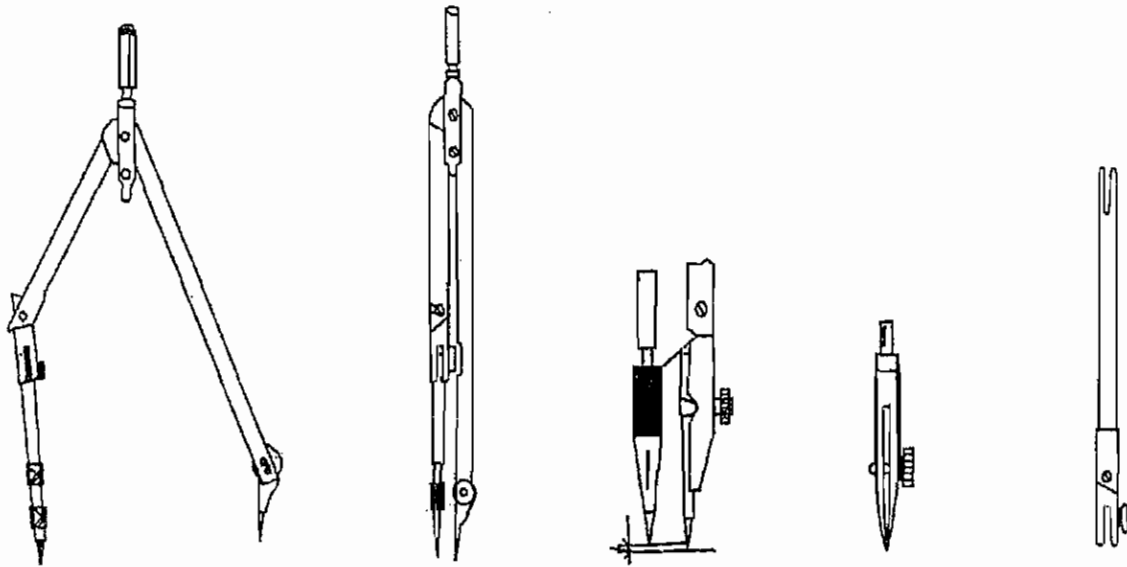

**Fig. 1.1.12. Large Compass**

A sharp needle in fixed is one of the end. The length of the sharp needle can be changed to the required measurement with the help of the adjusting screw. The other one has the provision of fixing the pencil lead. Instead of pencil, lead ink pen can be fixed. The pencil lead and the sharp needle are made vertical to the drawing sheet, when diameters of big circles can be drawn. Above 120 mm the circle may be drawn by fixing the lengthening bar at the leg where the pencil lead is fixed.

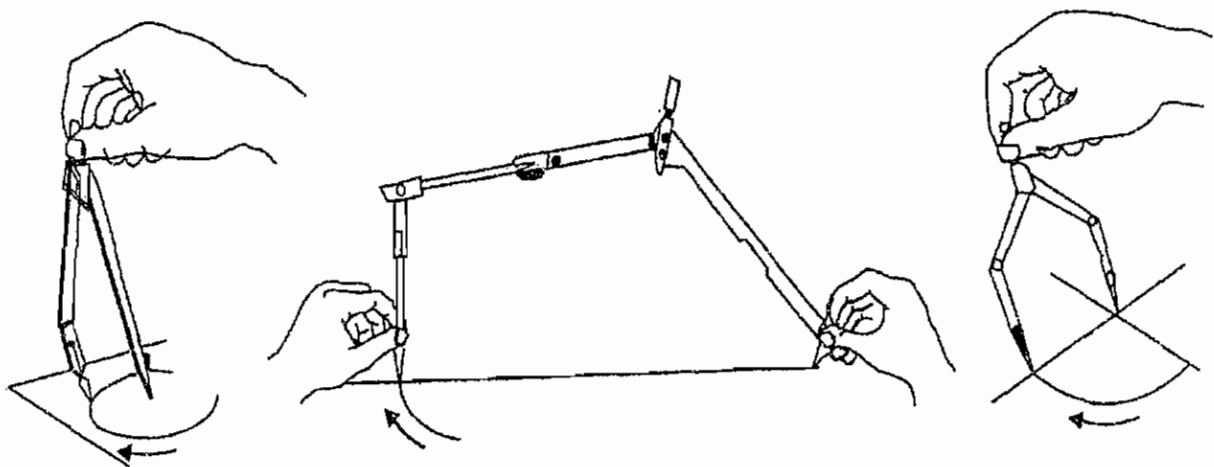

**Fig. 1.1.13. Using large compass lines**



### 1.1.12. DIVIDER

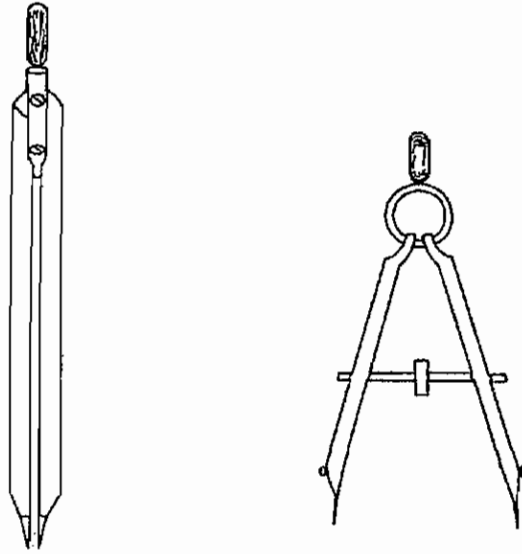

**Fig. 1.1.14. Divider**

These are made up of steel. The upper portion of the two legs are connected by a pivot. The other ends are like sharp needle. According to our requirement the curve (or) straight line can be divided in to equal parts with the help of divider. Measurement may be transferred from scale to drawing. Distance of one figure measured can be drawn to another figure.

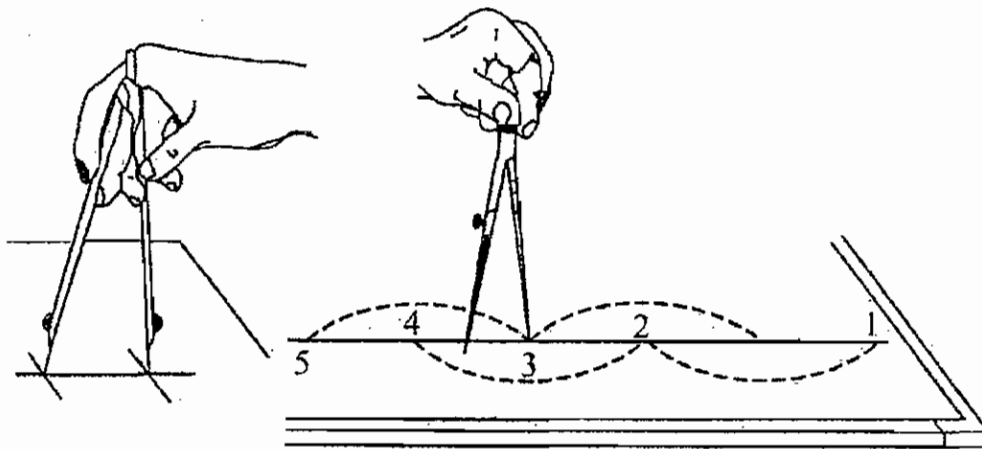

**Fig. 1.1.15. Using Divider**

### 1.1.13. DRAWING PENCIL

Quality of drawing, accuracy, appearance depends upon the quality of pencil which are used. So to draw a drawing, only drawing pencil can be used. So many qualities are available in drawing pencil. The quality of pencil is marked at one end. There are 18 qualities in drawing pencil. The pencils used for engineering drawing and their qualities are given below.

- 1) Hard pencils (9H to 4H)
- 2) Medium hard pencil (3H, 2H, H, F, HB and B)
- 3) Soft pencils (2B to 7B)

To complete a drawing we have to use several types of lines. Grades of pencil are used to draw the required lines which are given below.

<b>Pencil Grade</b>	<b>Use</b>
3 H Pencil	Construction lines
2 H Pencil hidden lines.	Dimension lines, Centre line, Sectional lines, leader lines,
H Pencil	Object lines, lettering
HB pencil instruments	To write the measure of dimension, Boundary line to draw

We should not sharpen the end of the quality of pencil marked. The other end of the pencil is sharpend in any one of the method as shown in the figure.

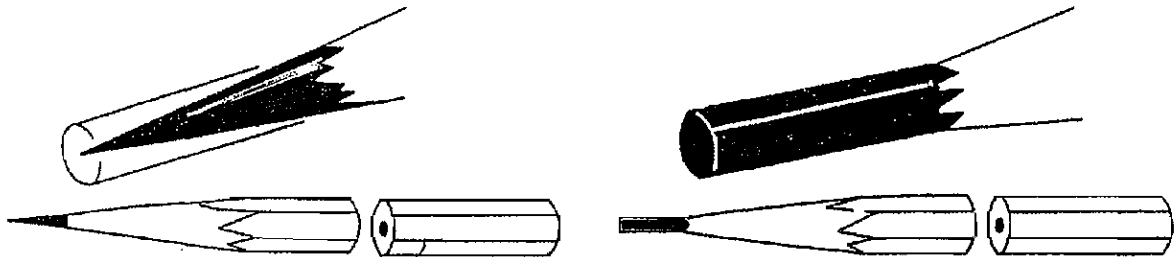

**Fig. 1.1.16. Drawing Pencil**

#### **1.1.14. ERASER**

These are prepared by soft Rubber. Extra lines and lines drawn by mistake are erased by using the rubber. The rubber we are using should not be damage the drawing sheet. After erasing the rubber, crumbs formed are cleaned by using a cloth.

#### **1.1.15. PAPER FASTENERS**

Following materials are used to fix the drawing sheet on the drawing board.

- 1) Thumb pins
- 2) Cello taps
- F3) Fold back gap spring clip.

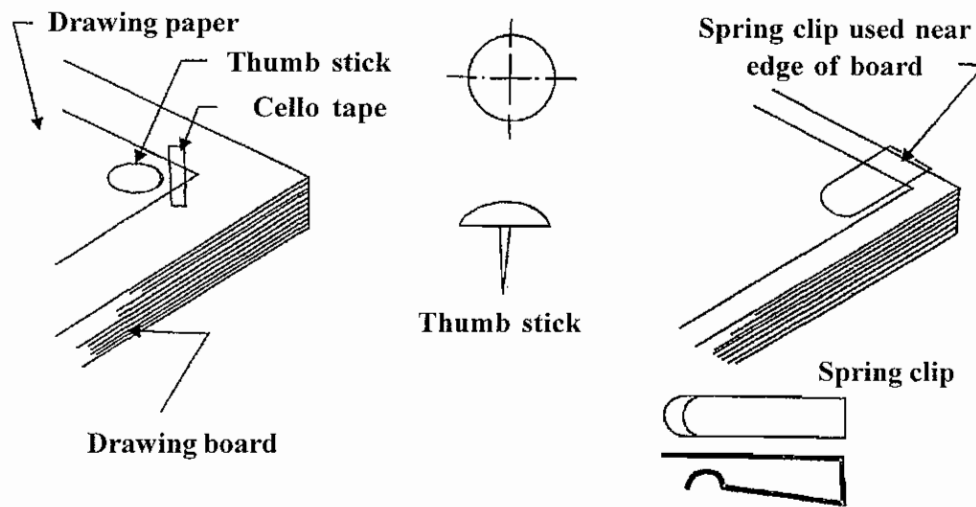

Fig. 1.1.17. Paper Fasteners

### 1.1.16. DRAWING PAPER

Drawing sheets are available in various qualities. The drawing sheet used for drawing should be white, uniform thickness and not easily torn. While using the rubber the fibres of paper should not come out. Surface of a good quality drawing sheet should be soft. The drawing should be drawn on the soft side. According to the size of drawing sheet also varies and are available in various dimensions.

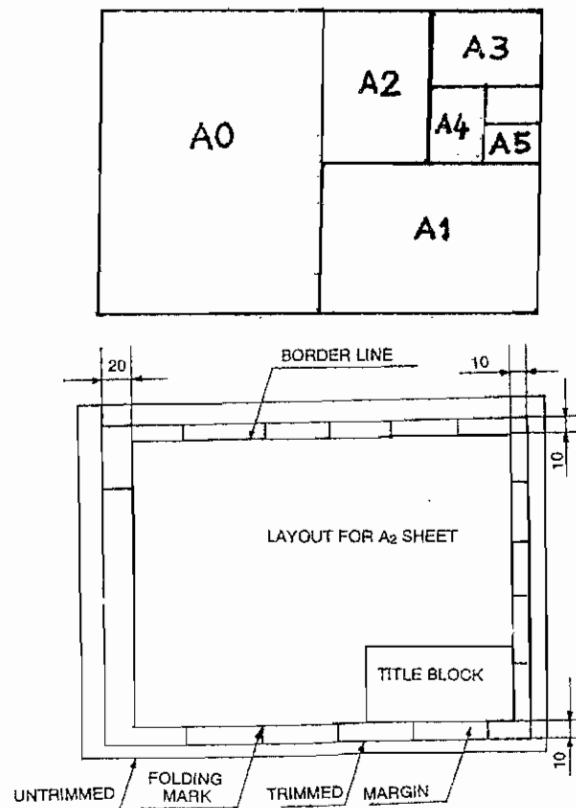

Fig. 1.1.18. Drawing Paper

Drawing sheets recommended by Indian Standard Institutions (IS: 10711-1983) are given below.

<b>Serial No.</b>	<b>Name of sheet</b>	<b>Trimmed size (mm) length x width</b>
1	A <sub>0</sub>	841 x 1189
2	A <sub>1</sub>	594 x 841
3	A <sub>2</sub>	420 x 594
4	A <sub>3</sub>	297 x 420
5	A <sub>4</sub>	210 x 297
6	A <sub>5</sub>	148 x 210

## QUESTIONS

### PART - A

#### I. Choose the best answer

- 1) Drawing related to geometry is  
a) art drawing      b) Geometry drawing,      c) Engineering drawing      d) Civil drawing.
- 2) Drawing related to engineering is  
a) Engineering drawing      b) Civil drawing  
c) Geometry drawing      d) Art drawing.
- 3) Use of 'T' Square.  
a) used to draw curved line,      b) used to measure length  
c) used to measure angles      d) used to protractor and set square
- 4) The length of 30° to 60° set square.  
a) 30 cm      b) 35 cm      c) 15 cm      d) 25 cm
- 5) The lines are equally divided with the help of  
a) divider      b) compass      c) set square      d) protractor
- 6) The quality of pencil used to draw object lines.  
a) 2 H      b) 3 H      c) HB      d) H
- 7) The total number of quality drawing pencil.  
a) 6      b) 12      c) 18      d) 3
- 8) Combined instrument of 'T' square, set square, protractor and scale.  
a) Mini drafter      b) French curve      c) Compass      d) Chinograph

### PART-B

#### II. Answer in one (or) two words

- 1) What is the use of Protractor?
- 2) What is the length and breadth of the scale generally used.
- 3) What is the size of drawing board used in college and schools.
- 4) What is the shape of drawing board.
- 5) How the angles degree are marked in the semi circular protractor.

## **PART - C**

### **III. Answer in one (or) two sentences**

- 1) What is meant by art drawing.
- 2) What is meant by Engineering drawing.
- 3) What is meant by Geometrical drawing.
- 4) Mention any four instruments to draw the drawing.
- 5) What are the instruments used to draw curved lines.
- 6) What is the use of compass.
- 7) What is the use of 'T' square.
- 8) Mention any two prescribed size of drawing board.
- 9) What is the use of set square.
- 10) What is the use of Chinograph.

## **PART-D**

### **IV. Answer shortly**

- 1) Draw the sketch of drawing board and mention the parts.
- 2) What is the difference between 'T' square and set square.
- 3) What is meant by French curve and mention the uses.
- 4) Draw the Fig. of divider used for measurement and describe it.
- 5) Describe the protractor with a sketch.

## **PART-E**

### **V. Answer in detail**

- 1) Describe the mini drafter with a neat sketch.
- 2) Describe any four equipments used for drawing with a neat sketch.
- 3) Describe the pencil used for drawing with a neat sketch.

# 1.2 LINES LETTERING AND DIMENSIONING

## 1.2.1. LINES

In Engineering Drawing several lines are followed to define a shape of the object. Each and every line has its individual name and sense. Especially the types of lines, how each and every lines are used in Engineering drawing must be known.

## 1.2.2. TYPES OF LINES

### 1. Object line or Outline

When we see an object the visible edges and their surface boundaries are drawn in a drawing, by using this lines to show the shape of the object. To draw this line H pencil is used, and it should be thick and at the same time thin.

### 2. Hidden Lines (or) Dotted lines

These lines are used to show the hidden planes and hidden edges of an object. The length of this line may be 2 mm to 3 mm. The interval between the lines should be 1 mm. The point of intersection of these lines with the outerlines (or) another hidden line should be clearly shown.

### 3. Centre line

The centre point of arc, circle are denoted by this line. The axes of symmetrical geometrical object and cylinder, sphere, cone are denoted by this line. Construction of this line is with uniform interval of alternative lengthy line and small line. Interval is 1 mm length of the line is 9 to 12 mm and length of small line is 1.5 mm.

### 4. Dimension Line

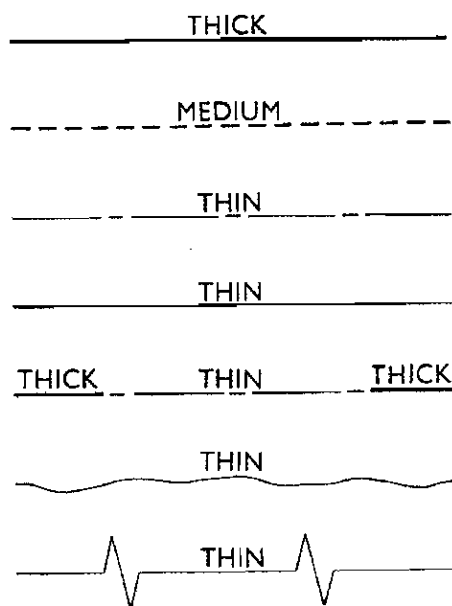
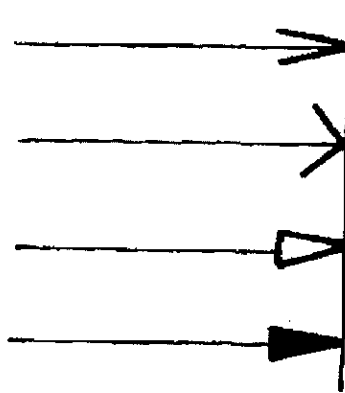

Fig. 1.2.1. Types of lines

The measurement (or) dimension of an object is denoted by using this line. This is a continuous thin line. There is an arrow at both ends of this line.

### 5. Arrow Heads

At both ends of the dimension line the arrows are marked. Arrow marks are drawn as per the sketch shown. But same type of arrow mark should be used in a sketch. The angle between the arrow mark may be  $15^\circ$  to  $90^\circ$ .



**Fig. 1.2.2. Arrow Heads**

As shown in the figure small inclined line (or) 3 mm dia small circle may be drawn at the end of dimension line instead of arrow heads.

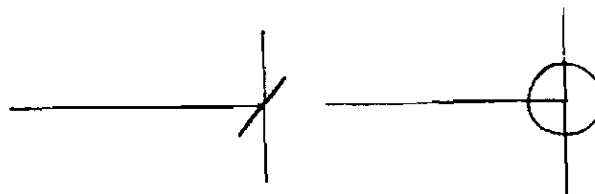

**Fig. 1.2.3. Arrow Heads**

If there is no arrow head in the dimension line they may be shown at the outside of dimension line as shown.

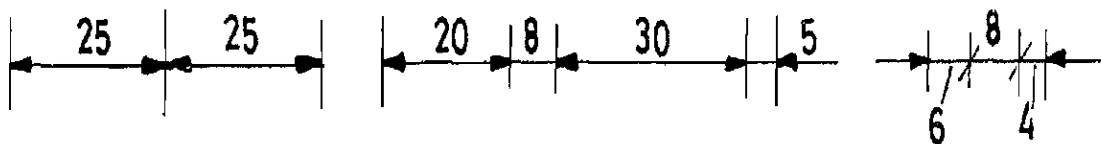

**Fig. 1.2.4. Arrow Heads**

### 6. Extension line (or) Projection line

The vertical line drawn to the portion of dimension line is called Extension line. These lines are drawn as inclined, as shown in the figure included lines should be parallel to each other.



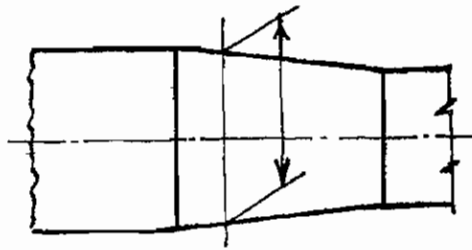

Fig. 1.2.5. Extension Line

### 7. Leader line

This line is drawn to show a particular portion of a drawing. An arrow (or) dot will be there in one end of leader line. These denotes the described portion in a drawing. Other end is a horizontal line as shown in fig. In this required data's are written horizontally.

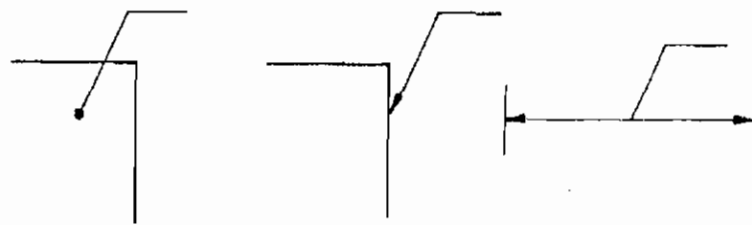

Fig. 1.2.6. Leader line

### 8. Cutting-plane line

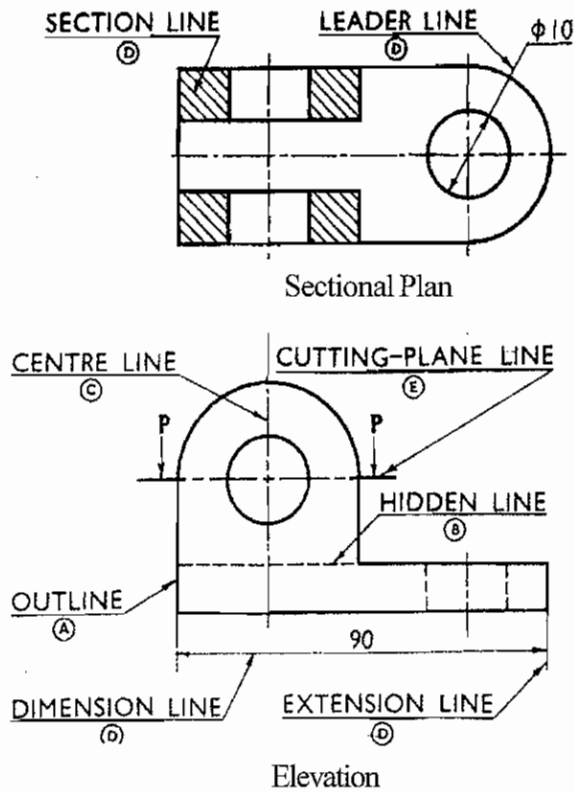

Fig. 1.2.7. View of types of lines

Imaginary line used to cut an object in a drawing is called Cutting plane line. Ends and change in direction of this line provided with thick line. Intermediate line is provided with centre line.

### 9. Sectional line (or) Hatching Line

These lines are used to note the section of solid objects when cross sections are drawn. These are at equal interval either to right or left of the horizontal section with 45°.

### 10. Short break line

These lines are used to show the lengthy object in Zig-Zag representation. Also to show the boundaries of irregular boundary object in a drawing. This line is also used to show the cut section of an object.

### 11. Long Break line

These lines are used to show the Zig-Zag representation of a lengthy object.

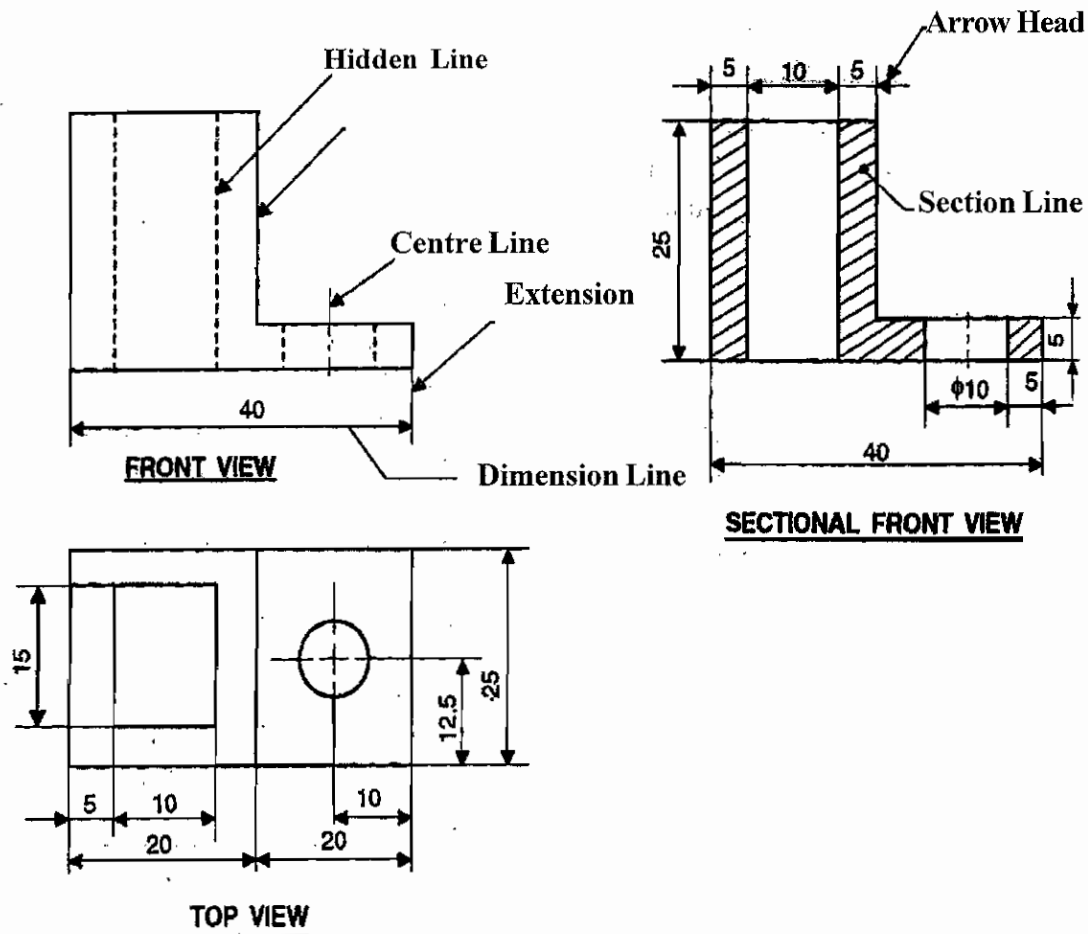

Fig. 1.2.8. Other view of types of lines

Following table shows the recommendations of the thickness of various lines by I.S.I.

Thickness	Type of line	Thickness in mm		
Thick	Object line	1.00	0.80	0.60
	Cutting plane line			
	Short break line			
Medium	Hidden line	0.50	0.45	0.40
Thin	Centre line	0.30	0.25	0.20
	Dimension line			
	Extension Line			
	Long Break line			
	Construction Line			

### 1.2.3. LETTERING

Letters and numerals are used in Engineering Drawing to specify the measurement of object and description of that object H or HB pencils are used to write letters and numerals.

Capital letters are generally used in Engineering Drawing. But small letters recommended by International standard are also used.

To write letters and Numerals, Drawing instruments should not be used, because fastness cannot be achieved. Also it takes more time. So letters and Numerals should be written without the help of Drawing Instruments, Fast lettering should be practiced.

Eventhough the drawing is drawn beautifully and the drawing can get a good appearance only if the letters and numerals are good. Generally letters and numerals are written in two methods.

- 1) Vertical type
- 2) Inclined type.

#### 1. Vertical Type

In vertical type of lettering, the letters and numerals should be written perpendicular to the horizontal level.

#### 2. Inclined Type

In this type letters and numerals should be inclined to 75° horizontal level.

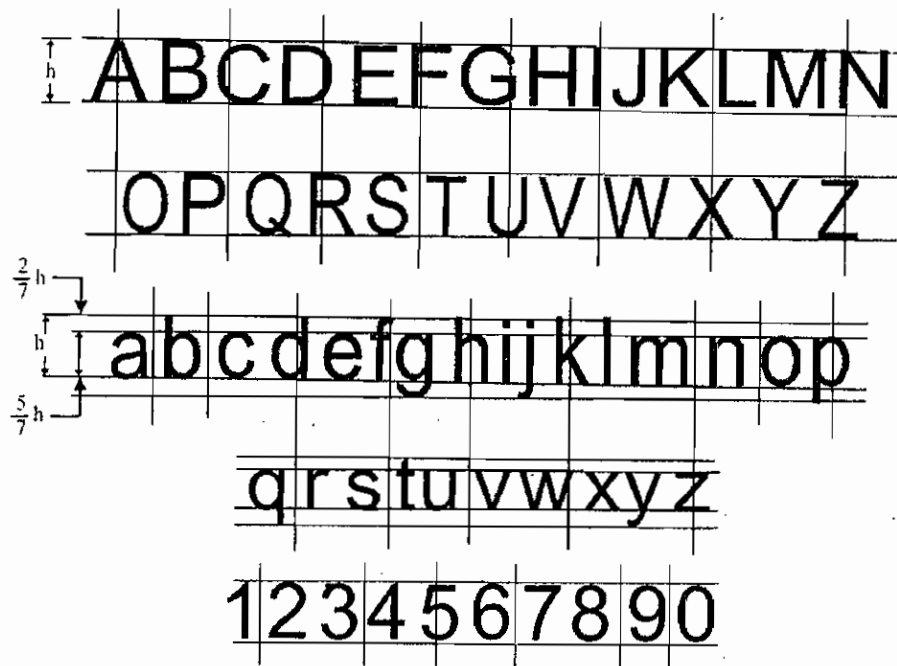

Fig. 1.2.9. Vertical line

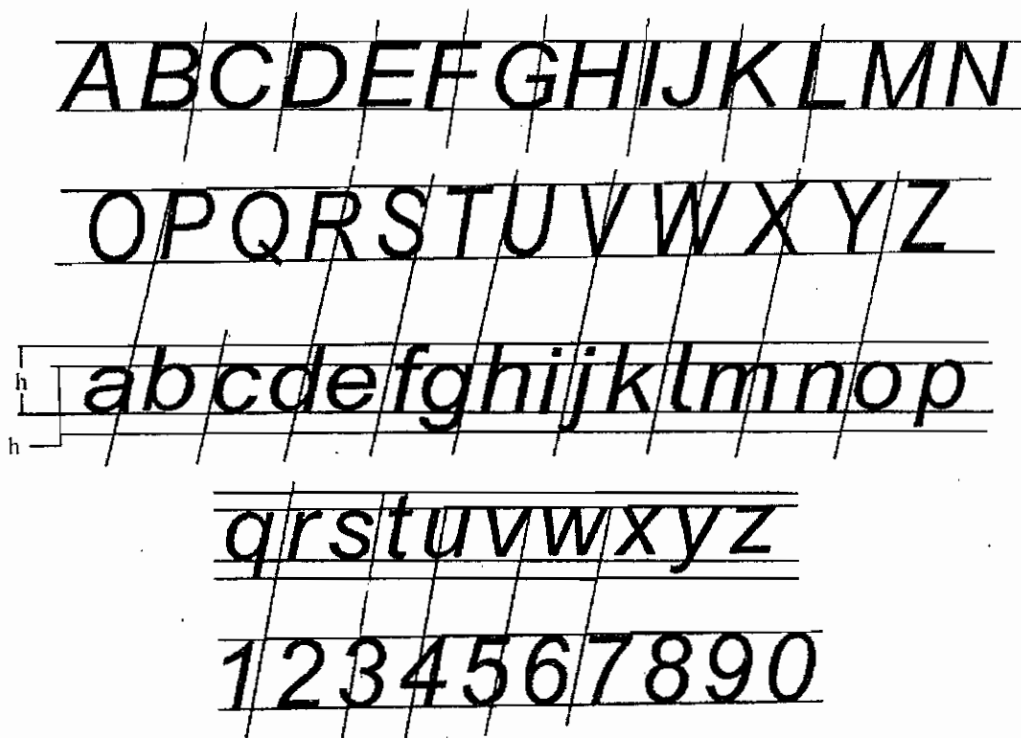
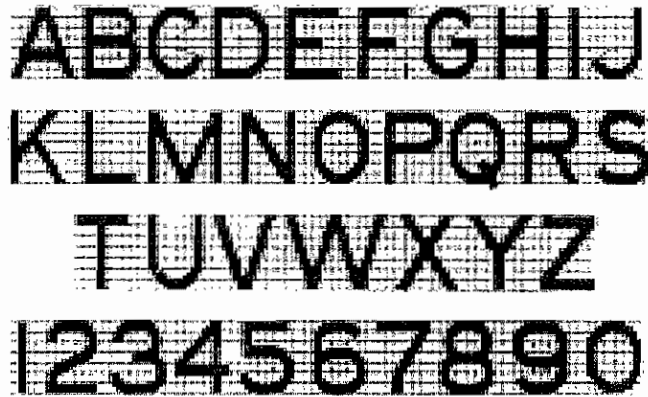

Fig. 1.2.10. Inclined line

As per IS:9609-1983 the letters and numerals are written according to their heights.

All the letters are not equal in width. Width varies according to the letters. See the shape of the letters and numerals as shown.



**Fig. 1.2.11. Lettering**

Height of letters used in Engineering Drawing is prescribed below.

2.5 – 3.5 – 5 – 7 – 10 – 14 & 20 mm.

**I.S. Recommended Sizes of Letters and Numerals**

S. No.	Item	Size of Letters and Numerals Height in mm
1.	Drawing number is title block and letters denoting cutting plane section	10, 14
2.	Title of Drawing	5, 7
3.	Sub - Titles and headings	3.5, 5, 7
4.	Notes, Such as legends, schedules, material list dimensioning	2.5, 3.5, 5
5.	Alternation entries and the tolerance	2.5, 3.5

**1.2.4. DIMENSIONING**

Method of describing the shape, measurement of an object in Engineering Drawing is called Dimensioning. So many lines, letters, numerals and symbols are used in this dimensioning.

## Principles of Dimensioning

- 1) So far all measurements should be noted outside of the drawing.
- 2) Interval of first dimension line drawn from object line is 12 mm and the interval between the next two continuous dimension lines drawn is 10 mm.
- 3) So far construction of dimensioning should be provided on the same line continuously.
- 4) Extension line drawn should be continuous from object line.
- 5) The arrow mark should touch the extension line perfectly.
- 6) Extension line should be projected downwards 3 mm from Arrow mark.
- 7) Dimension line and extension line should not cross each other. It can be avoided by constructing the large measurement below the small measurement.
- 8) No other line should be cross dimension line.
- 9) Extension lines may cross each other. Extension line may cross object line in unavoidable situation.
- 10) Lengthy objects are shown as braked in drawing. But while dimensioning the line should be shown without any break.
- 11) Same measurement should not be denoted in two views Should not draw extra lines in the drawing.
- 12) Dimensioning should not be on the basis of hidden lines.
- 13) Object line extension line and centre line should not be used as dimension line.
- 14) Only when centre line passing the centre of the circle (or) centre of cylinder. It can be used as extension line.
- 15) When dimensioning is carried out in joint dimension method measurements may be written random.
- 16) Notes are written horizontally.
- 17) Dimension line should not cut the numerals of dimension.
- 18) Measurements are written in the centre of dimension line and should not touch dimension line.
- 19) Dimensioning is constructed by noting the diameter of circle and radius of arc. Initially  $\phi$  (or) R is noted as significance when dimensioning like that (Eg.  $\phi$  30 R20).
- 20) Whatever may be the scale followed in drawing the original measurements of the object should be noted in dimensioning.

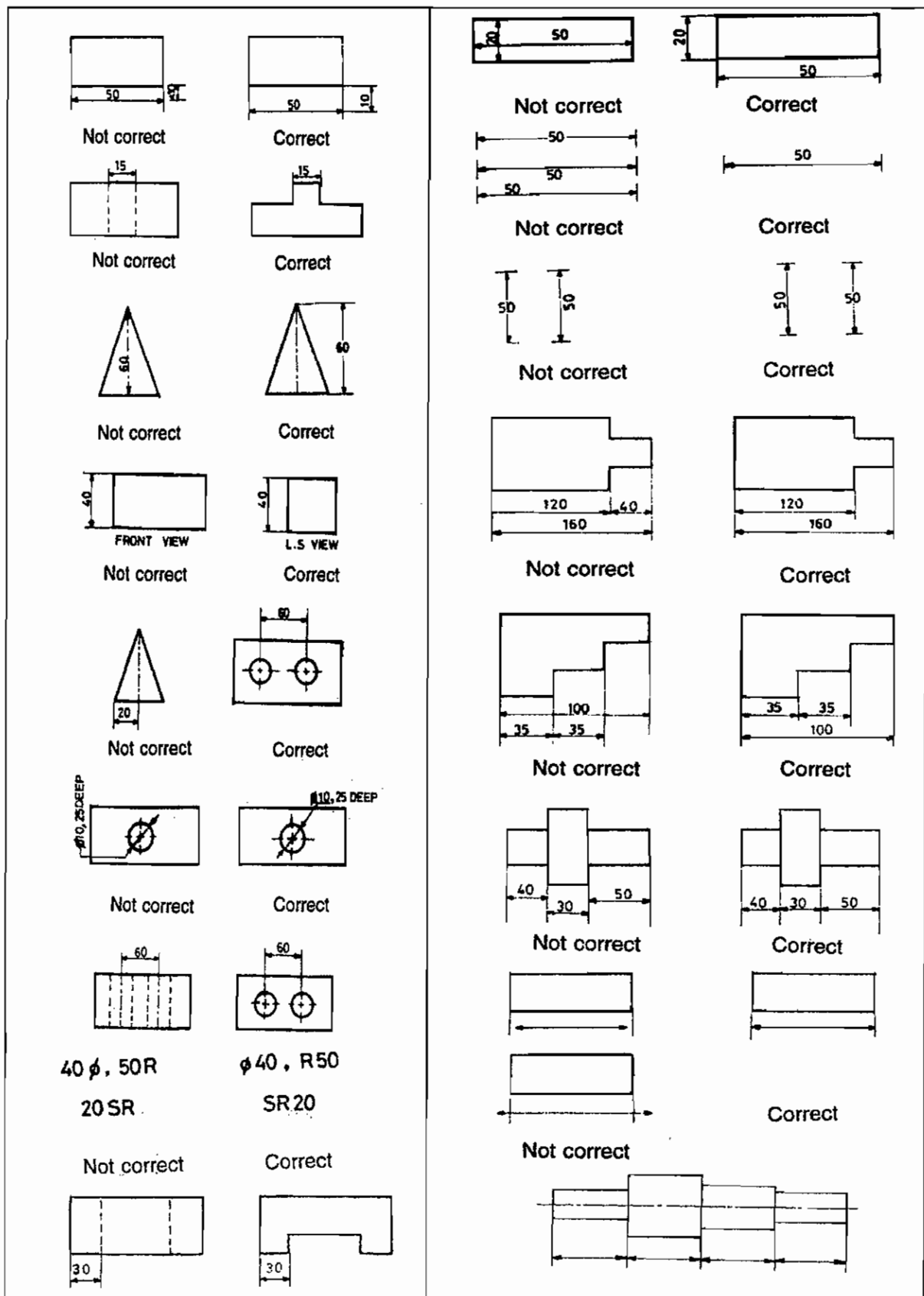

Fig. 1.2.12. Selection of Dimensioning

### 1.2.5 METHOD OF DIMENSIONING

Dimensioning the Engineering drawing can be indicated as per the recommendation of IS : 116699 – 1986.

#### Method 1 (Aligned System)

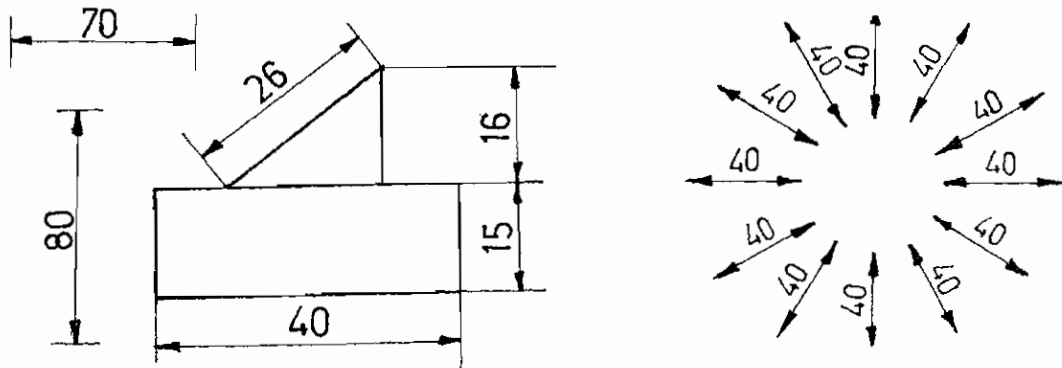

Fig. 1.2.13 Method of dimensioning.

Dimensioning lines should be continuous when dimensioning is followed in this method.

When writing the numerals in dimensioning it should be above, below and parallel to dimension line and should not touch it.

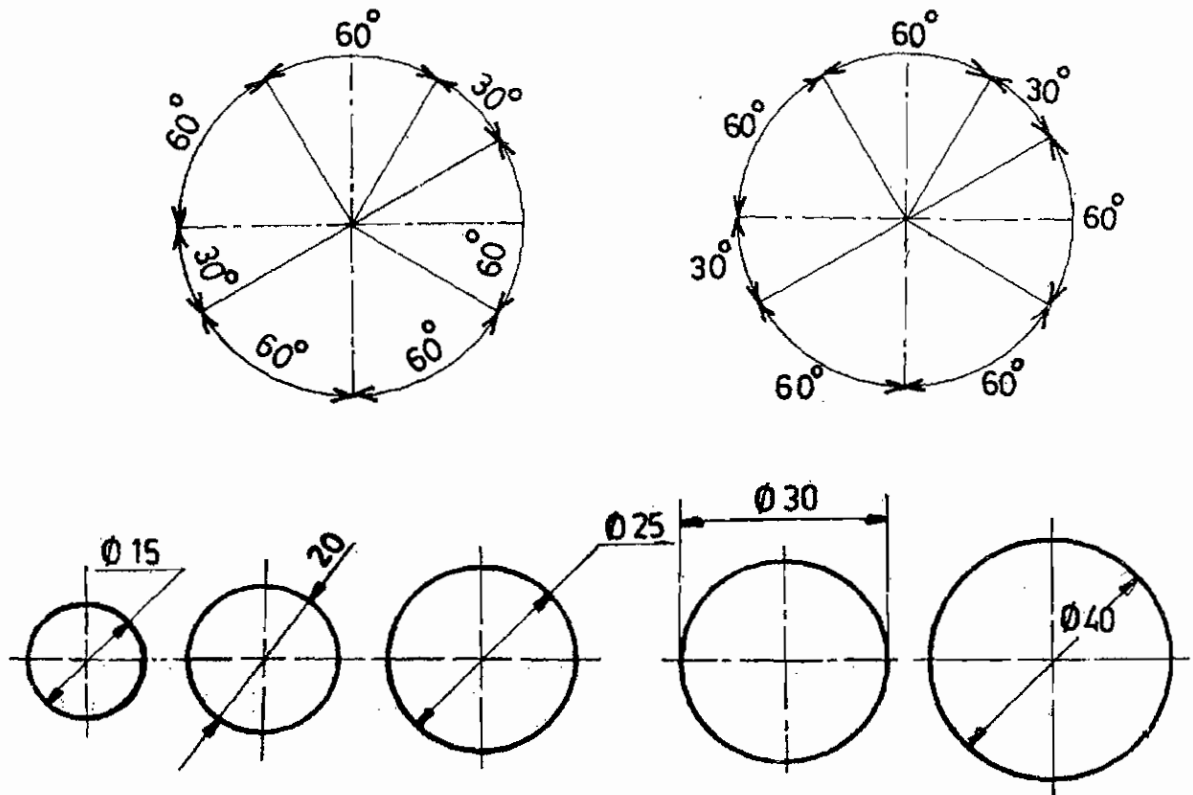

Fig. 1.2.14. Dimension of circles



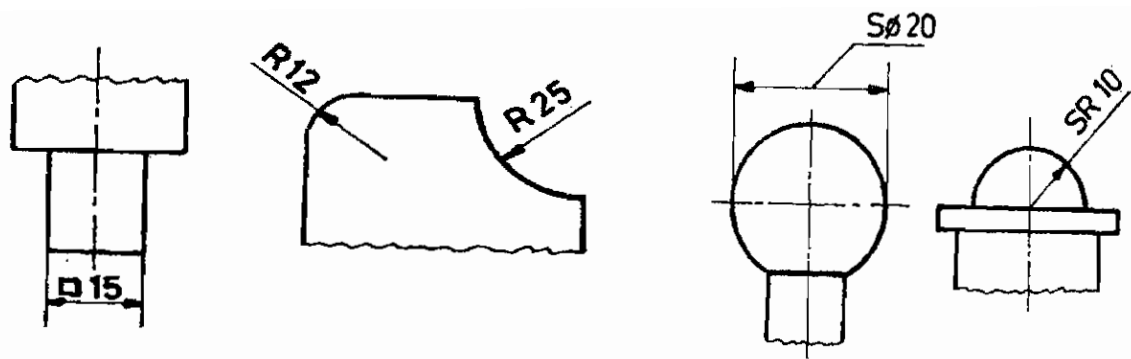

Fig. 1.2.15. Dimensioning of circular Arc

When indicating the measurements in such a way it should be read from the base of drawing or indicated at the right side of drawing. Inclined dimension line and angles are indicated as shown in sketch.

This dimensioning method is called Aligned system.

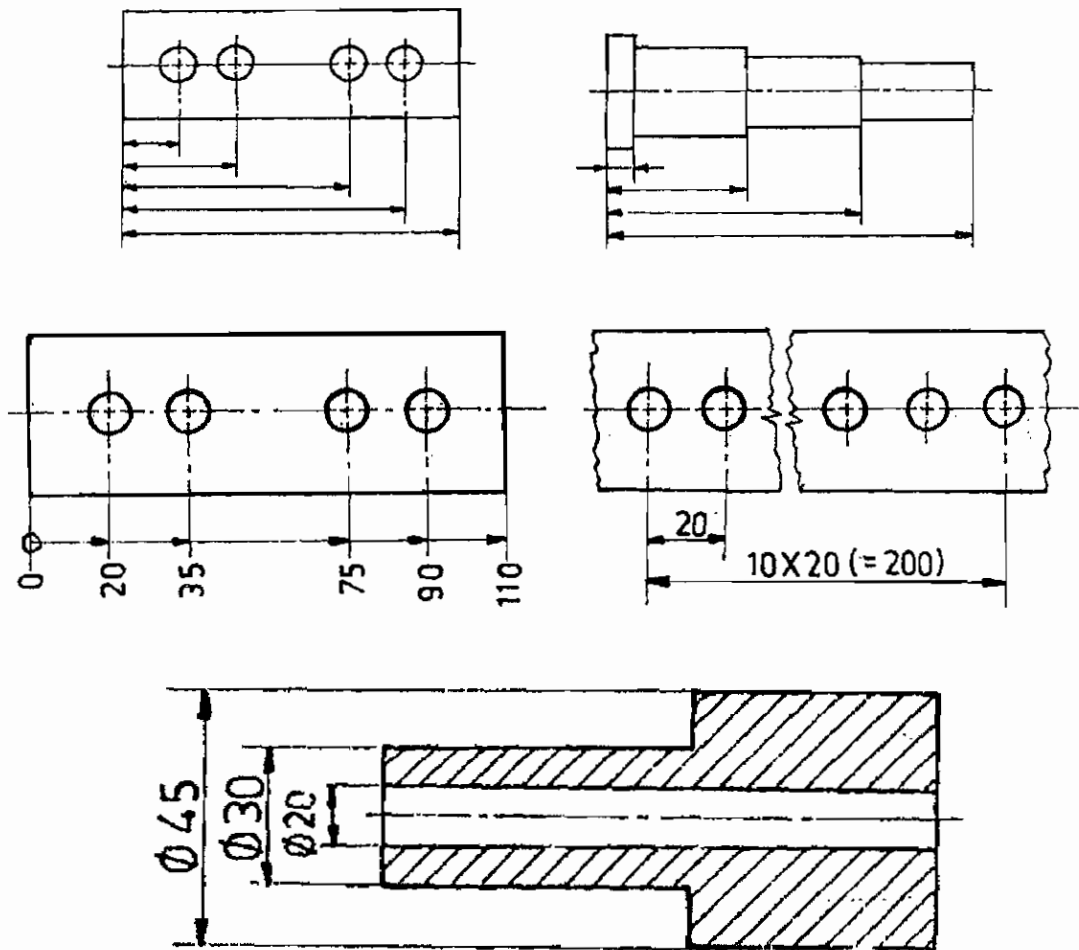
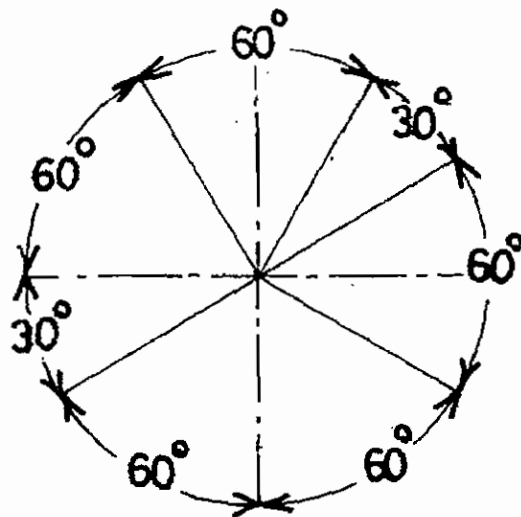
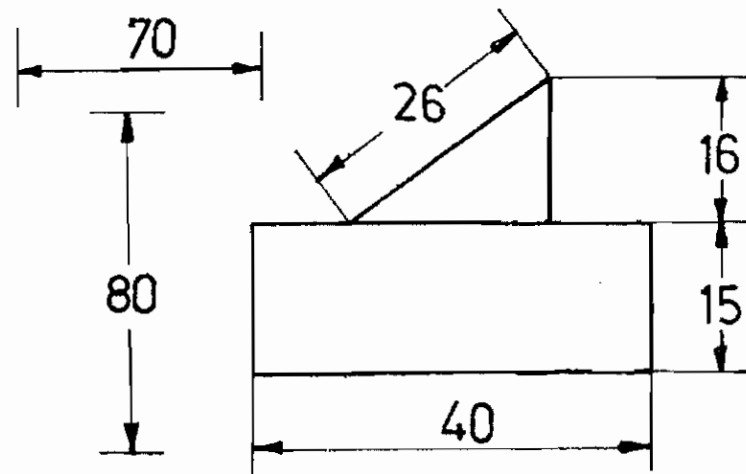

Fig. 1.2.16. Dimensioning the circle with line

### Method - 2 (Unidirectional System)



**Fig. 1.2.17. Dimensioning**

When dimensioning in this method measurements in dimension line are indicated horizontally as per first method. Non horizontal dimension lines are drawn at its centre with small gap. It should not be continuous. While indicating the measurements all measurements should be written perpendicular to horizontal, it should be read from the base of Angular measurements which are indicated as shown in figure previously this dimensioning method is called unidirectional system. When indicating the measurements in Engineering drawing any one of the above method should be followed.

## QUESTIONS

### Part A

#### I. Choose the best answer

- 1) The line used to show the outer edge of an object.  
a) Object line   b) Hidden Line   c) Cutting-plane line,   d) Dimension line.
- 2) To indicate the measurement of an object the line used  
a) Extension line   b) Dimension line   c) Centre line   d) Hidden line
- 3) Angle of slanting letter.  
a)  $15^\circ$    b)  $30^\circ$    c)  $75^\circ$    d)  $45^\circ$
- 4) Angle between the arrow mark may be from \_\_\_\_\_ to \_\_\_\_\_.  
a)  $60^\circ - 90^\circ$    b)  $15^\circ - 90^\circ$    c)  $15^\circ - 30^\circ$    d)  $30^\circ - 45^\circ$
- 5) Section line are drawn at equal interval of \_\_\_\_\_ angle.  
a)  $45^\circ$    b)  $60^\circ$    c)  $30^\circ$    d)  $15^\circ$
- 6) \_\_\_\_\_ line used to cut an object is called cutting plane line.  
a) Imaginary   b) straight   c) vertical   d) All the above

### Part B

#### II. Answer in one (or) two words

- 1) Grade of Pencil used to write dimension line.
- 2) What are the symbols represented to denote diameter, radius in dimensioning.
- 3) What are the pencils used to indicate numerals and letters in drawing.
- 4) In how many ways dimensioning are indicated.
- 5) As far as possible where the measurements are indicated.

### Part C

#### III. Answer in one (or) two sentences

- 1) What is meant by extension line?
- 2) What is meant by dimension line?
- 3) What is meant by centre line?
- 4) What is meant by cutting plane line.
- 5) What is the angle of Inclined letter.
- 6) What is meant by dimensioning.

## **Part D**

### **IV. Answer Shortly**

- 1) Write the types of lines and describe the leader line and arrow mark.
- 2) What is the difference between the short break line or long break line.
- 3) What are the basic points of dimensioning.
- 4) Draw and show the dimensioning as per method I dimensioning.
- 5) Show how small arcs are indicated by dimensioning.

## **Part E**

### **V. Answer in detail**

- 1) Write the types of lines and define.
- 2) What are the principles followed in dimensioning.
- 3) Draw and explain the methods of dimensioning.

## UNIT II

### BUILDING MATERIALS

#### 2.1. STONES

##### 2.1.1. INTRODUCTION

In the early days man was living in caves and huts with broken trees and leaves. Then stones were used in building for better huts. In construction of temples, stones were used in foundation, walls, roof slabs and pavements. They are generally classified as below:

##### 2.1.2. CLASSIFICATION OF ROCKS

###### 1. Geological Classification of Rocks

Stones are derived from the rocks forming the crust of earth's surface. Rocks are classified in a variety of ways. Geologically it can be classified as,

- a. Igneous rocks
- b. Sedimentary rocks
- c. Metamorphic rocks.

###### a. Igneous rocks

They are volcanic origin. It is the result of consolidation of molten earth in combination with other substances under the action of cool air above or below the surface of the earth.

eg. granite, basalt, trap.

###### b. Sedimentary rocks

Under the action of wind, rain, frost and certain chemicals contained in air or dissolved in water, the rocks get disintegrated and broken up into pieces. It is migrated from one place to another place and formed by deposition. So it is called as sedimentary rocks.

eg. sandstones, limestones.

###### c. Metamorphic rocks

Those are originally formed in either of the above two processes. But subsequently changed or metamorphosed in colour, structure and texture under sufficient heat or pressure or both.

Eg. Dolomite, marble, salt

###### 2. Physical Classification of Rocks

It is based on general structure of stone. It is the manner in which its mass is arranged. There are three main divisions. They are,

- a. Unstratified
- b. Stratified
- c. Foliated.

**a. Unstratified**

These are of igneous origin and they have become solid mass by the process of cooling.  
eg. granite.

**b. Stratified**

Mostly the stratified structure is due to a series of parallel layers of sedimentary rocks.  
e.g. slates

**c. Foliated**

It is a parallel rearrangement of minerals showing tendency to split in definite direction.  
eg. gneisses

**3. Chemical Classification of Rocks**

This is made on the basis of their chief constituents.

**a. Silicious rocks**

Silica (sand) quartz, flint are the chief materials.  
eg. granite, trap, sandstone.

**b. Calcareous rocks**

In this, calcium carbonate predominates.  
eg. lime stone, kankar, dolomite, marble.

**c. Argillaceous rocks**

In this, calcium argile or clay form the base.  
e.g. slate, laterite

**2.1.3. USES OF STONES**

Stone are largely used in many permanent engineering works on account of the durability and the least expensive upkeep of such structures. The principal uses of stone in construction are :

1. Materials for foundation and walling of buildings, dams, bridges, etc.
2. Materials for road construction and concrete making in the form of broken or crushed stones.
3. Thin slabs for pavings.

4. Ornamental works.
5. Roofing tiles in the form of slates.
6. Lime stone for manufacture of cement.
7. Bindage for flooring and covering road surface.

#### 2.1.4. REQUIREMENTS OF GOOD BUILDING STONE

Following are the requirements of a good building stone:

- 1) **Crushing strength** : For a good structural stone, the crushing strength should be greater than  $100 \text{ N/mm}^2$ .
- 2) **Appearance** : The stones which are to be used for face work should be decent in appearance and they should be capable of preserving their colour uniformly for a long time. The colour of the stones for face work should be chosen by keeping in mind the general get up of the surrounding area.
- 3) **Durability** : A good building stone should be durable. The various factors contributing to durability of a stone are its chemical composition, texture, resistance to atmospheric and other influences, location in structure, etc.

The important atmospheric agencies which affect the durability of a stone:

Alternate conditions of heat and cold due to differences in temperature:

- 4) **Facility of dressing** : Stones should be such that they can be easily carved, moulded out and dressed. It is an important consideration from the economic point of view.
- 5) **Fracture**: For a good building stone, its fracture should be sharp, even, bright and clear with grains, well cemented together. A dull, chalky and earthy fracture of a stone indicates signs of early future decay.
- 6) **Hardness**: The coefficient-of-hardness, as worked out in hardness test, should be greater than 17 for a stone to be used in road work. If it is between 14 and 17, the stone-is said to be of medium hardness.
- 7) **Attrition** : In attrition test, if wear is more than 3 per cent, the stone is not satisfactory. If it is equal to 3 per cent, the stone is just tolerable.
- 8) **Fire Resistance** : The minerals composing stone should be such that shape of stone is preserved when a fire occurs.
- 9) **Seasoning** : The stones should be well seasoned before putting into use. The stones obtained fresh from a quarry, contain some moisture which is known as the quarry sap. The presence of this moisture makes the stone soft. Hence the stones quarried freshly are easy to work.
- 10) **Specific gravity**: For a good building stone, its specific gravity should be greater than 2.7 or so.

- 11) **Texture:** A good building stone should have compact fine crystalline structure free from, cavities, cracks or patches of soft or loose material. The stones with such texture are strong and durable.
- 12) **Toughness:** A good building stone if the value of toughness.
- 13) **Water absorption:** All the stones are more or less porous, but for a good stone, percentage absorption by weight after 24 hours should not exceed 0.60. The porous stones seriously affect the durability of stones. The rain water as it descends through the atmosphere absorbs some acidic gases forming light acids.
- 14) **Weathering :** A good building stone should have good toughness property.

### 2.1.5. CHARACTERISTICS OF STONES

#### 1. Granite

Granite is an igneous rock, hard, heavy and impervious stone with a molten appearance. It is available in wide range of uniform colours like grey, green, brown, pink and red. The texture of granite varies with its qualities. The selection of the quality of granite stone for a particular job depends upon the size of the crystal grains weathering. Fine grained granite can be easily dressed and worked and as such it is usually recommended for ornamental works and for exterior facing of buildings. Medium or coarse - grained granite, on account of its hardness, strength, silent weather - resisting combined with good appearance is considered to be the best stone for the construction of bridges, marine works and other exposed massive structures. Highly grained granites are most suitable for use in the form of crushed stones, such as road metal, railway ballast and aggregate for concrete.

Most valuable granites are usually either grey or red. Since stones of these colours are indicated the presence of more weather resistant minerals present in the composition of the stones, Granites can be easily dressed, ground and polished.

Granite weigh from 26000 to 27000 N/cu.m and their compression strength range from 70 to 130 N/mm<sup>2</sup> and above. Since the mineral of which the granites are usually have composed different co-efficient of thermal expansions. They do not resist well.

It is available in states of Kashmir, Tamilnadu, Punjab, Rajasthan, UP, M.P., Karnataka, Maharashtra, Assam, Bihar, Kerala and Gujarat

#### 2. Sand Stone

It consists of quartz and other minerals, easy to work and dress and available in different colours. Its specific gravity varies from 2.65 to 2.95 and compressive strength is 64 N/mm<sup>2</sup>. It is used for steps facing work, columns, flooring, walls, road metal, ornamental carving etc., sand stones are chiefly found in Andhrapradesh, M.P., U.P., Gujarath, Punjab, Rajasthan, Himachal Pradesh, Maharashtra, Bihar, and Andaman Island etc.

#### 3. Limestone

Granular lime stone consists of pure calcium carbonate. Its particles are quite large and is white, light grey in colour. This stone is soft, light and absorbent.



All types of limestone have specific gravity varying from 2.00 to 2.75 and compressive strength of 55 N/mm<sup>2</sup>. Limestones are used for floors, steps, walls, road, metal manufacture of iron in blast furnaces etc.

It is available in Maharashtra, Rajasthan, Punjab, Gujarat, Bihar, Himachal Pradesh, Madhya Pradesh and Uttar Pradesh.

#### **4. Marble**

It is chiefly used for interior decorative works, mostly in the form of veneers. It is commonly used for wall lining, columns, plasters, tableslabs, hearths, tiled floors, steps of staircase and electrical switchboards etc. Its Specific gravity is 2.65 and its compressive strength 72 N/mm<sup>2</sup>.

It is available in the state of Rajasthan, Maharashtra, Gujarat, Andhra, Karnataka, M.P., and U.P.

#### **Selection of Stones for different uses**

Stones are used in the following types.

1. Structural construction like foundation, walls, columns, lintels, arches, floors, etc.
2. Face-work for appearance.
3. Pavings of floors in various buildings.
4. Base material for concrete, roads, ballast for railways etc.

Based on required quality of stones for various uses, types of stones are selected.

#### **2.1.6. ARTIFICIAL STONES**

Crushed pieces of stones of size less than 6 mm are used to make artificial stones by mixing cement and sand,

#### **Types of Artificial Stones**

##### **1. Cement Concrete**

It is made up of cement, aggregate and water.

##### **2. Mosaic Tiles**

It is made up of concrete with marble chips.

##### **3. Terrazzo**

It is made of white marble with cement mortar and colouring agents.

##### **4. Victoria Stones**

It is made from granite pieces and immersed in soda silicate solution for 8 weeks.

##### **5. Ransom Stones**

It is made by mixing sand with soda silicate.

## QUESTIONS

### PART - A

#### I. CHOOSE THE BEST ANSWER

- 1) Rocks formed by cooling of magma to the earth's surface.  
a) Calcareous Rock      b) sedimentary rock      c) Igneous rock      d) Metamorphic rock
- 2) Metamorphic Rocks are  
a) Granite                      b) Marble                      c) Silica                      d) stone
- 3) Content of calcium carbonate in Calcareous rock  
a) High                      b) Low                      c) Medium                      d) None of these
- 4) Generally Granite is  
a) stone                      b) Marble                      c) Latrite                      d) slate
- 5) Stones manufactured by mixing soda silicate and sand  
a) Terrazo stone              b) Mosaic stone              c) Randan stone              d) Victoria stone
- 6) Effect of porosity in stone  
a) Air enters                      b) water absorption      c) Low weight                      d) Easily breakable
- 7) Relative density of stone  
a) 0.7                      b) 1.7                      c) 2.7                      d) 3.7

### PART - B

#### II) ANSWER IN ONE (OR) TWO WORDS:

- 1) What is the name of magma below the earth.
- 2) Given an example for sedimentary rock.
- 3) Write the Hardness value of stone used for roads.
- 4) What is the classification of stone.
- 5) Write the uses of sand stone.
- 6) Write the two places of availability of Lime stone.
- 7) Write any one variety of rock classified by its physical properties.

### **PART-C**

#### **III) ANSWER IN ONE (OR) TWO SENTENCES:**

- 1) Define stone.
- 2) Write the types of Geographical classification of rocks.
- 3) Write types of rocks classified by its chemical property.
- 4) Write the properties of Granite.
- 5) Write about Igneous rocks.
- 6) What is the difference between stratified rock and non stratified rock.
- 7) In which state marble stones are available.
- 8) What are artificial stone?

### **PART-D**

#### **IV) ANSWER SHORTLY:**

- 1) Write the classification of rock based on geographical structure.
- 2) What are the uses of stones.
- 3) Define classification of rock on the basis of its Physical structure.
- 4) Define the stones manufactured on the basis of Artificial method.

### **PART-E**

#### **V) ANSWER IN DETAIL:**

- 1) What are the required properties of a good stone.
- 2) Define the types of stones and its properties.

## **2.2. BRICKS**

### **2.2.1 INTRODUCTION**

Brick is an old building material since a very long time. Brick is used to construct the building because of its good bearing capacity, long life, strength. Bricks are made up of blending a good clay and preparing a rectangular shape of uniform size and they are dried and burned. As bricks are in uniform size they can be beautifully laid in masonry work. It can also be carried to top of the building due to its low weight.

### **2.2.2 DEFINITION**

Bricks are obtained by moulding clay in rectangular blocks, then by drying and burning them. In place where stones are not easily available, bricks are used in construction. These are preferred because of its durability, strength, reliability, low cost etc.

### **2.2.3. SIZE AND WEIGHT OF BRICKS**

The bricks are prepared in various sizes. The custom in the locality is the governing factor for deciding the size of a brick, such bricks which are not standardised are known as the traditional bricks.

BIS has recommended the bricks of uniform size. Such bricks are known as the modular bricks and the actual size of a modular brick is 190 mm x 90 mm x 90 mm. With mortar thickness, size of such a brick becomes 200 mm x 100 mm x 100 mm and it is known as the nominal size of the modular brick.

It is found that the weight of  $1\text{m}^3$  of brick earth is about 1800 kg. Hence the average weight of a brick will be about 3.00 to 3.50 kg.

### **2.2.4. Constituents of Brick Earth**

#### **1. Alumina**

It is the chief constituent of every kind of clay. A good brick earth should contain about 20 to 30 percent of alumina. This constituent imparts plasticity to earth so that it can be moulded. If Alumina is present in excess, raw bricks shrink and warp during drying and burning.

#### **2. Silica**

It exists in clay either as free or combined. As free sand, it is mechanically mixed with clay and in combined form, it exists in chemical composition with alumina. A good brick earth should contain about 50 to 60 percent of silica. Presence of this constituent prevents the events of cracking, shrinking and warping of raw bricks. It thus imparts uniform shape to the bricks. Durability of bricks depends on the proper proportion of silica in brick earth. Excess of silica destroys the cohesion between particles and bricks become brittle.

#### **3. Lime**

A small quantity of lime is desirable in good brick earth. It should be present in a finely powdered state and not in lump form, Lime prevents shrinkage of raw bricks. Sand alone is infusible, but it slightly fuses at kiln temperature in presence of lime. Such fused sand works as a hard cementing material for brick particles. Excess of lime causes the brick to melt and hence its shape is lost.

Lump of lime are converted into quick lime after burning and thus quick lime slakes and expands in presence of moisture. Such an action results in splitting of bricks into pieces.

#### 4. Oxide of Iron

A small quantity of oxide of iron is desirable in good brick earth. It helps as lime to fuse sand. It also imparts red colour to brick. Excess of iron makes the brick dark blue.

#### 5. Magnesia

A small quantity of magnesia in brick earth imparts yellow tint to brick and decrease shrinkage. But excess of magnesia leads to the decay of bricks.

### 2.2.5. Manufacture of Bricks

In the process of manufacturing bricks, the following four distinct operations are involved:

- 1) Preparation of clay
- 2) Moulding
- 3) Drying
- 4) Burning.

### 2.2.6. Preparation of Clay

Procedure in the preparation of clay are as follows.

- a. Unsoiling
  - b. Digging
  - c. Cleaning
  - d. Weathering
  - e. Blending
  - f. Tempering.
- i) **Unsoiling:** The top layer of soil, about in depth, is taken out and thrown away. The clay in top soil is full of impurities and hence it is to be rejected for the purpose of preparing bricks.
  - ii) **Digging:** The clay is then dug out from the ground. It is spread on the levelled ground, just a little deeper than the general level of ground. The height of heaps of clay is about 60 cm.
  - iii) **Cleaning:** The clay, as obtained in the process of digging, should be cleaned of stones, pebbles, vegetable matter, etc. If these particles are in excess, the clay is to be washed and screened.
  - iv) **Weathering:** The clay is then exposed to atmosphere for softening or mellowing. The period of exposure varies from few weeks to full season.
  - v) **Blending:** The clay is made loose and any ingredient to be added to it, is spread out at its top. The blending indicates intimate or harmonious mixing.

- vi) **Tempering:** In the process of tempering; the clay is brought to a proper degree of hardness and it is made fit for the next operation of moulding. The water in required quantity is added to clay and the whole mass is kneaded or pressed under the feet of men or cattle. The tempering should be done exhaustively to obtain homogeneous mass of clay of uniform character.

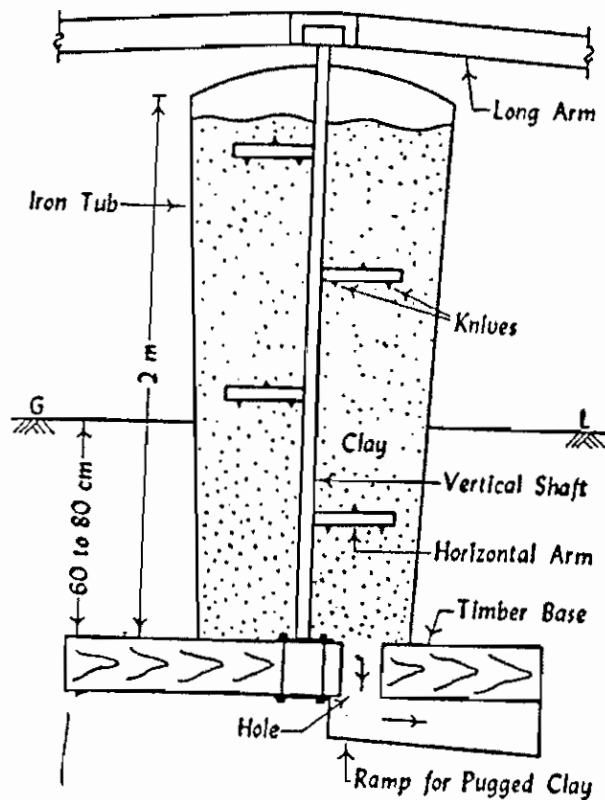

Fig. 2.2.1. Pug mill

For manufacturing good bricks on a large scale, the tempering is usually done in a pug mill: A typical pug mill capable of tempering sufficient earth for a daily output of about 15000 to 20000 bricks. The process of grinding clay with water and making it plastic is known as the pugging.

**2.2.7. Moulding:** The clay which is prepared as above is then sent for the next operation of moulding. Following are the two ways of moulding:

1. Hand moulding
2. Machine moulding.

**1. Hand moulding:** In hand moulding, the bricks are moulded by hand i.e. manually. It is adopted where manpower is cheap and is readily available for the manufacturing process of bricks on a small scale. The moulds are rectangular boxes which are open at top and bottom. They may be of wood or steel.

A typical wooden mould should be prepared from well seasoned wood. The longer sides are kept slightly projecting to serve as handles. The strips of brass or steel are sometimes fixed on the wooden moulds to make them more durable.

A typical steel mould is prepared from the combination of steel plates and channels. It may even be prepared from steel angles and plates. The thickness of steel mould is generally 6 mm. They are used for manufacturing bricks on a large scale. The steel moulds are more durable than wooden moulds and they turn out bricks of uniform size.

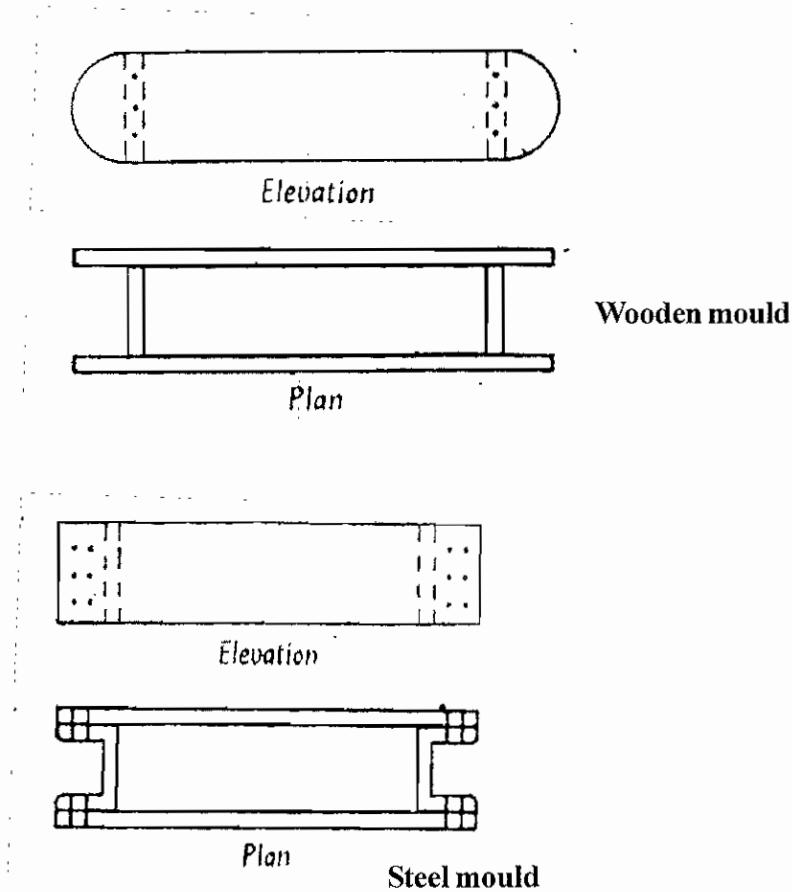

**Fig. 2.2.2. Hand Moulding**

The bricks shrink during drying and burning. Hence the moulds are to be made larger than the size of fully burnt bricks. The moulds are therefore made longer by about 8 to 12 per cent in all directions. The exact percentage of increase in dimensions of mould is determined by actual experiment on clay to be used for preparing bricks.

The bricks prepared by hand moulding are of two types:

- a) Ground-moulded bricks
- b) Table-moulded bricks.

**a) Ground-moulded bricks:** The ground is first made level and fine sand is sprinkled over it. The mould is dipped in a water and placed over the ground. The lump of tempered clay is taken and it is dashed in the mould. The clay is pressed or forced in the mould in such a way to fills all the corners of mould. The extra or surplus clay is removed either by wooden strike or metal strike or frame with wire. A strike is a piece of wood or metal with a sharp edge. It is to be dipped in water every time.

The mould is then lifted up and raw brick is left on the ground. The mould is dipped in water and it is placed just near the previous brick to prepare another brick. The process is repeated till the ground is covered with raw bricks.

The lower faces of ground moulded bricks are rough and it is not possible to place frog on such bricks. A frog is a mark of depth about 10 mm to 20 mm which is placed on raw brick during moulding.

The ground-moulded bricks of better quality and with frogs on their surface are made by using a pair of pallet boards and a wooden block.

**b) Table-moulded bricks:** The process of moulding these bricks is just similar as above. But in this case, the moulder stands near a table of size about 2 m x 1 m. The clay, mould, water pots, stock board, strikes and pallet boards are placed on this table. The bricks are moulded on the table and sent for the further process of drying. However the efficiency of moulder decreases gradually because of standing at the same place for long duration. The cost of brick moulding also increases when table moulding is adopted.

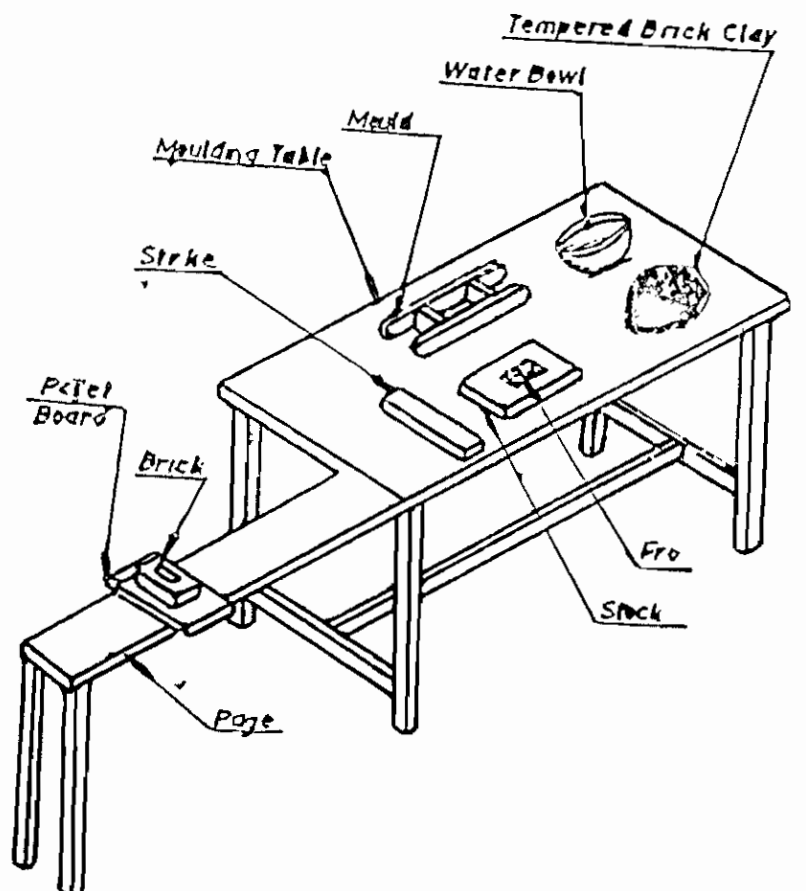

**Fig. 2.2.3. Table Moulded Bricks**

**2) Machine moulding:** The moulding may also be achieved by machines. It proves to be economical when bricks in huge quantity are to be manufactured at the same spot in a short time. It is also helpful for moulding hard and strong clay. These machines are broadly classified in two categories:



- a) Plastic clay machines
  - b) Dry clay machines.
- a) Plastic clay machines: Such machines contain a rectangular opening of size equal to length and width of a brick. The pugged clay is placed in the machine and as it comes out through the opening, it is cut into strips by wires fixed in frames. The arrangement is made in such a way that strips of thickness equal to that of the brick are obtained. As the bricks are cut by wire, they are also known as the wire cut bricks.
  - b) Dry clay machines: In these machines, the strong clay is first converted into powder form. A small quantity of water is then added to form a stiff plastic paste. Such paste is placed in mould and pressed by machine to form hard and well shaped bricks. These bricks are known as the pressed bricks and they do not practically require drying. They can be sent directly for the process of burning.

The wire cut and pressed bricks have regular shape, sharp edges and corners. They have smooth external surfaces. They are heavier and stronger than ordinary hand-moulded bricks. They carry distinct frogs and exhibit uniform dense texture.

### 2.2.8. Drying

The damp bricks, if burnt, are likely to be cracked and distorted. Hence the moulded bricks are dried before they are taken for the next operation of burning. For drying, the bricks are laid longitudinally in stacks of width equal to two bricks. A stack consists of eight or ten tiers. The bricks are laid along and across the stock in alternate layers. All bricks are placed on edge. The bricks should be allowed to dry till they become leather hard or bone-dry with moisture content of about 2 per cent or so.

**i) Artificial drying:** The bricks are generally dried by natural process. But when bricks are to be rapidly dried on large scale/the artificial drying may be adopted. In such a case, the moulded bricks are allowed to pass through special dryers which are in the form of tunnels or hot channels or floors.

The temperature is usually less than 120°C and the process of drying of bricks takes about 1 to 3 days depending upon the temperature maintained in the dryer, quality of clay product, etc.

Usually it takes about 10 days for bricks to become dry.

**2.2.9. Burning:** This is a very important operation in the manufacture of bricks. It imparts hardness and strength to the bricks and makes them dense and durable. The bricks should be burnt properly. If bricks are overburnt, they will be brittle and hence break easily. If they are underburnt, they will be soft and cannot carry loads.

When the temperature of dull red heat, about 650°C, is attained, the organic matter contained in the brick is oxidized and also the water of crystallization is driven away.

When the temperature of about 1100°C is reached, bind themselves together resulting in the increase of strength and density of bricks. Further heating is not desirable and if the temperature is raised beyond 1100°C, a great amount of fusible glassy mass is formed and the bricks are said to be vitrified.

## Clamps

They are used in brick-making on a large scale and continuous supply of bricks has to be kept up.

A rectangular clamp, which is very commonly used in South India is shown in fig. 1.4. Rectangular clamps give better results than circular clamps. At first, the site for the clamp is carefully levelled and consolidated. A trench is cut round the clamp to catch any rain water which may otherwise get into flues.

The two lower courses of the flue walls called benches are laid with burnt bricks. The benches between the flues are then built up with raw bricks to about 0.7 metres in height. The upper two courses are corbelled out to meet over the flues after filling the flues with fire wood. Over this five layers of raw bricks on edge are stacked. So that the fire from the bottom flues may reach the fuel in the upper set of flues. In this way four or five sets of flues one over the other are constructed and filled with wood fuel. The top is covered with two courses of bricks. The wood fuel in the bottom flues is then lighted and the draught afterwards regulated by opening or closing the flues. A slow fire is kept up until all the steam as indicated by the white smoke, turning to black smoke, has disappeared from the top of the clamp. The top is then covered with a layer of earth and the firing allowed to go on rapidly for about 3 days or until the seating of the clamp is within 30 cms of the top of the casing. Each clamp will burn from 20,000 to 3,00,000 bricks at a time and takes about 3 months to burn and cool.

## Kilns

A kiln is a large oven which is used to burn bricks. The kilns which are used in the manufacture of bricks are of the following two types.

1. Intermittent kilns
2. Continuous kilns

These kilns are intermittent in operation which means that they are loaded, fired, cooled and unloaded.

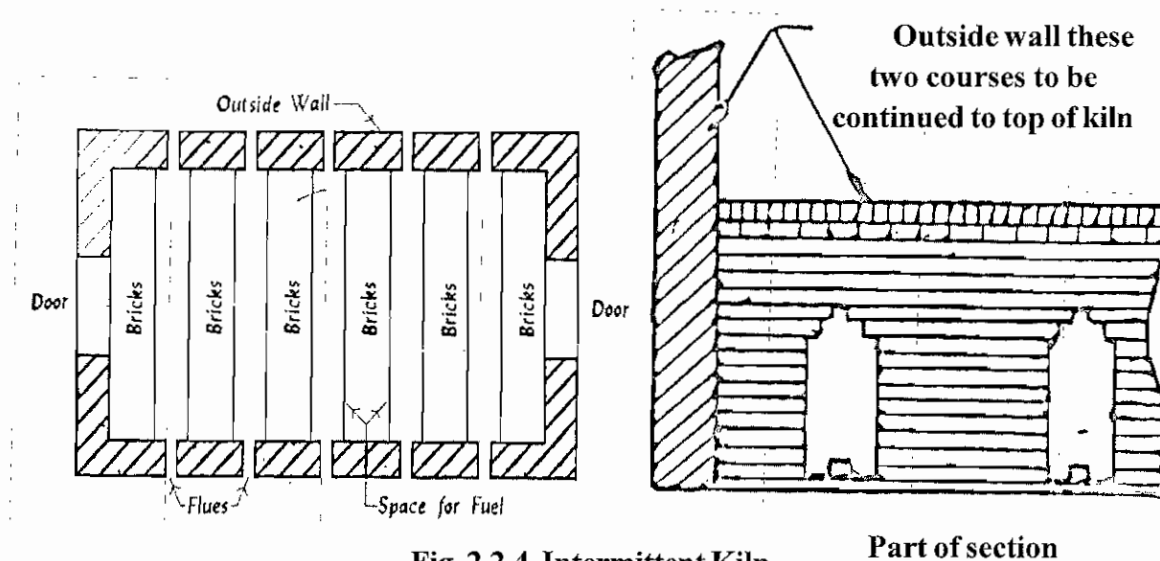

Fig. 2.2.4. Intermittent Kiln

Part of section

Continuous operation of the above process carried out at a stretch in this kiln hence it is called continuous kiln.

There are various types of the continuous kilns. Following three varieties of kilns are

- a. Bull's trench kiln
- b. Hoffman's kiln
- c. Tunnel kiln

### Hoffman's Kiln

This kiln is constructed overground and hence it is sometimes known as flame kiln. Its shape is circular in plan and it is divided into a number of compartments or chambers. The fig. shows the plan and section of Hoffman's kiln with 12 chambers. Each chamber is provided with the following :

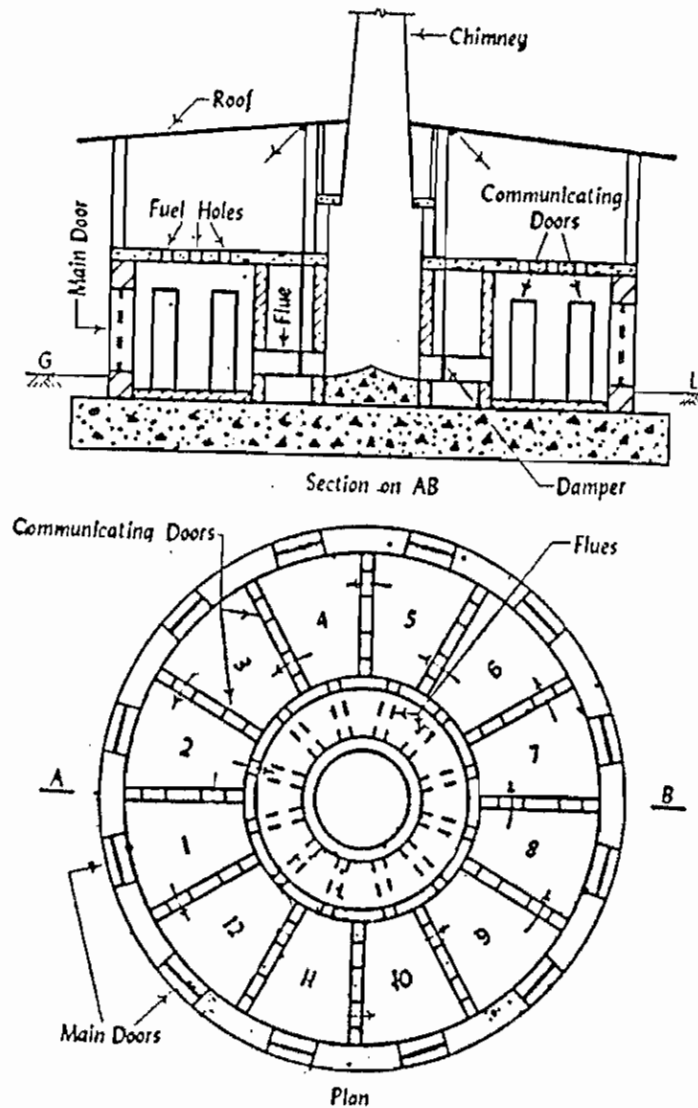

Fig. 2.2.5. Hoffman's Kiln

1. A main door for loading and unloading of bricks.
2. Communicating doors which would act as flues in open condition.
3. A radial flue connected with central chimney and
4. Fuel holes with covers to drop fuel, which may be in the form of powdered coal.

Main doors are closed by dry bricks and covered with mud, when required. For communicating doors and radial flues, dampers provided to shut or open them. In the normal condition only radial flue is connected to chimney to establish a draught.

In this type of kiln, each chamber performs various function succession, namely, loading, drying, burning and cooling. As illustrated 12 chambers shown in the figure may be functioning as follows:

With the above arrangement, circulation of the flue gas will as shown by arrows in the figure. Cool air enters through chambers 1 and 11, 12 as their main doors are open as the raw bricks are stacked. After crossing the cooling chambers 10, 9 and 8 enters the burning section 7, 6 and 5 in a heated condition. It is then moves to chambers 4, 3 and 2 to dry and preheat the raw bricks. Damper of chamber 2 is in open condition and hence, it escapes into atmosphere through chimney.

### **2.2.9. CLASSIFICATION OF BRICKS**

Bricks are classified in to two types

1. Un burnt bricks
2. Burnt bricks

First type of brick may be burnt by sun light. (or) when burnt in kiln it may not be burnt well with this bricks only temporary structure can be constructed.

Second type of bricks are well burnt bricks so they can be used for permanent structure. The well burnt bricks are :

- |                        |                        |
|------------------------|------------------------|
| 1. First class bricks  | 3. Third class bricks  |
| 2. Second class bricks | 4. Fourth class bricks |

#### **1. First Class Bricks**

These bricks are table moulded and burnt in kilns. It should be thoroughly burnt (without being vitrified) and should have rectangular plane surfaces with parallel sides and sharp straight right-angled edges. It should have firm compact and uniform texture.

#### **2. Second Class Bricks**

These bricks are ground moulded and burnt in kilns. These bricks should be in general to meet the requirements of first class bricks except that these may be slightly chipped, distorted or may have surface cracks.

#### **3. Third Class Bricks**

These bricks are ground moulded and burnt in clamps. They are not hard and have rough surfaces with irregular distorted edges. These bricks are used in unimportant and temporary structures and in places where rainfall is less.

#### **4. Fourth Class Bricks**

These bricks are overburnt bricks with irregular shape. These are used as aggregate in foundations, floors etc. They are sometimes stronger due to over burning.

### **2.2.10. PROPERTIES OF A GOOD BRICKS**

Good bricks to be used for the construction of important structure should possess the following qualities.

1. Bricks should be table-mounted, well-burnt in kilns, copper coloured, free from cracks and with sharp and square edges.
2. Bricks should be uniform in shape and should be of standard size. (20cm x 10cm x 10cm)
3. Bricks should give clear ringing sound when struck with each other.
4. Bricks when broken should show homogeneous and compact structure free from voids.
5. Brick should not absorb water more than 20 percent by weight for first class bricks and 22 percent by weight for second class bricks, when soaked in water for a period of 24 hrs.
6. Bricks should be sufficiently hard. No impression should be left on brick surface, when, it is scratched with finger nail.
7. Bricks should not break into pieces when dropped flat on hard ground from a height of about a metre.
8. Bricks should have low thermal conductivity and they should be sound proof.
9. The bricks when soaked in water for 24 hours should not show deposits of white salts when allowed to dry in shade.
10. No brick should have the crushing strength below 55 kg / cm<sup>2</sup>.

### **2.2.11. SPECIAL TYPES OF BRICKS AND THEIR USES**

Bricks are made in a variety of shapes to suit the particular work for which they are required. The different kinds of bricks generally turned out in India are given below.

#### **1. Rectangular or Ordinary Bricks**

Ordinary bricks are rectangular in section, both longitudinal and transverse and solid throughout. Most ordinary bricks have a hollow mark in one of the larger surfaces called the frog. This is to afford a key to the mortar.

#### **2. Bull-nose Bricks**

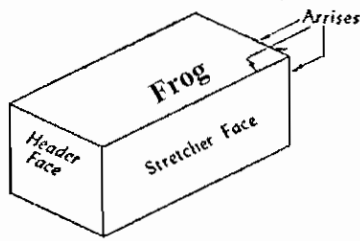

**Fig. 2.2.6. Rectangular or Ordinary Bricks**

Bull-nose brick shown in used for rounding off sharp corners. The bricks is sometimes called a cow nose. It is suitable for copings.

These are used in the construction of acute and obtuse

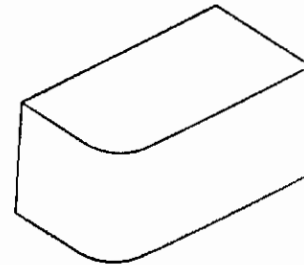

**Fig. 2.2.7. Bull-nose Bricks**

### 3. Squint Bricks

squint quoins.

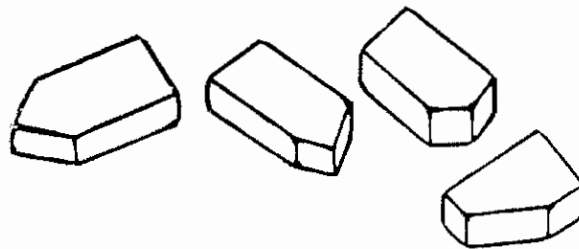

**Fig. 2.2.8. Squint Bricks**

### 4. Dog leg or Angle Bricks

This brick is also used as squint quoins particularly for cavity walls.

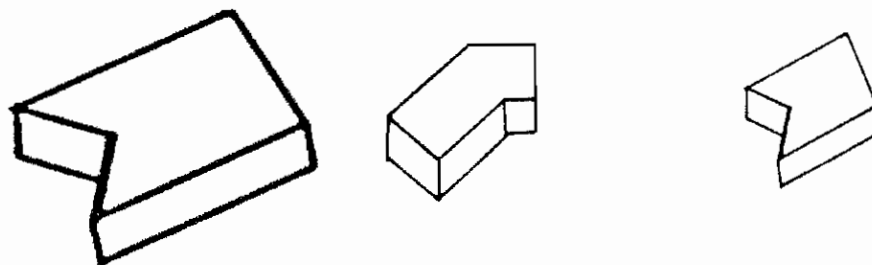

**Fig. 2.2.9. Dog leg or Angle Bricks**

### 5. Birds mouth Bricks

This bricks may be used at alternate courses of internal squint quoins.

### 6. Plinth Bricks

These bricks are used in plinths, in door and window jambs.

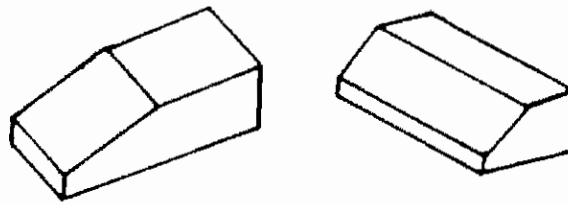

**Fig. 2.2.10. Plinth Bricks**

### **7. Coping Bricks**

These are made in different forms and are used in copings. A few standard shapes are Bull-nose bricks are used for the same purpose.

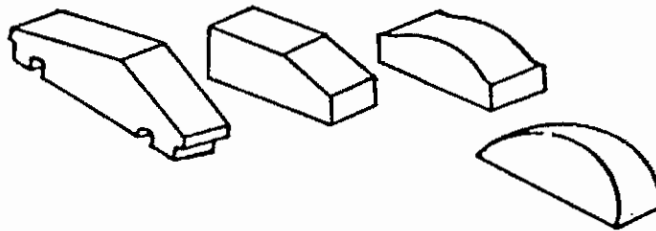

**Fig. 2.2.11. Coping Bricks**

### **8. Cornice and String Bricks**

These are made in a variety of shapes are used for forming circular or curved angles between walls or between a wall and a floor.

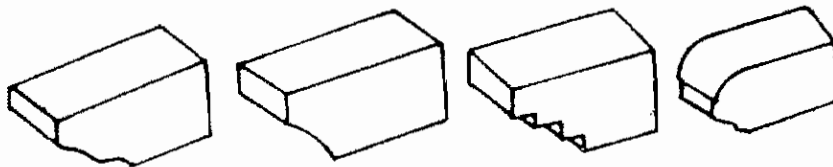

**Fig. 2.2.12. Cornice and String Bricks**

### **9. Gutter Bricks**

This brick are also called channel brick and is used the construction of gutters.



**Fig. 2.2.13. Gutter Bricks**

### 10. Tapering Bricks

This brick is also known as voussoir brick and is used for the construction of important brick arches over door and window openings.

### 11. Circular Bricks

This brick used for circular work in the construction of bay window, staircase, wells and chimneys.

### 12. Hollow Bricks

These are made in different patterns for building hollow walls. These are usually made with one or more cavities which reduce their weight about 25 percent and increase insulation against heat, sound and damp.

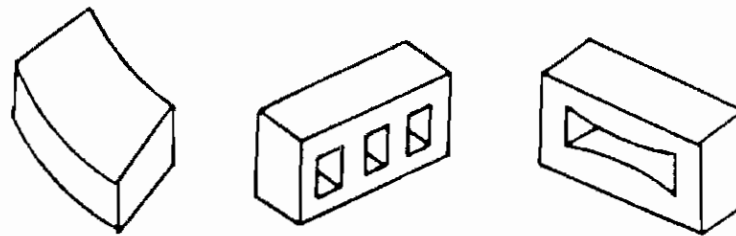

Fig. 2.2.14. Hollow Bricks

### 13. Keyed or Nicked Bricks

These have usually dovetailed grooves formed on one stretcher and one header face for the purpose of providing a good bond with either plaster or rough cast which may be applied to the brickwork.

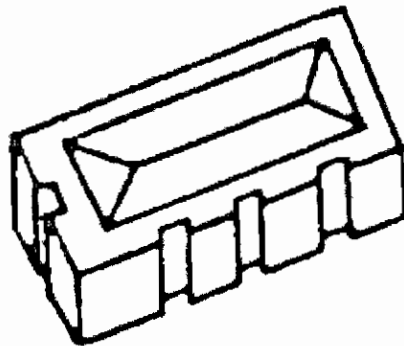

Fig. 2.2.15. Keyed or Nicked Bricks

### 14. Perforated Bricks

These have small holes (10 mm to 15 mm in diameter) formed throughout their thickness, the object of which is to reduce their weight.

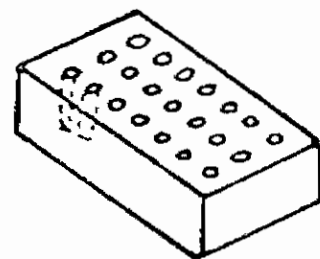

Fig. 2.2.16. Perforated Bricks



## QUESTIONS

### Part A

#### I. Choose the best answer

- 1) Brick is a
  - a) Old material
  - b) New material
  - c) Dead old material
  - d) very new material
- 2) Shape of brick is
  - a) Rectangle
  - b) squares
  - c) triangle
  - d) Irregular shape
- 3) Average weight of brick is
  - a) 3 to 3.6 kg.
  - b) 4 to 3.9 kg.,
  - c) 3 to 3.5 kg.,
  - d) 6 to 1.40 kg.,
- 4) Quantity of Alumina in a good brick earth is
  - a) 3 to 20%
  - b) 20 to 30%
  - c) 40 to 35%
  - d) 20 to 60%
- 5) Raw material used to avoid cracks in bricks
  - a) Alumina
  - b) Silica
  - c) Lime
  - d) Water
- 6) The material to be mixed to avoid shrinkage of unburnt bricks
  - a) sand
  - b) concrete
  - c) Lime
  - d) water.
- 7) The brick attains the colour when Iron Oxide mixed in correct proportion of brick earth.
  - a) Blue
  - b) Red
  - c) Black
  - d) Black Blue.
- 8) Which combination of raw material makes the collapse of brick shape.
  - a) magnesia
  - b) Iron Oxide
  - c) Lime
  - d) Silica
- 9) The kiln gives good brick
  - a) Rectangular shape
  - b) square shape
  - c) Triangular shape
  - d) circular shape
- 10) Breaking strength of brick
  - a) Less than 50 kg/cm<sup>2</sup>
  - b) Less than 55 kg/cm<sup>2</sup>
  - c) Less than 60 kg/cm<sup>2</sup>
  - d) Less than 55 kg/mm<sup>2</sup>

### PART-B

#### II) ANSWER IN ONE (OR) TWO WORDS

- 1) Write any one characteristic of a Brick.
- 2) What is the size of brick?
- 3). What is the percentage of alumina in a good brick.

- 4) At what height the brick is dropped it will not break.
- 5) When brick struck with each other what sound it gives.
- 6) What is the average weight of brick.
- 7) Write any one type of brick.

#### **PART-C**

#### **III) ANSWER IN ONE (OR) TWO SENTENCES:**

- 1) What are the size of bricks.
- 2) What are the weight of brick.
- 3) What is the raw material mixed in brick earth.
- 4) What is a brick?
- 5) Write about hand moulding of bricks.
- 6) Write 4 types of bricks.
- 7) What is burning of bricks?

#### **PART-D**

#### **IV) ANSWER SHORTLY:**

- 1) Tabulate the first quality brick and second quality brick?
- 2) Write the types of bricks according to their shape and define?
- 3) Write the raw material used to manufacture brick and define any two of them.
- 4) Define about Iron Oxide.
- 5) Define the table moulding of bricks.
- 6) What are the properties of brick.

#### **PART-E**

#### **V) ANSWER IN DETAIL:**

- 1) Write the types of bricks and define.
- 2) Draw neat sketch of a pug mill and define.
- 3) Write the types of mould and define with sketch.
- 4) Draw the neat sketch of continuous kiln and define its uses.

## UNIT III

### 3.1 CEMENT

#### INTRODUCTION

Among the essential materials in the Building construction, Cement is the primary material. It hardens after mixing in water like Hydraulic Lime. Lime and Silica are the high contents in cement.

#### 3.1.1. Type of cement

Generally,

1. Natural Cement
2. Artificial Cement

#### 1) NATURAL CEMENT

This type of cement is obtained by burning, crushing and powdering the molecular stones of natural Silica and lime. In this stone it contains 20% to 40% of clay alias Silica. It is also known as Roman Cement.

#### 2) ARTIFICIAL CEMENT

Adding Lime and clay in correct proportion and burning in high temperature. Burning this two added mixture is called Clinkar. Gypsum is added in Clinkar and grinded in powder form. This grinded powder is known as Cement. Colour of artificial cement is alike the stone in Portland of U.K. Hence it is called Portland Cement. In India in 1904, this artificial cement manufactured in Chennai.

We can classify the artificial cement as follows:

- 1) Acid resisting cement
- 2) Blast furnace slag cement
- 3) High alumina cement
- 4) Hydrophobic cement
- 5) Low heat cement
- 6) Pozzalona cement
- 7) Quick setting cement
- 8) Rapid hardening cement
- 9) Sulphate resisting cement
- 10) White cement.
- 11) Colour cement

### **1) Hydrophobic Cement**

Alcohol, Naphthal soap are used as the additional mixture for reducing the moisturizing property of cement in hydrophobic cement. The water absorbant layer is torn when water is added in this type of cement. But they does not affect the hardness of cement.

### **2. Pozzuolana Cement**

Pozzuolana denotes volcanic powder. It is available in Vesuvius of Italy. This pozzuolana is like burnt powder. Pozzuolana is prepared not only by volcanic powder also by burning a type of clay.

#### **Advantages are as follows**

- 1) When the period of time increases tensile force also increases.
- 2) It avoids the sulphate actions.
- 3) It releases less amount of heat when harden.
- 4) It is high water resistant.
- 5) Easily workable.
- 6) Cheap non expanding property
- 7) High tensile property.

It does not resist the erosion and it is disadvantage in due to the low compressive force in the initial stage.

Building construction under water, Buildings constructed for taking waste materials, Building constructed in Costal area, to make lean mix of this type of cement is used.

### **3) Quick setting cement**

This type of cement attains high hardness in minimum days. The initial setting time and final setting time of this cement is like Portland cement. This cement is manufactured by burning in high temperature. The reason for its Quick setting is more quantity of lime and grinding it to powdered form. Cost of this cement is more than Portland Cement.

Construction work becomes quick, due to its quick setting and hardening property.

Form work is removed in short time when laying the concrete. Low weight and it will not break-fast. After the construction is over, immediately loads can be lifted.

### **4. Rapid hardening cement**

The initial setting time and final setting time of cement is just like Portland cement. This cement attains high strength in minimum days. This cement is manufactured by burning with high temperature. More quantity of lime, grinding to high powder form are the reasons for its quick setting. The cost of this cement is higher than Portland cement. As this cement sets fastly and construction work is made fast.

## **5) White Cement**

White cement is manufactured by natural raw materials and non-constituents of Iron Oxide, Magnesium and Chromium. Instead of using coal. Oil is used to fire the boiler for the manufacturing process. So, White cement is obtained without smoke. This cement is used for Cement flooring excellent plastering work designing decorative arch work. Normally the cost of this cement is higher than Portland cement.

## **6. Colour Cement**

This cement is manufactured by mixing 5 to 10% of colouring pigments with ordinary cement. Strength of this cement is affected when more than 10% of pigment is added. Green colour is obtained by adding chromium oxide. Blue colour is obtained by Cobalt. Yellowish Brown, Red, Yellow colours are obtained by adding Iron Oxide in various proportions. Black colour is obtained by Magnesium Oxide. This cement is used to make artificial marble stone. External decoration, coloured cement floor.

### **3.1.2. FIELD TEST FOR CEMENT**

To know quality of cement the following tests are conducted.

- 1) Colour
- 2) Physical Properties
- 3) Presence of lumps
- 4) Strength test

#### **1) COLOUR**

Absolute colour of the cement should be in its cement colour, when cement it is seen. That is light green with ash colour.

#### **2) Physical Properties**

When Cement is touched it should be smooth. When cement is rubbed with fingers it should be smooth. If it is rough it denotes mixture of sand, when hand is inserted in the bag coolness should be felt and it should not be warm.

When small quantity of cement is put in water it should settle at the bottom and should not float.

#### **3) Presence of lumps**

Cement inside the bag should not harden due to moisture. If it is harden the cement should not be used.

#### **4) STRENGTH**

A cement cube of size 25 mm x 25 mm x 20 mm is made and it is immersed in water for 7 days cube is kept @ an interval of 250 mm and this cement cube should not brake when 34 kg weight is pressed.

Consistent cement added with water is placed on Glass Plate. This mix is immersed in water for 24 hours. The cement should be hard with the Glass Plate.

### **3.1.3. REQUIRED PROPERTIES OF PORTLAND CEMENT**

- 1) Initial setting time of cement should not be less than 30 minutes.
- 2) Final setting time should not be more than 10 hours.
- 3) After 3 days compressive force should not be less than 16 N/mm<sup>2</sup>.
- 4) After 7 days compressive force should not be more than 22 N/mm<sup>2</sup>.
- 5) After 3 days Tensile force should be 2 N/mm<sup>2</sup>.
- 6) After 7 days Tensile force should be 2.5 N/mm<sup>2</sup>.
- 7) The residue should not be more than 10%. When sieved in I.S. 90 micron Sieve.
- 8) Should not expand more than 19 mm in L-chatlier test.

Excellent Admixtures are Pozzuolona, Otter, Retarder Air entraining agents, erosion resisting agents, bonding agents, colouring agents.

## QUESTIONS

### PART-A

#### I. Choose the best answer

- 1) When heating the mixture of equal proportion of Lime and Clay the mortar we get.  
a) Gypsum                      b) Clinkar                      c) Cement                      d) None of the above.
- 2) The artificial cement manufactured in India in the year.  
a) 1904                      b) 1914                      c) 1940                      d) 1950
- 3) What is the mixture reduces the moisture of cement.  
a) Naptha Soap                      b) Aluminium                      c) Gypsum                      d) Calcium Silicate.
- 4) The type of Building structure which uses Pozzalona cement.  
a) Seashore structures                      b) Roadside structure,  
c) Public Building                      d) Residential building.
- 5) The material used in cement to attain Quick setting.  
a) Gypsum                      b) Lime                      c) Silica                      d) Residential building.
- 6) The colour we get when chromium Oxide mixed with ordinary cement.  
a) Green                      b) Yellowish Brown                      c) Yellow                      d) Light blue.
- 7) The colour we get when Magnesium-di-oxide mixed with ordinary cement.  
a) Black                      b) blue                      c) Red                      d) Green
- 8) The colour we get when cobalt mixed with ordinary cement  
a) Green                      b) Blue                      c) Yellow                      d) Red

### PART-B

#### II) Answer in one (or) two words

- 1) What is the other name of natural cement.
- 2) How the mixture of lime and clay called?
- 3) What do Pozzalono denotes.
- 4) What type of cement is used for the construction in water logged areas.
- 5) What is the colour of cement.

### **PART-C**

#### **III) Answer in one (or) two sentences**

- 1) What are the classifications of cement.
- 2) What is meant by Natural cement.
- 3) What are the classifications of Artificial cement.
- 4) What are the field test of cement.
- 5) For What type of work colour cement is used.

### **PART-D**

#### **IV) Answer Shortly**

- 1) What are the advantages of Pozzalona cement.
- 2) What is the property of Portland cement.

### **PART-E**

#### **V) Answer in detail**

- 1) What are the types of artificial cement. Explain.
- 2) What are the field test of cement. Explain.



## **3.2. MORTAR**

### **3.2.1. DEFINITION**

Mortar is a paste prepared by adding required quantity of water to a mixture of binding material like cement or lime with sand. The binding material and sand or fine aggregate are, sometimes referred as matrix and adulterant. The durability strength and quality of mortar mainly depend on the quantity and quality of the matrix. The combined effect of the two components of mortar is able to bind the bricks or stone firmly.

### **3.2.2. PROPERTIES OF MORTAR**

1. It should have good adhesion with bricks, stones etc.
2. It should be in a position to develop the desired stresses in it.
3. It should offer good resistance to the penetration of rain water.
4. It should be cheap and durable.
5. It should be in position to maintain its original appearance for sufficiently long periods.
6. It should be easily workable.
7. It should not adversely affect the building on which it is to be used.
8. It should set and harden quickly, so that speed of construction work may be maintained.
9. It should not crack in joints

### **3.2.3. TYPES OF MORTAR**

The kind of binding material for a mortar is selected by keeping in mind several factors such as expected working conditions, hardening temperature, moisture conditions, etc. According to the kind of binding material, the mortars are classified into the following categories:

1. Lime mortar
2. Surkhi mortar
3. Cement mortar
4. Gauged mortar
5. Gypsum mortar.

#### **1. Lime mortar:**

In this type of mortar, the lime is used as binding material. The lime may be fat lime or hydraulic lime.

The fat lime shrinks to a great extent and hence it requires about 2 to 3 times its volume of sand. The lime should be slaked before use. This mortar is unsuitable for water-logged areas or in damp situations.

For hydraulic lime, the proportion of lime to sand by volume about 1:2 or so. This mortar should be consumed within one hour after mixing. It possesses more strength and can be used in situations.

The lime mortar has high plasticity and it can be placed. It possesses good cohesiveness with other surfaces and shrinks very little. It is sufficiently durable, but it hardens slowly. It is sufficiently used for lightly loaded above-ground parts of buildings.

## **2. Surkhi mortar**

This type of mortar is prepared by using fully surkhi instead of sand or by replacing half of sand in case of f. mortar. The powder of surkhi should be fine enough to IS Sieve No. 9 and the residue should not be more than 10% by weight.

The surkhi mortar is used for ordinary masonry work of all in foundation and superstructure. But it cannot be used for plastering or pointing since surkhi is likely to disintegrate after some time.

## **3. Cement mortar**

In this type of mortar, the cement act as binding material. Depending upon the strength required and importance of work, the proportion of cement to sand by volume varies from 1 : 2 to 1 : 6 or more. It should be noted that surkhi and Lime mortar are not chemically inert substances and hence they cannot be used as adult with matrix as cement. Thus the sand only can be used to form cement mortar.

The proportion of cement with respect to sand should be determined with due regard to the specified durability and working condition. Cement mortar is used where a mortar of high strength and water-resisting properties is required such as underground constructions and water salt soils, etc.

## **4. Gauged mortar**

To improve the quality of lime mortar to achieve early strength, the cement is sometimes added to it. This is known as the gauging. It makes lime mortar economical and strong dense. The usual proportion of cement to lime by volume is about 1:6 to 1:8. It is also known as the composite mortar or lime-cement and it can also be formed by the combination of cement and clay mortar may be used for bedding and for thick brick walls.

## **5. Gypsum mortar**

These mortars are prepared from gypsum binding materials.

### **3.2.4. Preparation of Cement Mortar**

This mortar does not require pounding or grinding. The cement and sand are mixed in required proportions in dry state on a watertight platform or steel trough. The mixing in dry state is done twice or thrice. The water is then added and the ingredients are again thoroughly mixed.

### 3.2.5. USES OF MORTAR

#### **Mortar is used**

1. In masonry for binding, the stones or bricks together.
2. To provide a hard, smooth covering surface for wall and floors etc.
3. To form an even bed for the stones or bricks or broken stones in a structure and thus to distribute the super incumbent weight uniformly.
4. Used to joint the pipes.
5. To conceal the defective workmanship and also to fill up the joints and cavities and thus to make the wall weather tight.
6. As a matrix in concrete for holding the broken stones together and to form into a solid mass.
7. To improve the appearance of a structure in general.

#### 3.2.6. Precautions in using mortar

Following precautions are to be taken while making use of mortar:

1. After preparation, the mortar should be consumed as early as possible. The cement mortar should be consumed within 30 minutes after adding water and for this reason, it is advisable to prepare cement mortar of one bag of cement at a time.
2. The setting action of mortar is affected by the presence of frost. It is therefore advisable to stop the work in frosty weather or to execute it with cement mortar which will set before it tries to freeze.
3. The presence of water in mortar is essential to cause its setting action. Hence the building units should be soaked in water before mortar is applied.
4. The construction work carried out by mortar should be kept damp or wet by sprinkling water to avoid rapid drying of mortar.
5. The mortar should not contain excess water and it should be as stiff as can be conveniently used.

#### 3.2.7. Tests for mortar

##### **a) Following procedure is adopted to carry out this test:**

- i. The two bricks are placed at right angles to each other.
- ii. The mortar is placed to join them so as to form a horizontal joint. If the size of bricks is 19 cm x 9 cm x 9 cm.
- iii. The upper brick is suspended from an overhead support and the weights are attached to the lower brick. The weights are gradually increased till separation of bricks occurs. The ultimate adhesive strength of mortar per mm<sup>2</sup> area is obtained by dividing maximum load by 81 cm<sup>2</sup>.

### b) Crushing strength

For this test, the brickwork is carried out with mortar to be tested. A sample of this brickwork is taken and it is gradually loaded in a compression testing machine till failure occurs due to crushing. The ultimate crushing strength is obtained by dividing maximum load with cross-sectional area.

### c) Tensile strength

For this test, the mortar to be tested is placed in the briquette moulds.

The briquettes are then tested in a tension machine. The cross-sectional area of central portion is 38 mm x 38 mm or 14.44 cm<sup>2</sup>.

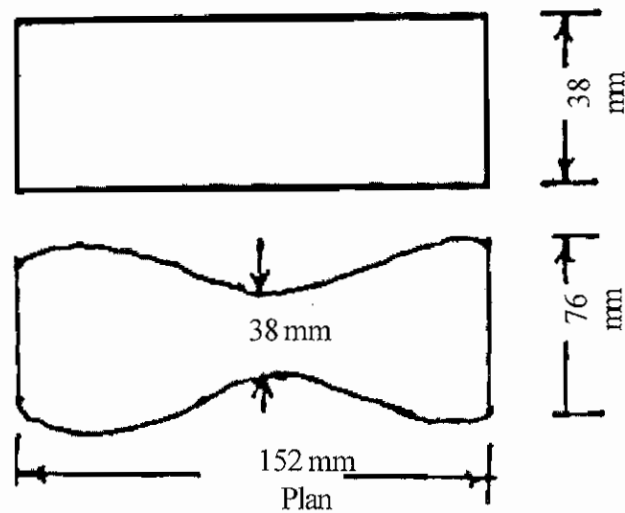

**Fig. Briquette for tensile strength of mortar**

## QUESTIONS

### Part A

#### I. CHOOSE THE BEST ANSWER

- 1) Which property is necessary for the mortar to cohabit with brick and stone.  
a) Adhesive property   b) Non-Adhesive property   c) Hardness   d) mild property
- 2) The sieve used to add sand in surki instead of lime.  
a) I.S. Sieve No.9   b) I.A. Sieve No.6   c) S.I. Sieve No.8   d) A.I. Sieve No.9
- 3) In cement mortar the ratio of cement sand is  
a) 1:3 to 1:4   b) 1:2 to 1:6   c) 1:5 to 1:8   d) 1:4 to 1:7
- 4) The mortar prepared with small quantity of cement with Mud mortar.  
a) Lime mortar   b) Brickpowder mortar   c) Gauged Mortar   d) Gypsum Mortar
- 5) Prepared cement mortar consumed within the time.  
a) 60 mts.   b) 30 mts.,   c) 10 mts.,   d) 45 mts.
- 6) If high quantity of water added the material which loose its workability.  
a) Mortar   b) sand   c) cement   d) Lime.
- 7) Mortar which is prepared as a binding material.  
a) Gypsum mortar   b) Lime mortar   c) Gauged mortar   d) Brick powder Mortar

### PART-B

#### II) ANSWER IN ONE (OR) TWO WORDS:

- 1) Write two materials in Mortar.
- 2) What is the another name of sand.
- 3) For which the mortar is used to paste.
- 4) At what rate the mortar should be available.
- 5) Write about I.S. sieve used for brick powder mortar.
- 6) What should be done for the buildings plastered by mortar.

### PART-C

#### III) ANSWER IN ONE (OR) TWO SENTENCES:

- 1) What is cement mortar 1:3.
- 2) What is meant by mortar.
- 3) What is the contribution of sand in mortar.

- 4) What are the uses of cement mortar.
- 5) What are the types of mortar.

#### **PART-D**

#### **IV) ANSWER SHORTLY:**

- 1) What are the properties of Mortar.
- 2) Write short notes on a) Cement mortar, b) Gauged mortar
- 3) What are the points to be noted while using mortar.
- 4) What are the uses of mortar.

#### **PART-E**

#### **V) ANSWER IN DETAIL**

- 1) What are the types of mortar. Define them.
- 2) What are the uses of mortar and write the points to be noted while using them.

## **3.3. CONCRETE**

### **3.3.1. DEFINITION OF CONCRETE**

The word concrete in Tamil is learned as ROCK STONE but in formal tamil the word concrete is used. Process of mixing broken Granite metal or broken bricks with mortar in correct proportion is called concrete.

This granite broken metal or broken brick is called coarse aggregate. Jelly denotes coarse aggregates only. It diggers from fine aggregate.

The mortar may be cement sand or lime sand which is mixed with concrete when rod is reinforced with concrete then it is called reinforced concrete.

### **3.3.2. CONSTITUENTS OF CONCRETE AND THEIR REQUIREMENTS**

The materials that go to form concrete are :

1. Binding material, which is cement or lime.
2. Fine aggregate, which is sand or stone dust.
3. Coarse aggregate which are broken stone or broken brick.
4. Water.

Lime, cement and water are active constituents while fine and coarse aggregate are inert, i.e., chemically inactive substances. Each of the four ingredients has its separate function.

#### **Binding Material**

Cement or lime binds the individual units of aggregate (fine and coarse) into a solid mass by virtue of its inherent properties of setting or hardening in combination with water. It helps to fill the voids and gives density to the concrete.

#### **Fine Aggregate**

Sand or stone dust serves to fill the voids in coarse aggregate and reduce the quantity of cement.

#### **Coarse Aggregate**

Broken stone or broken brick acts as main filler and forms the main bulk of concrete, around the surfaces of which the binding materials adhere in the form of a film.

#### **Water**

Water which is suitable for drinking is used for concrete mixing. Water serves as three purposes in concrete mixing.

1. It distributes the cement or lime so that every particle of aggregate is coated by it and brought into intimate contact with each other.

2. It acts as a lubricant and gives workability to the mixture.
3. It chemically combines with the various compounds in cement or lime to form a binding medium for the pieces of aggregate. Water helps crystallisation and play an active part in contributing to the strength of the concrete. The ratio of the amount of water to the amount of cement by weight is termed as water cement ratio.

### 3.3.3. BULKING OF SAND

The presence of moisture in sand increases the volume of sand. This is due to the fact that moisture causes film of water around sand particles which results in the increase of volume of sand. For a moisture content about 5 to 8 per cent, this increase of volume may be as much as 20 to 40 per cent, depending upon the grading of sand. The finer the material, the more will be the increase in volume for a given moisture content. This phenomena is known as the bulking of sand.

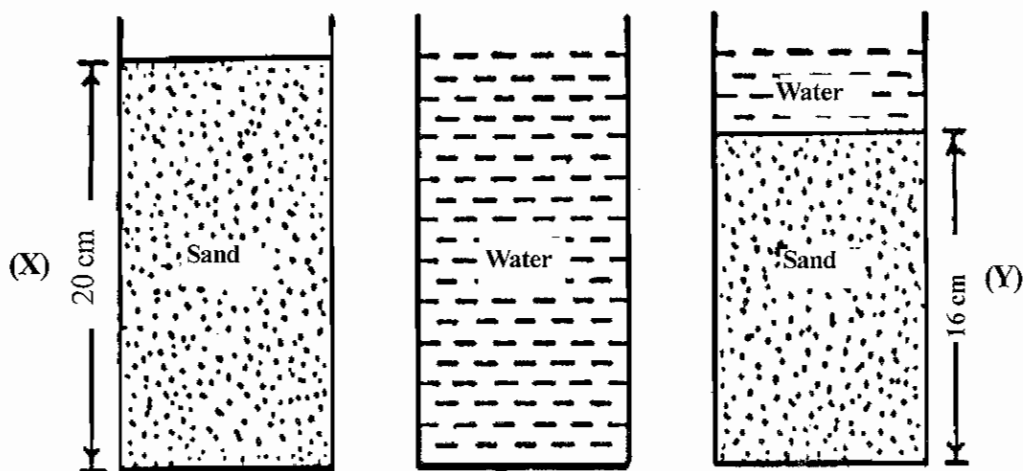

**Fig. 3.3.1. Bulking of sand**

When moisture content is increased by adding more water, the sand particles pack near each other and the amount of bulking of sand is decreased. Thus the dry sand and the sand completely flooded with water have practically the same volume.

A very simple test, may be carried out to decide the percentage of bulking of sand. Following procedure is adopted.

1. A container is taken and it is filled two-third with the sample of sand to be tested.
2. The height is measured, say it is (x) 20 cm.
3. The sand is taken out of container. Care should be taken to see that there is no loss of sand during this transaction.
4. The container is filled with water
5. The sand is then slowly dropped in the container and it is thoroughly stirred by means of a rod.



6. The height of sand is measured say it is (y) 16 cm.

$$\text{Then, Bulking of sand} = \frac{(x-y)}{y} \times 100$$

### 3.3.4. GRADING OF AGGREGATES

Grading of aggregate means particle size distribution of the aggregate. If all the particles of an aggregate were, of one size, more voids will be left in the aggregate mass. On the other hand an aggregate having particles of varying sizes will exhibit smaller voids. Principle of grading is that the smaller size, particles fill up the voids left in larger size particles. By adopting proper percentages of various sized aggregate, composite aggregate mix can be developed which will be thoroughly graded. Properly graded aggregate produces dense concrete and needs smaller quantities of fine aggregate and cement. The grading of aggregate is expressed in terms of percentages by weight retained on a series of sieves 80mm, 40mm, 20mm, 10mm, 4.75mm, 2.36 mm, 1.18mm, 600 micro, 300 mic and 150 mic are used for fine aggregate.

Gradation has an important effect on the workability and characteristics of fresh and hardened concrete. Gradation of aggregates is most important to produce workable concrete. A well graded concrete contains minimum voids to be filled by the cement paste. This means less quantity of cement and water which will 'further mean increased economy, higher strength, lower shrinkage and greater durability. Grading of fine aggregate has much effect on workability of concrete than grading of coarse aggregate. It is seen that very coarse sand are very fine sand is unsatisfactory for concrete making.

### 3.3.5. WATER-CEMENT RATIO

Water reacts, with cement chemically and causes setting and hardening of concrete. It is found theoretically that water required is about 0-50 to 0-60 time the- weight of cement.

1. Minimum quantity of water should be used to reasonable degree of workability
2. Water - Cement - ratio for structures which are exposed to weather should be carefully decided. For instance, for structures which are regularly wetting and drying, water cement ratio by weight should be 0-45 and 0-55 for thin sections and mass concrete respectively. For structures which are continuously under water, the water cement ratio by weight should be 0-55 and 0-65 for thin sections and mass concrete respectively.
3. A thumb rule for ordinary concrete given below assuming the materials are non-absorbent and dry may be adopted. Weight of water = 28% of the weight of the cement + 4% of the weight of total aggregates.

### 3.3.6. SLUMP TEST

This test is used to determine the consistency of workability of concrete and also the required amount of water. The slump test is now universally adopted both on the sites during the progress of the work and in the laboratory.

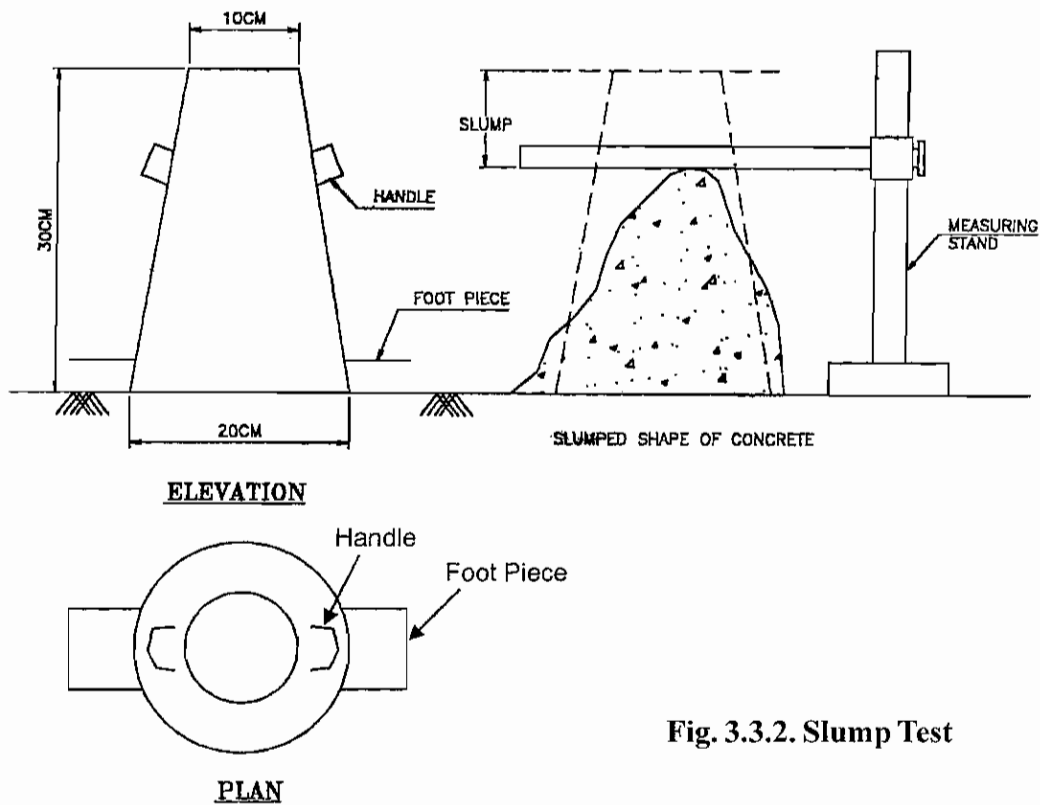

**Fig. 3.3.2. Slump Test**

### 3.3.7. PREPARATION OF CEMENT CONCRETE

Materials of concrete should be mixed thoroughly so that there is uniform distribution of materials in the mass of concrete. Also the mixing should ensure that cement paste completely covers the surface of aggregate. Mixing can be done either by hand or by machine.

#### 1. Hand Mixing

For hand mixing, the materials are stacked on a water tight platform, which may be either of wood, bricks or steel. The materials should be thoroughly mixed, at least three times, in dry condition before water is added. The prepared mix should be consumed in 30 minutes after adding water. Mixing by hand is allowed in case of small works or unimportant works. Where small quantity be adopted, it is advisable to use 10 percent more cement than specified.

#### 2. Machine Mixing

Machine mixing is carried out by batch mixers or by continuous mixers. Batch type mixers are mostly adopted. Water should enter the mixer at the same time, or before the other materials are placed. The mixing time should be atleast one minute and preferably two minutes. The concrete discharged by the mixer should be consumed within 30 minutes. The mixer should be cleaned well after use. This type of mixing is more efficient.

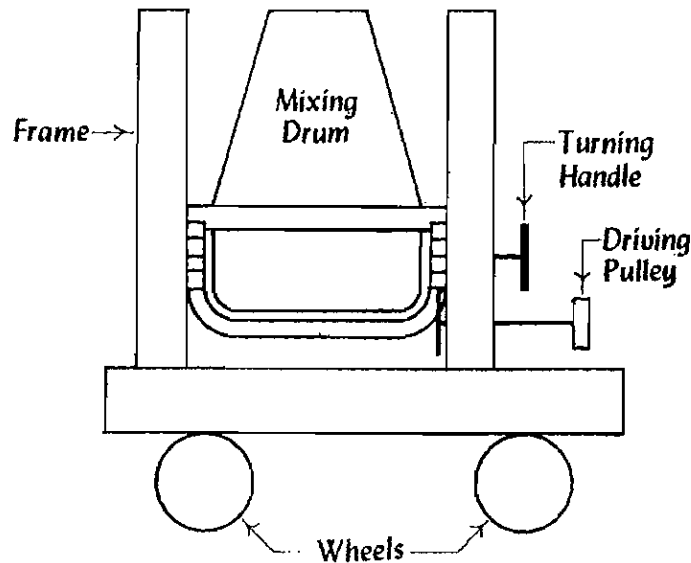

**Fig. 3.3.3. Preparation of Cement Concrete**

### **3.3.8. CONSOLIDATION OR COMPACTION OF CONCRETE**

The object of consolidation of concrete is to eliminate air bubbles and thus to obtain maximum density to concrete. An intimate contact between concrete and reinforcement is ensured by proper consolidation. The process of consolidation of concrete can be done with the hand or with the help of vibrators.

#### **1. Hand Consolidation**

It is done with the help of steel tamping rods or timber screeds. Narrow and deep-members are compacted with tamping rods. The slabs and floors are tamped with the help of screeds. Compaction should be done in layers of 300 mm for mass concrete and 150 mm for reinforced concrete.

#### **2. Mechanical Compaction**

Mechanical compaction of concrete in the formwork is carried out using mechanical devices called vibrators. The advantages of using vibrators are,

1. It is possible to make a harsh and stiff concrete mix.
2. It is possible to improve the quality of concrete.
3. It is possible to deposit concrete in small openings and in places where it will be difficult to deposit by hand methods.

### **3.3.9. CURING OF CONCRETE**

Curing is the operation by which moist conditions are maintained on finished concrete surface to promote continued hydration of cement. If proper curing is not done, that concrete will not acquire its

full intended strength. Moreover, shrinkage cracks will develop in the concrete. Curing also brings about improvement in durability, impermeability, wear and weather resisting qualities. There are several methods of curing. Adoption of specific method depends upon the nature of work and the climatic conditions.

### **3.3.10. Properties of Cement Concrete**

Cement concrete possesses the following important properties.

1. It has a high compressive strength.
2. It is free from corrosion and there is no appreciable effect of atmospheric agents on it.
3. It hardens with age and the process of hardening continues for a long time after the concrete has attained sufficient strength.
4. It is proved to be more economical than steel
5. It binds rapidly with steel and as it is weak in tension. Steel reinforcement is placed in cement concrete at suitable places to take up the tensile stresses. This is termed as “Reinforced cement concrete or simply “R.C.C.”
6. Due to non absorption of water on the surface it gets the property of shrinkage. If curing is not done shrinkage and crack occurs.
7. It has a tendency to be porous. This is due to the presence of voids which are formed during and after its placing.
8. It forms a hard surface, capable of resisting abrasion.

### **3.3.11. USES OF CONCRETE**

Concrete is used for a great variety of purposes among which may be mentioned foundations for masonry works, especially in damp soil or under water, terrace roofs and floors, walls, arches, dams, bridges, piers, breakwaters, lighthouses, retaining walls, sea walls etc. For most of these purposes it is superior to masonry in durability, strength and economy.

### **3.3.12. TYPES OF CONCRETE**

There are several types of cement concretes which can be developed to suit the specific requirements. Such concrete are developed either by varying the proportions of usual cement concrete or by adding some additional constituents.

1. **Cement concrete** : Cement concrete is prepared with jelly. This concrete is used for the construction of Beam, Pillar, Roof, Floor and Dam. Those are used to make compression member 40 mm jelly, 20 mm jelly are also used in cement concrete, these are classified as plain cement concrete and reinforced.

2. **Lime concrete:** This concrete is made by mixing lime mortar with 20 mm broken stone. These concrete are used for foundation piers etc.
3. **Light weight concrete:** It is ordinary cement concrete and that special light weight concrete can also be obtained by adding such agent which either develop gas or foam, during the process of mixing of concrete which develops porous cellular structure of concrete.
4. **Air entrained concrete :** This concrete is developed by either using air-entraining cement or other such agents.
5. **No fines concrete :** This cement concrete dose not have any fine aggregate. It is a mixture of cement, coarse aggregate and water only.
6. **Vacuum concrete :** Only about half of the water added in concrete goes into chemical combination and the remaining water is used to make concrete workable. After laying, concrete, water which was making concreting workable is extracted by a special method known as vaccum method. This water left in this concrete is only that which is to go in chemical combination and hence resulting concrete becomes very strong.
7. **Water proof concrete :** This concrete is prepared by adding some water proofing or waterrepellant compound in the concrete. This concrete is used for rendering structures water proof.
8. **Reinforced cement concrete :** Ordinary cement concrete is very weak in tension, but very strong in compression. Steel rods may be embedded on the tension side of the member. Such concrete in which steel rods are embedded is called reinforced cement concrete, abbreviated as R.C.C.
9. **Pre-Stressed Concrete:** It is also reinforced cement but steel rods are pre-stressed before embedding in the concrete. These rods remain pre-stressed even after the concrete has fully set. Elements of this concrete when subjected to bending do not develop cracks. Pre-stressed concrete saves as much as 50% of concrete.
10. **Cellular or aerated Concrete :** This, concrete is made light by introducing air bubbles throughout the mass. It is useful for roofslab and precast units in partitions. It is made by adding aluminium powder to a rather wet mix of cement, sand, lime, and water. The mass begins to rise due to hydrogen bubbles evolved by the chemical action and there by cells are formed in the concrete.
11. **Pre-cast Concrete :** Pre-cast concrete is an ordinary cement concrete, but prepared not at the site of use, but in factory, where as cast-in-situ concrete is ordinary cement concrete which is prepared at the site of its actual use.

### 3.3.13. SAFETY PRECAUTION TO BE TAKEN WHILE LAYING OF CONCRETE

Concrete, as it comes out of the mixer as it is ready for use on the form work. The type of equipment to be used for transport of concrete depends on the nature of work, height above ground level and distance between the points of preparation and placing of concrete. For ordinary building

works, human ladder is formed and concrete is conveyed in pans from hand to hand. For important works, various mechanical devices such as dumpers, track mixers, buckets, chutes, belt conveyors, pumps, hoist etc. may be used. The two important precautions necessary in transportation of concrete are as follows:

The concrete should be transported in such a way that there is no segregation of the aggregates and no spilling of concrete. Under no circumstances water should be added to the concrete during its passage from the mixer, to, the form work.

The concrete should be placed and compacted before its setting starts. Following precautions should be adopted while placing the concrete.

The form work of the surface which is to receive fresh concrete should be properly cleaned, prepared and well watered. It is desirable to deposit concrete as near as practicable to its final position.

While placing concrete, the position of form work and reinforcement should not be disturbed. To avoid segregation, concrete should not be dropped from height more than one metre. Concrete should be laid continuously.

Thickness of concrete layer should not be more than 30-45cm in case of mass concrete and 15-30cm in case of R.C.C. works. Concrete should be thoroughly worked around the reinforcement and tapped in such a way that no honeycombed surface appears on the removal of the form work. Concrete should be placed on the form work as soon as possible. But in no case, it should be placed after 30 minutes of its preparation.

## QUESTIONS

### PART - A

#### I. CHOOSE THE BEST ANSWER

- 1) Concrete is
  - a) lime mortar
  - b) concrete
  - c) Jelly
  - d) mortar
- 2) The other name of broken brick or broken stone.
  - a) Jelly
  - b) small jelly
  - c) Big jelly
  - d) sand
- 3) Fine Jelly is
  - a) sand
  - b) cement
  - c) water and sand
  - d) sand jelly
- 4) The Dummy part in concrete
  - a) Lime cement
  - b) Cement and water
  - c) water and sand
  - d) sand jelly
- 5) Admixture in cement by chemical reaction getting bonding property.
  - a) water
  - b) sand
  - c) Jelly
  - d) Rod
- 6) Percentage of moisture in bulking of sand.
  - a) 5 to 8%
  - b) 6 to 9%
  - c) 4 to 7%
  - d) 3 to 6%
- 7) Additional % of sand added in Hand mix.
  - a) 10%
  - b) 20%
  - c) 40%
  - d) 60%
- 8) Curing period for the building constructed by Portland cement.
  - a) 6 to 13 days
  - b) 8 to 9 days
  - c) 4 to 9 days
  - d) 7 to 14 days
- 9) Forming air bubbles and concrete prepared for low weight.
  - a) Cellular concrete
  - b) Vaccum concrete
  - c) Air tight concrete
  - d) Low weight concrete.

### PART-B

#### II) ANSWER IN ONE (OR) TWO WORDS:

- 1) How rock stone meant in Tamil.
- 2) Write any materials mixed in concrete.
- 3) How we are calling sand.
- 4) What is the test conducted for sand.
- 5) In how many method concrete is prepared.

- 6) What is the name of test conducted for water cement Ratio.
- 7) Write one of the uses of concrete.

#### **PART-C**

#### **III) ANSWER IN ONE (OR) TWO SENTENCES:**

- 1) Define C.C.1:2:4.
- 2) What is the difference between reinforced concrete and plain concrete.
- 3) What are the materials in concrete.
- 4) What is meant by segregating the jelly.
- 5) What are the methods of preparing concrete.
- 6) What is meant by water cement ratio.
- 7) What is bulking of sand.
- 8) What is C.C.1:2:4.

#### **PART-D**

#### **IV) ANSWER SHORTLY:**

- 1) What is bulking of sand. Define it with sketch.
- 2) What are the rules to be followed while preparing concrete.
- 3) What are the properties of concrete.
- 4) What are the uses of concrete.
- 5) Define the preparation of concrete in mixer machine with a neat sketch.
- 6) Define using of concrete.

#### **PART-E**

#### **V) ANSWER IN DETAIL:**

- 1) Define the materials in concrete.
- 2) Write the types of concrete and define.
- 3) Explain the preparation of concrete.



## UNIT IV

### 4.1. TIMBER

#### 4.1.1. Introduction

The word timber is derived from an old English word timbrian which means to build. Following three terms are to be noted in connection with the timber.

##### 1. Converted timber

This indicates timber which is sawn and cut into suitable commercial sizes.

##### 2. Rough timber

This indicates timber which is obtained after felling a tree.

##### 3. Standing timber

This indicates timber contained in a living tree. The timber or wood as a building material possesses a number of valuable properties such as low heat conductivity amenability to mechanical working, small bulk density, relatively high strength etc.

#### 4.1.2. Uses of Timber in Construction

1. It can be used in form of piles, vertical posts, beams, lintels, doors and windows.
2. It can also be used as members of roofing trusses, ridge, truss and rafter.
3. It is used as formwork for cement concrete structures. It is very much used in timbering the deep trenches.
4. It is an important material for furniture making. It is very much used in making sports goods, musical instruments, well curbs, agricultural implements etc.
5. It is very much used for railway sleepers.

It can be said that there is no engineering field, where timber is not used one way or the other.

#### 4.1.3. TYPES OF TIMBER

##### 1. Teak

Its colour is yellow to dark brown. It is used for ship building, railway sleepers, railway carriages and furniture. It can be used for structural or decorative purposes. It is a costly timber and hence used for costly and specialized works. It can be easily seasoned. It shrinks very little. It can be worked easily and finally varnished. Its fibres are straight. It does not warp due to shrinkage. It contains such resinous materials which acts as white ant resistant. Its colour is yellow to dark brown.

## 2. Sal

Its colour is brown. It is hard, fibrous and close grained. It does not take up a good polish. It requires slow and careful seasoning. It is durable under, ground and water. Its weight after seasoning is  $8000 \text{ N/m}^3$ . It is used for railway sleepers, ship building, bridges, structural work etc.

## 3. Mango

This tree is found practically in all over India. It is used for cheap furniture, packing boxes, cabinet work, panel for doors and windows. Its colour is deep grey, it is easy to work. It is moderately strong and weighs  $6550 \text{ N/m}^3$ .

## 4. Jack

Its colour is yellow when freshly cut and it darkens with age. It is compact and even grained. It is moderately strong. It is easy to work. It takes a good finish. It maintains its shape well. Its weight after seasoning is  $5950 \text{ N/m}^3$ . It is used for plain furniture, boat construction, well curbs, doors and windows, panels, cabinet making etc.

### 4.1.4. DEFECTS IN TIMBER

#### Defects due to natural forces

The main natural forces responsible for causing defects abnormal growth and rupture of tissues.

1. Burls
2. Knots
3. Rind galls
4. Shakes
5. Twisted fibers
6. Wind cracks

#### 1. Burls

These are also known as the excrescences and they are particularly formed when a tree has received shock or injury in its young age.

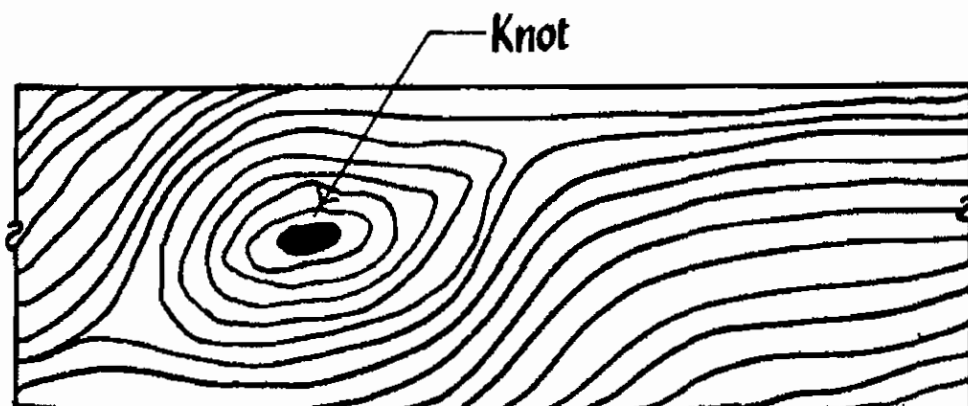

Fig. 4.1.1. Knots

## 2. Knots

These are the bases of branches or limbs which are broken or cut off from the tree. The portion from which the branch is removed receives nourishment from the stem for a pretty long time and it ultimately results in the formation of dark, hard rings which are known as knots. As continuity of wood fibres is broken by knots, they form a source of weakness.

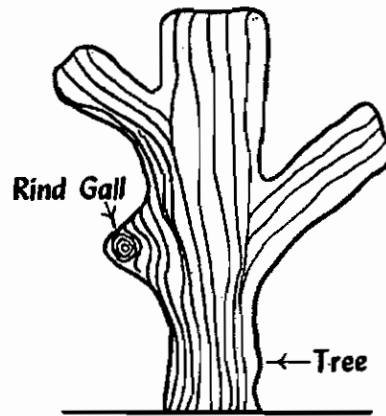

Fig. 4.1.2. Ring gall

## 3. Rind Galls

Rind galls are due to wrong cut of a tree. Hence peculiar curved swellings found on the body of a tree are known as rind galls. They develop at points from where branches are improperly cut and removed.

## 4. Shakes

These are cracks which partly or completely separate the fibres of wood. Following are the different varieties of shakes.

### Cup Shakes

These are caused by the rupture of tissues in circular direction. It is a curved crack and it separates partly one annual ring from the other. It develops due to non-uniform growth. It may not prove to be harmful if it covers only a portion of ring.

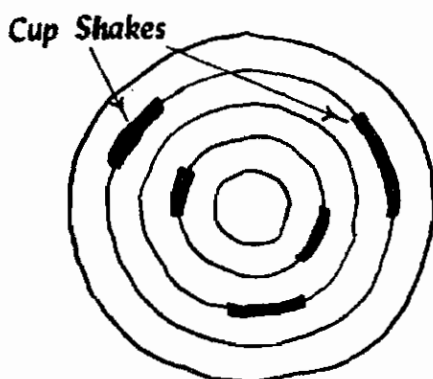

Fig. 4.1.3. Cup Shakes

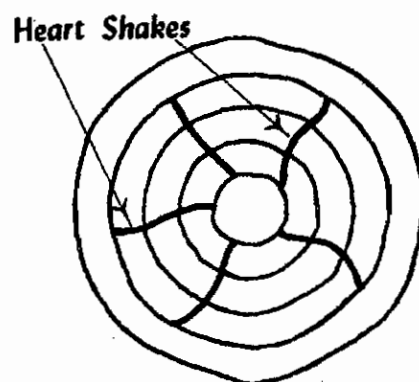

Fig. 4.1.4. Heart Shakes

### Heart Shakes

These cracks occur in the centre of cross-section of tree and they extend, from pith to sap wood in the direction of medullary rays. These cracks occur due to shrinkage of interior part of tree which is approaching maturity. Heart shakes divide the tree cross-section into two to four parts.

### Ring shakes

When cup shakes cover the entire ring they are known as ring shakes.

### Star shakes

These are cracks which extend from bark towards the sap wood. They are usually confined upto the plane of sap wood.

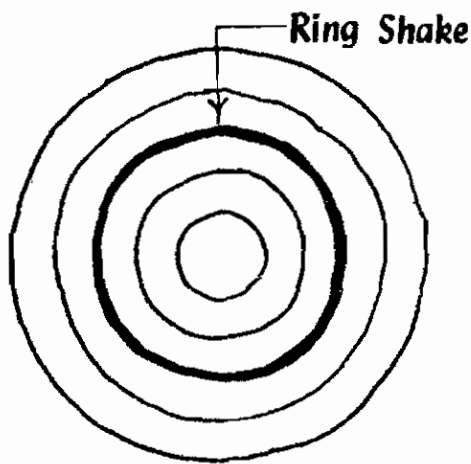

Fig. 4.1.5. Cup Shakes

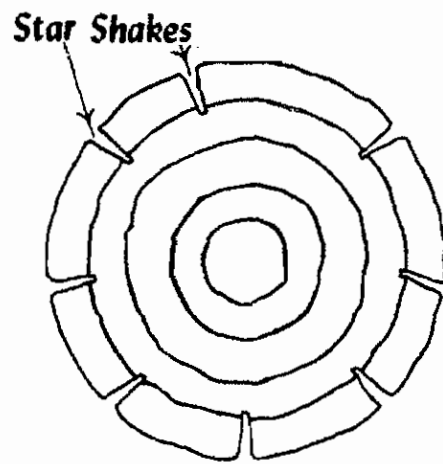

Fig. 4.1.6. Heart Shakes

### Radial shakes

These are similar to star shakes. But they are fine, irregular and numerous. They usually occur when tree is exposed to sun for seasoning after being fell down.

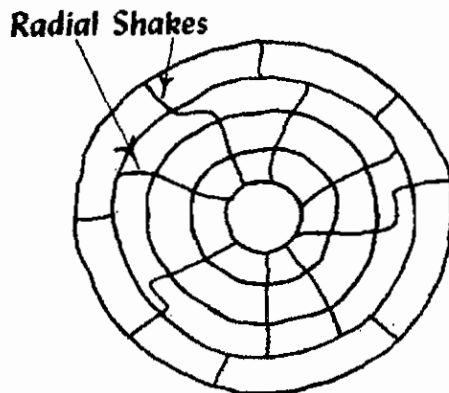

Fig. 4.1.7. Radial Shakes

### Twisted fibres

These are also known as wandering hearts and they are caused by twisting of young trees by fast blowing wind.

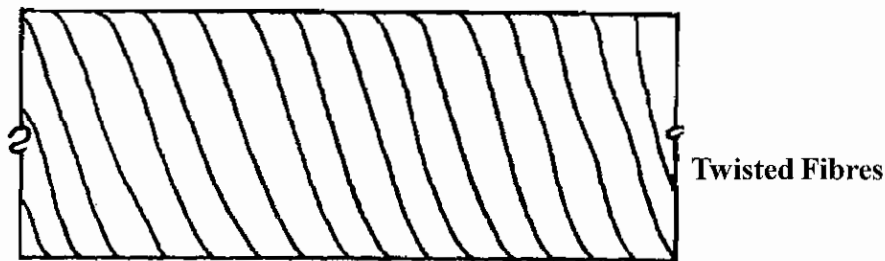
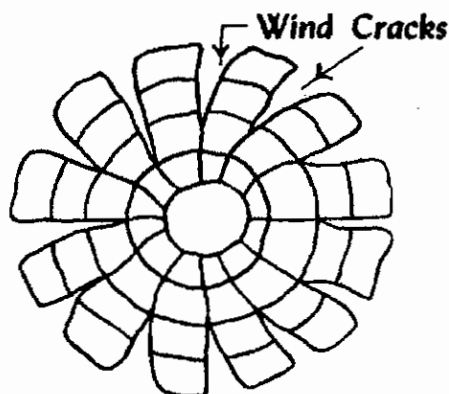

Fig. 4.1.8. Twisted fibres

### 6. Wind Cracks

If wood is exposed to atmospheric agencies, exterior surface shrinks. Such a shrinkage results into cracks and these are known as wind cracks.



4.1.9. Wind Cracks

### 4.1.5. Seasoning of Timber

When a tree is newly felled it contains about 50 percent or more of its own by weight as water. This water is in the form of sap and moisture. Water is to be removed, before timber can be used for any engineering purpose. Removal of water from timber is known as "Seasoning of timber".

#### Objective of Seasoning

Seasoning of timber is carried to achieve the following objects.

1. To allow timber to burn readily, if used as fuel.
2. To decrease the weight of timber and thereby to lower the cost of transport and handling.
3. To impart hardness, stiffness and strength to timber.

4. To maintain the shape and size of the components of the timber articles which are expected to remain unchanged in form.
5. To make timber easily workable and to facilitate operations during conversion.
6. To make timber safe from the attack of fungi and insects.
7. To reduce the tendency of timber to crack, shrink and warp.

#### 4.1.6. Methods of Seasoning of Timbers

Methods of seasoning can broadly be divided into the following two categories.

1. Natural seasoning
2. Artificial seasoning.

##### 1. Natural Seasoning

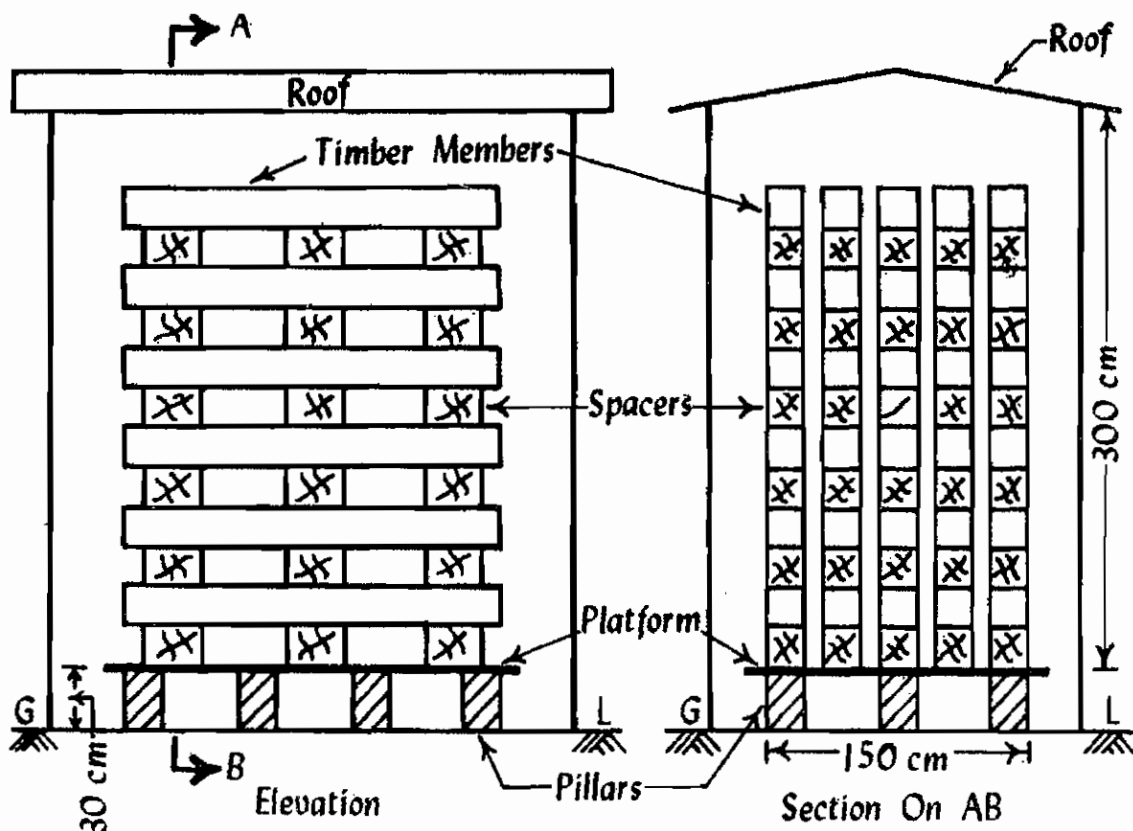

Fig. 4.1.10. Natural Seasoning

In this method, timber logs are sawn into planks or other marketable sizes immediately after felling the tree. The sawn timber is stacked under a covered shed. Sawn timber is stacked in such a way that sufficient space is left around each sawn piece, so that free circulation of air may take place without any

difficulty. Timber pieces may be stacked horizontally or vertically. But horizontally stacking arrangement is the most common method. The platform where stack is to be erected should be raised from the adjoining ground by at least about 300 mm. The stack is prepared by laying layers of sawn pieces in cross wise directions in alternate layers, length of the stack is equal to length of timber pieces. Width and height of the stack are restricted to about 1.5 m and 3 m respectively. A number of such stacks may be constructed under the same shed. Minimum distance between adjacent stacks should be kept about 600 mm. This method of seasoning is also called “air seasoning”. Natural air remains circulating around each piece of the stacks and in due course of time, which depends upon the climatic conditions and the type and size of the timber, seasoning is brought about.

## **2. Artificial Seasoning**

1. Boiling
2. Chemical seasoning
3. Electrical seasoning
4. Kiln seasoning
5. Water seasoning

### **Boiling**

In this method, timber is immersed in water and the water is then boiled for about three or four hours. It is then dried very slowly. Instead of boiling in water, timber may be exposed to the action of hot steam. This method of seasoning proves to be costly.

### **Electrical seasoning**

In this method, use is made of high frequency alternating current issued on timber. When it is green, it offers less resistance to the flow of electric current. The resistance increases as the wood dries internally, which also results in the production of heat. This method is not adopted as it is not economical but very costly.

### **Kiln seasoning**

This method of seasoning is carried out in air tight chambers or ovens. Converted timber pieces are stacked inside the chamber such that spaces are left for free circulation of air. Now air, fully saturated with moisture and heated about 40°C is forced inside of the chamber. The heated air gradually enters the inside of the timber pieces and the moisture content in the timber is gradually reduced.

## **4.1.7. Wood Based Products or Industrial Timber**

### **1. Veneers**

The primary process in the manufacture of wood based products is veneering which produces thin sheets of wood known as veneers. The logs to be used for this purpose are kept in wet storage to

avoid end splitting and are softened by heating with hot water or steam and the bark is removed. The log is then cut to veneers. Depending on the cutting process, the veneers are classified as rotary veneers and sliced veneers.

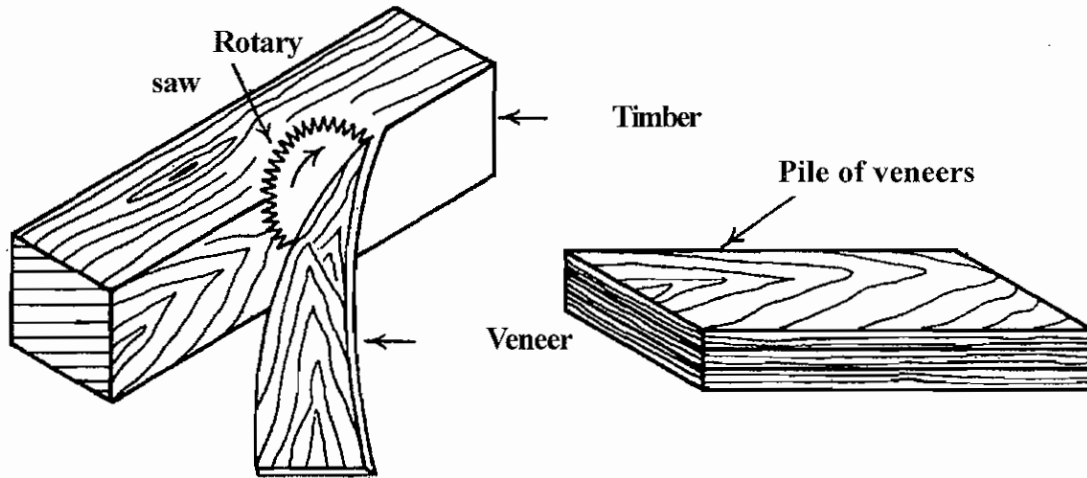

Fig. 4.1.11. Veneers

## 2. Ply woods

Plywood is in the form of boards from thin layers of wood of veneers. Veneers are placed one above the other with the direction of grains of successive layers at right angles to each others. To paste this wet and dry adhesives are used pasted plywood boards are cut with the help of hydraulic machine.

### Uses of plywood

1. It gives decorative appearance
2. It will not expand under weathering conditions because it is manufactured as a flexible material.
3. It is used to make doors and it is easy to handle.

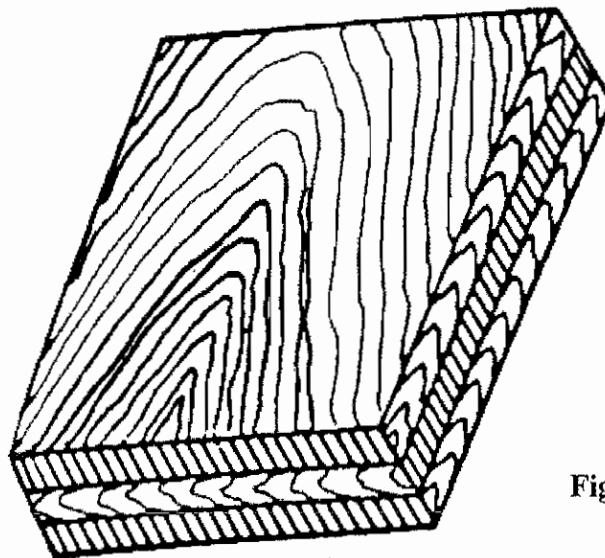

Fig. 4.1.12. Plywood



### 3. Fibre Boards

The resulting material is called the fibre board. These are rigid boards of thickness varying from 3mm to 12mm. They are also known as “pressed wood” or “reconstructed wood”.

### 4. Laminated Board

Laminated board is a board having a core of strips 1 cm to 5 cm in thickness, glued together face to face to form a slab which in turn is glued to two or more outer veneers, with direction of the grain of the core strips running at right angles to that of the adjacent outer veneers.

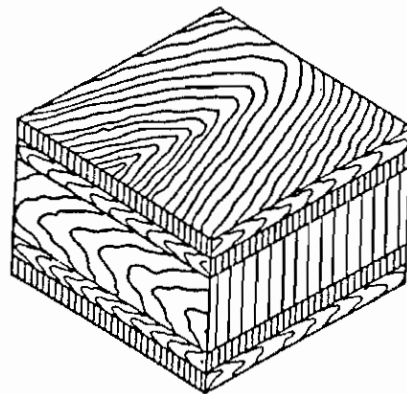
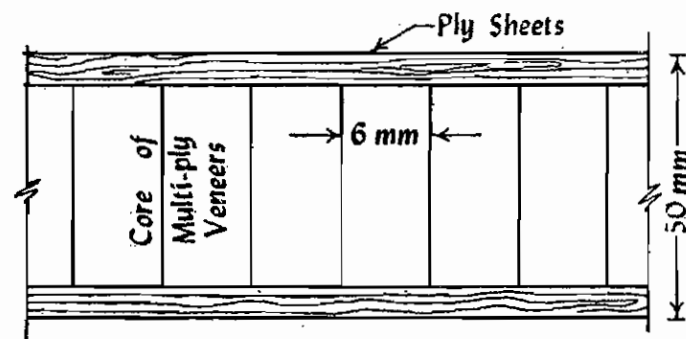

**Fig. 4.1.13. Laminated Board**

### 5. Straw Board

These are prepared with chipped straw and gum in the form of boards. They are used for ceiling and the inside facing wall of auditorium as acoustic materials.

## QUESTIONS

### PART - A

#### I. CHOOSE THE BEST ANSWER

- 1) The curved swelling defect in Timber.  
a) Burls                      b) Air crack                      c) shakes                      d) Rind galls
- 2) The timber used as sleeper in rail track.  
a) Mango tree                      b) sal tree                      c) Jack tree                      d) Teakwood
- 3) The colour of Sal tree  
a) Red                      b) Yellow                      c) blackish yellow                      d) Black
- 4) Name of disease affecting the growth of tree in the early age.  
a) Burls                      b) Rind galls                      c) Shakes                      d) Air crack.
- 5) The ash colour tree  
a) Teak                      b) Sal tree                      c) Mango tree                      d) Jack tree
- 6) The tree used for manufacturing cot and bureau.  
a) Mango tree                      b) Sal tree                      c) Jack tree                      d) Teak wood
- 7) Name of disease affecting the growth of tree penetrating from the crack to core of tree.  
a) Cup shake                      b) Radial shake                      c) star shake                      d) Twisted fibres
- 8) Temperature for seasoning of timber in kiln seasoning.  
a) 50° c to 38° c                      b) 7c° to 40° c                      c) 90° c to 42° c                      d) 110°c to 44°c

### PART-B

#### II) ANSWER IN ONE (OR) TWO WORDS:

- 1) Mention the English word noting wood.
- 2) Mention any two diseases occur in wood due to natural force.
- 3) Mention any one use of Teak wood.
- 4) Mention anyone use of Sal tree.
- 5) Mention any one use of Mango tree.
- 6) Write the allowable percentage of moisture content in Teak wood after seasoning.
- 7) Write any two artificial seasoning of timber.

- 8) How long the timber is dipped in Boiling method of seasoning.
- 9) What is meant by Industrial timber.

#### **PART-C**

#### **III) ANSWER IN ONE (OR) TWO SENTENCES**

- 1) Write any two type of Industrial timber.
- 2) What is the allowable percentage of seasoning of timber.

#### **PART-D**

#### **IV) ANSWER SHORTLY**

- 1) Write the types of tree.
- 2) What is seasoning of timber.
- 3) Write the types of seasoning of timber.
- 4) What is the purpose of seasoning the timber.
- 5) Write the defects of timber.
- 6) Write short notes on Mango tree.
- 7) What are the uses of Ply wood.
- 8) Write short notes on Teak wood.
- 9) Write the types of trees and their properties and uses.
- 10) Tabulate the various defects of trees and define.
- 11) Write the types of seasoning of timber and define.

#### **PART-E**

#### **V) ANSWER IN DETAIL**

- 1) Define the Natural seasoning of timber.
- 2) Define the types of trees.
- 3) What are the uses of trees in construction work.
- 4) Define two timber materials.

## 4.2 LIME

### INTRODUCTION

Lime is a binding material. Several buildings in India used Lime for the constructions.

#### 4.2.1. TYPES OF LIME

Generally Lime is classified in two types such as Fat lime and Hydraulic Lime.

#### 4.2.2. FAT LIME

Due to high calcium content it is called high Calcium lime and it is also called in several names such as white lime, pure lime. If we get pure lime in nature it is called as quicklime. When Fat lime is boiled in water the cubic measurement increases to 2.5. This lime contains 95% calcium oxide.

#### Properties of Fat Lime

- 1) It hardens slowly.
- 2) Plasticity is high.
- 3) Easy soluble in water.
- 4) It is in pure white colour
- 5) Quickly soluble in water.

#### Uses of Fat Lime

- 1) Useful for whitewashing the plastered walls.
- 2) Added with sand and the lime mortar is used for brick work and stone masonry work.
- 3) Brick bat mixed with the construction of mortar called surki possesses setting. This is used for big compound wall and base.

#### 4.2.3. Hydraulic Lime

It sets under water. There is small quantity of clay content and Iron Oxide. According to the quantity of Clay content it is classified in three types.

- 1) Feebly hydraulic lime
- 2) Moderately hydraulic lime
- 3) High Quality hydraulic lime.

Feebly hydraulic lime having 5 to 10%. Clay content is easily soluble in water. It takes 3 weeks to settle.

Moderately hydraulic lime having 11 to 21%. Clay content takes 2 hours for dissolving. It takes one (or) two weeks to settle.

High quality hydraulic lime having 21 to 30%. Clay soil will not easily soluble. But settle in one (or) two days.

#### 4.2.4. DIFFERENCE BETWEEN FAT LIME AND HYDRAULIC LIME

S.No.	Property	Fat Lime	Hydraulic Lime
1)	Main Ingledient	95% calcium carbonate 5% clay soil	5 to 30% clay soil Small quantity of ferrous Oxide.
2)	Slacking action	Quickly slacks. At that time 2 times increases. Heat and sound occurs.	Slow slaking property. No sound and heat releases when slakes.
3)	Setting action	Slow setting property. Absorbs carbon-di-Oxide from the atmosphere and converts as calcium carbonate.	Sets under water. It changes as tri calcium Aluminate and di calcium Silicate when combines with water.
4)	Hydraulic property	No hydraulic property	Has hydraulic property
5)	Colour	White	Moderate white
6)	Strength	Not so hard	Highly Hard
7)	Uses	Useful for white washing	To prepare mortar by adding with sand mortar is used for the masonry work in seepage areas.

#### 4.2.5. PREPARATION OF LIME MORTAR

Required quantity of lime mortar is prepared by grinding. If requirement is low mortar is prepared by pounding.

##### **Pounding**

In this method pits are made in Hard floor and lining is done with bricks at the side and bottom of pit. Rectangular base of the pit is in 80 cm length and 40 cm breadth. Top portion is 180 cm length and 50 cm breadth. It is like a channel when seen. (Narrow at bottom wide at top) 4 to 5 members sits on both sides of pit and fills sand and dry lime and water is mixed and they beat this mixture with hard wooden stick to make it to a powder form. Required water is added to the requirement of consistency and beating is done for preparation of Mortar.

So this method is useful for small quantity of lime mortar.

##### **Method of Grinding**

Mortar is prepared in Grinding mill and it is classified as follows:

- 1) Grinding mill with human power.
- 2) Grinding mill with electric power.

## 1. Grinding Industry with Human Power

It is also called as Khani. The following sketch clears the structure of the grinding mill of lime with oxen. Circle is formed by 6 m dia or 9 m dia. As showing the sketch 40 cm depth and 30 cm width channel is made in the radius of the circle. To grind the lime in the channel stone wheel is fixed and wheel axle is connected through the centre. At least 50 mm gap should be allowed on both side of the stone wheel where the wheel placed in the channel.

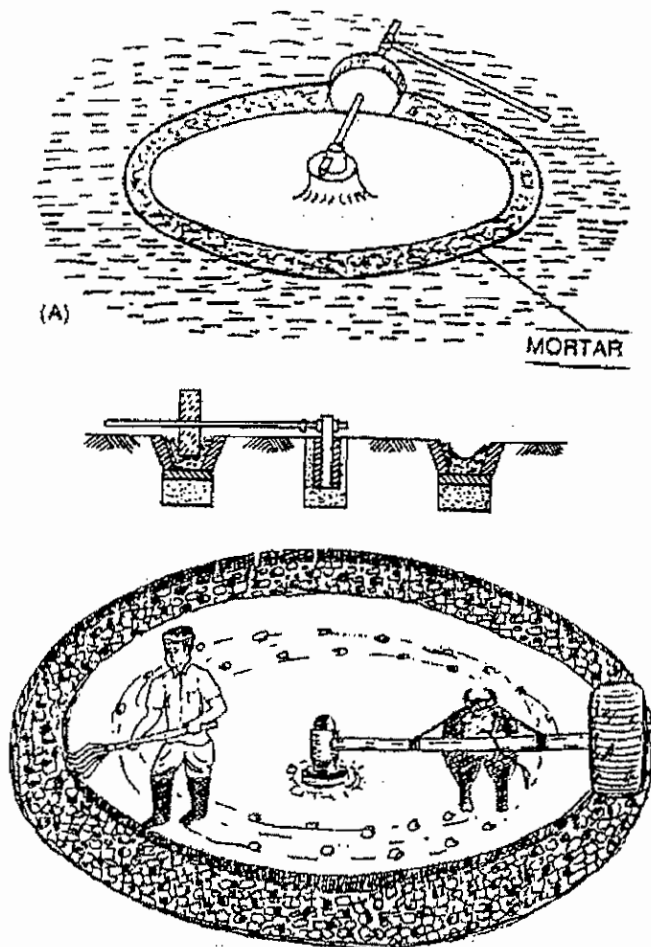

Fig. 4.2.1. Grinding Industry with Human Power

The mixture of sand and lime placed in the channel is grinded well when the labours rounding the mill simultaneously axle comes to other end. Whenever water is necessary it is added to get consistent mix and it is grinded well with the help of Kaddi the mixture in the channel is turned and grinded well.

## 2. Working of Grinding Mill with the help of Electric Power

We are preparing the lime mortar using Electric power instead of oxen we can see its structure in the figure. It contains a vessel and two cylinders. More (or) Less it is just like a grinder. The diameter of revolving drum is 180 cm to 240 cm dia.

The cylinders are fixed rigidly in the centre Axle. The sand, Lime is mixed with water in the revolving drum and electric power is switched on then the revolving drum revolves. It grinds well in the rigidly fixed cylinder. In this mill a large quantity of mixture is prepared in short time.

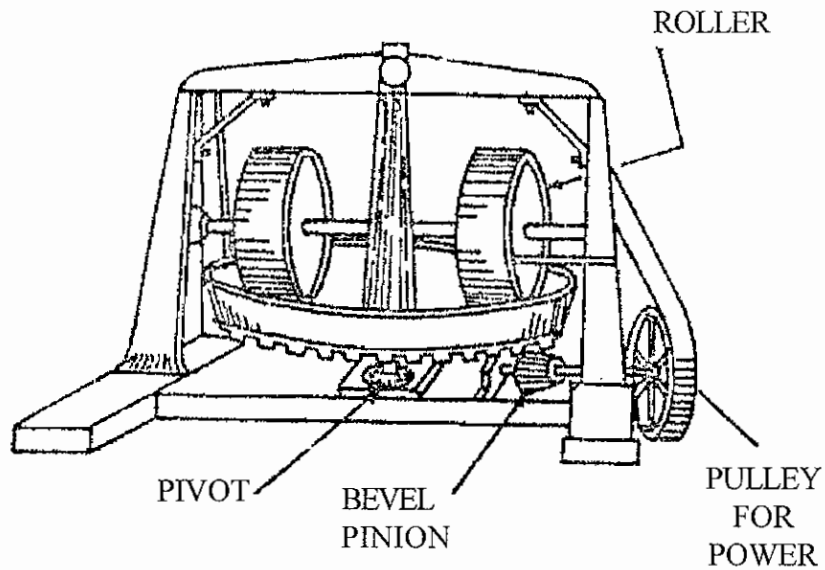

**Fig. 4.2.2. Working of Grinding Mill with the help of Electric Power**





#### **PART-D**

#### **IV. Answer shortly**

- 1) Write the property of Fat lime and their uses.
- 2) What are the types of preparing the lime mortar.
- 3) What are the types of lime & explain.

#### **PART-E**

#### **V. Answer in detail**

- 1) What are the difference between Fat lime and hydraulic lime.
- 2) What are the types of grinding the lime & Explain.

## 4.3 TILES

### 4.3.1. Introduction

The tiles are manufactured like bricks. But the mould differs. The properties of this should be like the properties of bricks.

### 4.3.2 Types of Tiles and Their Uses

The tiles are classified according to their usage as follows:

- 1) Drain tiles
- 2) Floor tiles
- 3) Roof tiles

### 4.3.3 Drain Tiles

Drain tiles are manufactured in such a way that they retain porous holes after burning. If the tiles are used in water logged areas they allow sub soil water to pass through their holes. The drain tiles are circular, semi-circular (or) segmental in shape. These files are used to carry irrigation water. These tiles are used in modern days.

### 4.3.4 Floor Tiles

The floor tiles may be square (or) hexagonal. They are flat and the thickness varies from 12 mm to 50 mm. Square tiles are 150 mm to 300 mm in size.

As the floor tiles are hard and tough they reduces the wear and tear.

Thin floor tiles are embedded for roof ceiling decoration. If colouring agents are used while manufacturing the floor tile we can get coloured floor tiles. Floor tiles may also be fixed in the side walls of bathroom.

### 4.3.5 Roof Tiles

This tiles are used for sloped roof houses. These tiles are used in the villages and called as tiled house. Several roof tiles are used they are

#### 1) Allahabad Tile

These are manufactured from where we get selected Clay. The tiles are moulded by pressing through machine. We can change the tiles manufactured like this to high strength by burning.

While manufacturing itself certain projections are provided in the tiles. This projection helps the interlocking of tiles and they are manufactured according to the necessity such as hip like tiles for hip portion valley like tile for valley portion and ridge like tile for ridge portion. According to the joining of the tiles each other there will be a projection in the side. By using mangalore moulds ridge, hip, chimney portion tiles are designed.

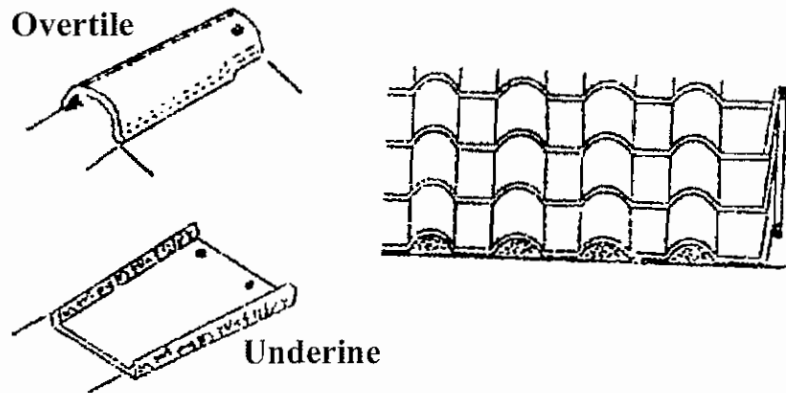

**Fig. 4.3.1. Allahabad Tile**

### 2) Corrugated Tiles

This tiles are like the corrugations. Hence it is called corrugated tiles. When this tiles are placed on the roof it is enough to overlap two corrugations to join each other. These are made by galvanized iron sheets.

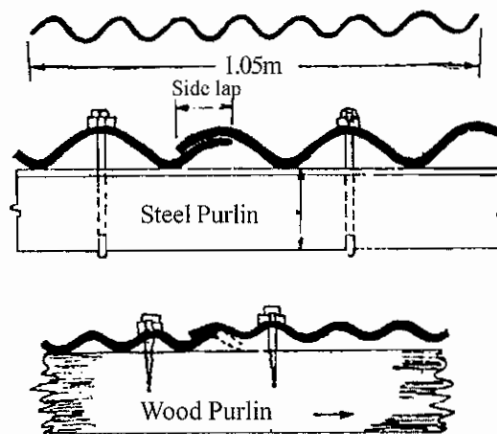

**Fig. 4.3.2. Corrugated Tiles**

### 3) Flat Tiles

These are like ordinary floor tile. These are used to lay on the sides walls of the Bathroom and Kitchen.

### 4) Flemish Tiles

These tiles are moulded by English letter 'S' like mould.

### 5) Mangalore Tiles

To drain the water the red colour mangalore tiles are moulded with two channel like structure . According to the joining of the tiles each other there will be a projection in the side of tiles. By using mangalore moulds ridge, hip, chimney portion tiles are designed.

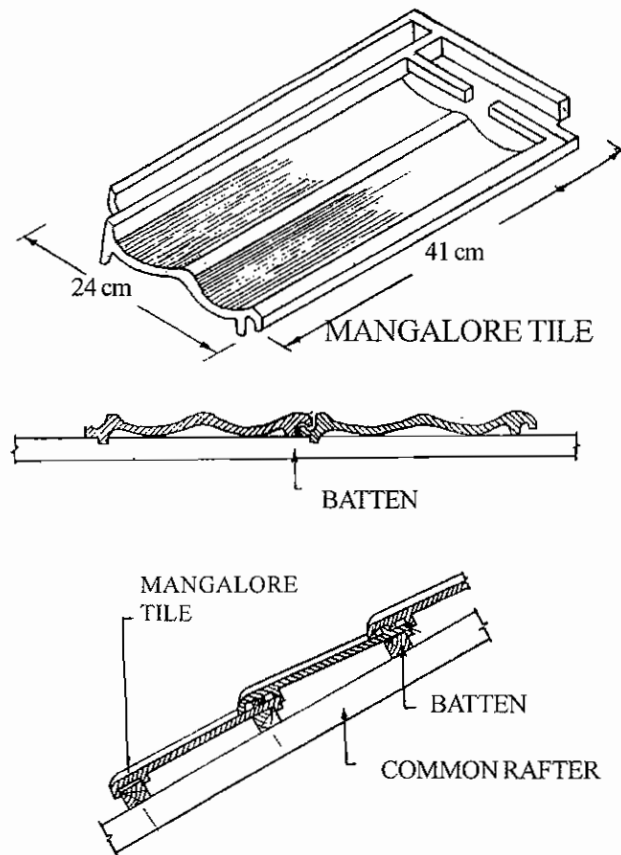

**Fig. 4.3.3. Mangalore Tiles**

As this tiles are coming from mangalore of KARNATAKA state to TAMILNADU these are called as Magalore tiles. This tiles are also manufactured in cochin, Calicut of KERALA state. Maximum 24% of water can be absorbed by "A" class tiles.

**6) Pan Tiles**

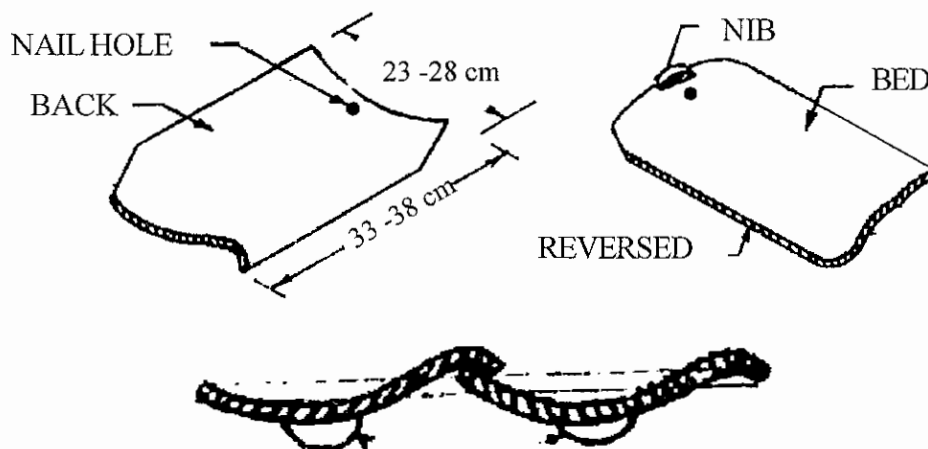

**Fig. 4.3.4. Pan Tiles**

These are small & hard. When compared to pot tiles they have minimum undulations. Good quality are manufactured by molding, drying, burning. The length in 33cm to 38cm. The breadth in 23cm to 28cm.

#### 7) Pot Tiles

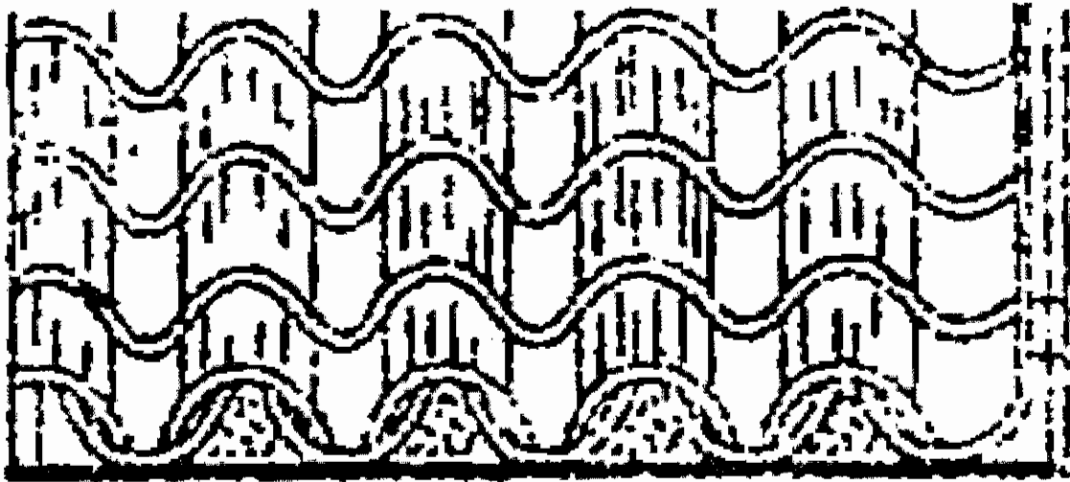

Fig. 4.3.5. Pot Tiles

These are ordinary semi-circular country tiles. As this tiles are made by pot makers hence they are called pot tiles. This tiles are small handy and comfort to handle. So Tamil people are calling this as hand tiles. These tiles are easily breakable.

## QUESTIONS

### PART-A

#### I. Choose the best answer

- 1) The suitable structure of tile to drain rain water.  
a) Mangalore tiles      b) corrugated tile      c) Flemish tile      d) Flat tile.
- 2) Length (cm) of Pan tile.  
a) 33 to 38      b) 23 to 28      c) 12 to 50      d) 18 to 26
- 3) Semi-circular shaped tile  
a) Pot tile      b) Pan tile      c) corrugated tile      d) Flemish tile.

### PART-B

#### II. Answer in one (or) two words

- 1) Which is the tile takes water for irrigation.
- 2) What is the maximum percentage of water absorption capacity for Mangalore tile.
- 3) What is the other name of Pot tile.

### PART-C

#### III. Answer in one (or) two sentences

- 1) What are the types of tiles.
- 2) What are the types of Roof tiles.

### PART-D

#### IV. Answer Shortly

- 1) What are the types of roof tiles and explain.

### PART-E

#### V. Answer in detail

- 1) What are the types of tiles and explain their uses.

# UNIT – V

## BUILDING CONSTRUCTION

### 5.1 FOUNDATION

#### 5.1.1. INTRODUCTION

Every building has two important parts. The one part is below the ground level and another part above the ground level. The structure constructed below the ground level to transmit the total load of the structure above the ground level safely to the earth is called foundation.

#### 5.1.2. Object

- 1) Foundations are constructed to avoid the spreading of total load of building structure to a particular area and to allow the uniform spreading to a larger area.
- 2) The foundations gives stability, strength and protection from wind, storm and rain.
- 3) The foundation gives uniform and equal area for the construction above the ground level.

#### 5.1.3. Types of Foundation

- 1) Shallow foundation
- 2) Deep foundation.

#### 5.1.4. Shallow Foundation

The foundations are constructed in ordinary buildings with low depth. Ordinarily upto 5 m depth are provided. Foundations are the following types.

#### Types of Shallow Foundation

- 1) Wall foundation
- 2) Isolated footing
- 3) Combined footing
- 4) Continuous footing
- 5) Inverted arch footing
- 6) Strap footing
- 7) Grillage foundation
- 8) Raft foundation.

## 1) Wall Foundation (or) Spread Footing

The bottom portion of the wall is formed in similar bottom (or) stepped bottom. The bottom portion is formed with concrete (or) formed with the same materials that are used for wall construction. Atleast two times breadth of the wall base width should be the foundation.

The depth should be minimum of the distance between width of the wall to width of foundation. The concrete ratio used for foundation may be 1:3:6 (or) 1:4:8. Above this stepped brick work are formed.

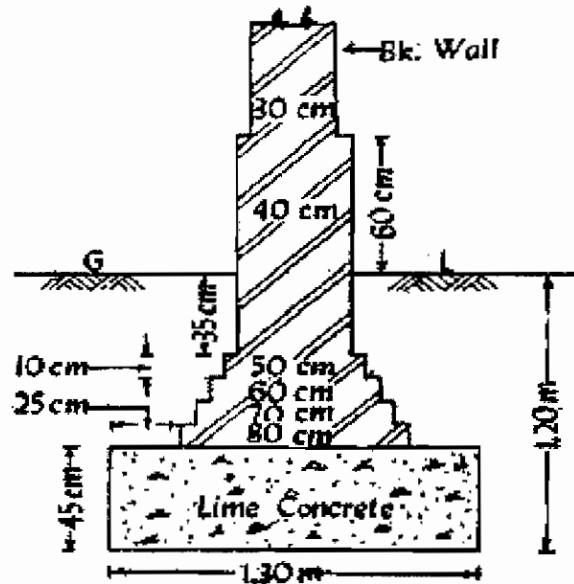

**Details of wall foundation**

**Fig. 5.1.1. Spread Footing Foundation**

### Method of Designing the Breadth and Depth of wall foundation.

- 1) Breadth of foundation = 
$$\frac{\text{Total load / m}}{\text{Allowable bearing capacity of soil}}$$
- 2) Depth of foundation is designed by Rankinds formula = 
$$d = \frac{p}{r} \times \left[ \frac{1 - \sin \theta}{1 + \sin \theta} \right]$$
  - P = Total load acting on the foundation
  - r = Density of soil
  - $\theta$  = Angle of soil

## 2) Isolated Footing

These foundations are formed for individual concrete (or) Brick Pillar. The base structure are formed in stepped (or) slopped position. Reinforced concrete foundations are formed while forming the foundation for heavy weight pillars.



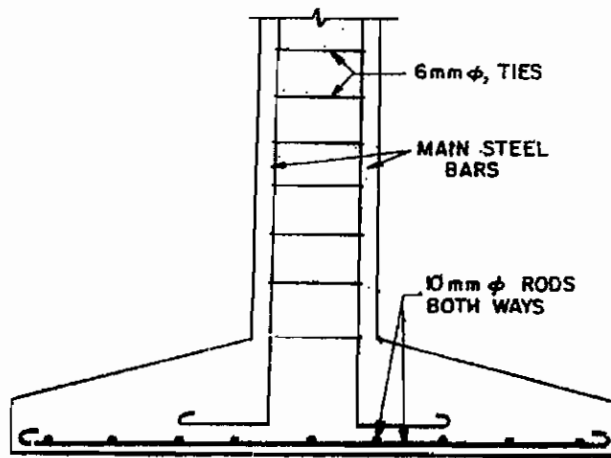

Fig. 5.1.2. Isolated Footing

### 3) Combined Footing

A combined footing supports two or more columns in a row. The combined footing can be rectangle in shape both column carry equal loads. The location of centre of gravity of column loads and the centroid of the footing should coincide.

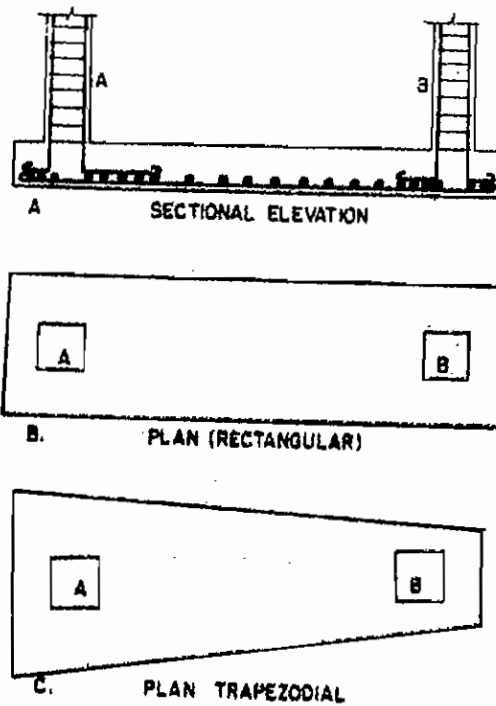

Fig. 5.1.3. Combined Footing

#### 4) Continuous Footing

In this type of footing a single continuous RC slab is provided as foundation of two or more columns in a row. This type of footing is best where earthquake is liable to act. This footing prevents unequal settlement. Some times deeper beam is provided between the columns.

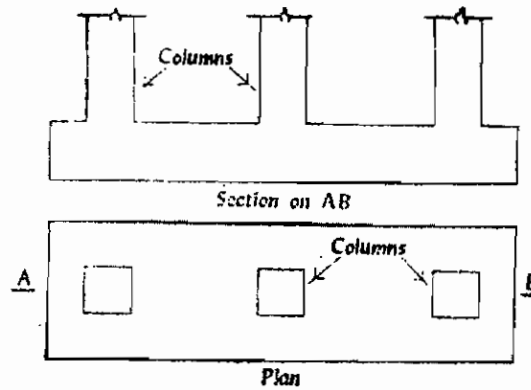
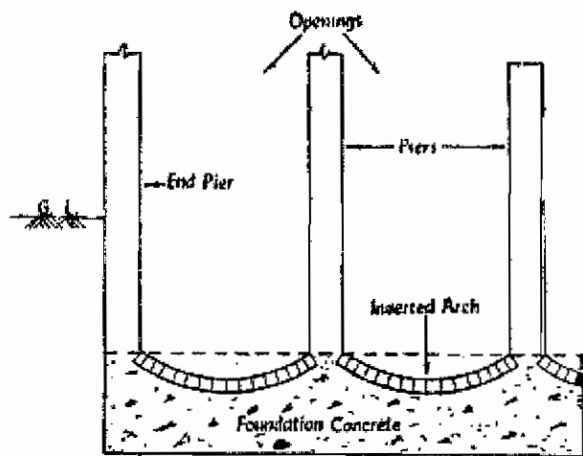

Fig. 5.1.4. Continuous Footing

#### 5) Inverted Arch Footing

While forming the foundation in soft and fine soil these footings are used to reduce the depth of foundation. Through the Inverted arch the whole load acting are transferred by spreading. Mostly these are used for Bridges. As it is curve in shape it bears heavy load due to its arch action.  $\frac{1}{2}$  Brick (or) Concrete is used to form this arch.



Inverted arch foundation

Fig. 5.1.5. Inverted Arch Footing

#### 6) Strap Footing

Strap footing consists of two (or) more individual footings connected by a RC beam. These beams are called strap beams. This type of footing may be used where the distance between the columns is so great.

## 7) Grillage Foundation

These foundations are used to transmit heavy loads from steel column to the soils having low bearing power. The fig. of grillage foundation is shown in fig. We can avoid high digging of soil by using this foundation. At the same time we can get large area to spread heavy load to the earth.

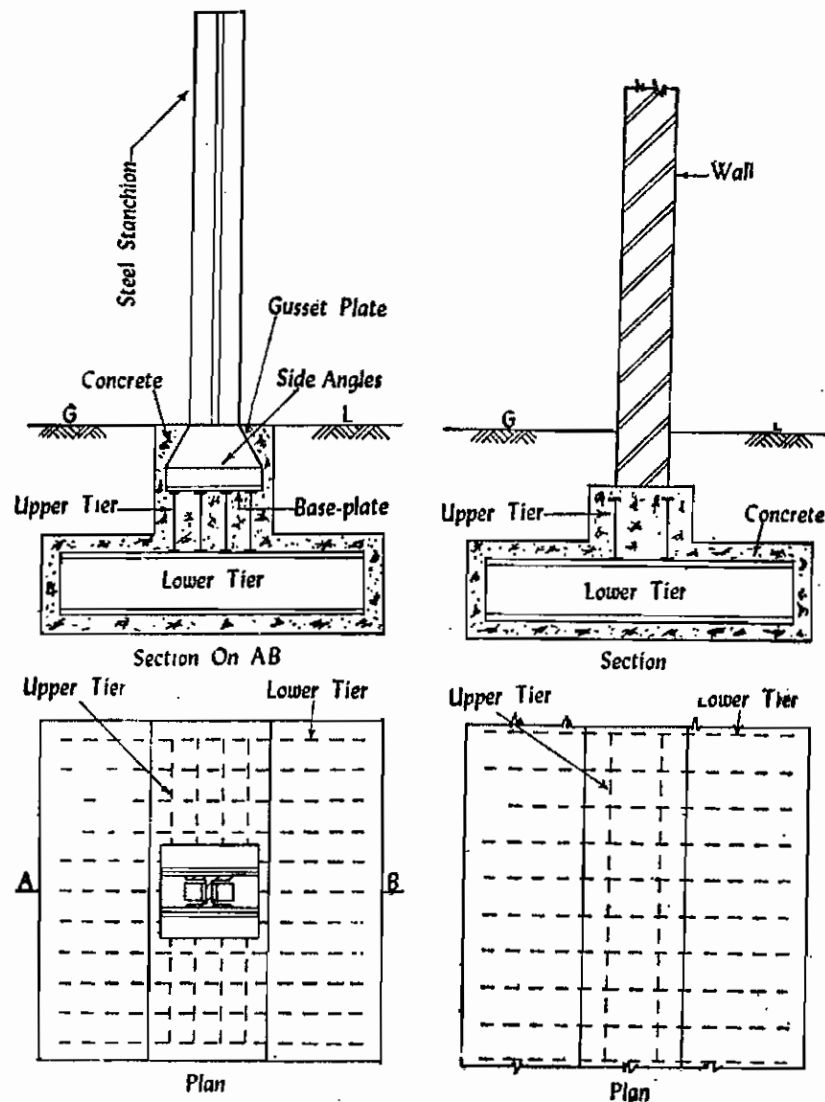
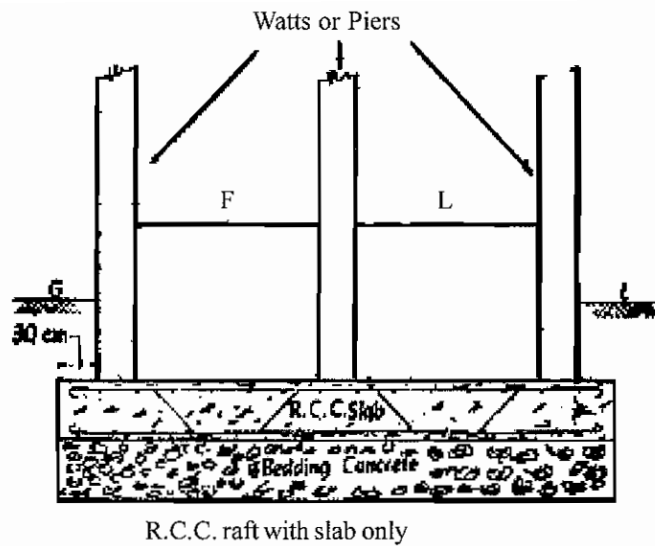

**Fig. 5.1.6. Grillage Foundation**

Small steel columns are in lower level and steel beams are constructed to top layer in vertical direction. Above that Steel column is formed by fixing base plate. Angle Guesst plate are used to connect the steel column and base plate. These beams and pillar are hidden by filling concrete.

## 8) Raft Foundation

A Raft (or) mat is a combined footing that covers the entire area beneath a structure and supports all the columns. The Raft foundation is economical when constructing the isolated footing. The total area of it should be more than the building area.



**Fig. 5.1.7. Raft Foundation**

These foundations are economical when there is clay below the ground. When load of the building is heavy & low bearing capacity of soil.

### 5.1.5 Deep Foundation

These foundations are suitable when building are constructed in low bearing capacity of soil (or) hard rock is only available in high depth.

It is classified in two types.

- 1) Pile Foundation
- 2) Well foundation

#### 1) Pile Foundation

#### NECESSITY OF PILE FOUNDATION

- 1) These are useful When the load is heavy in the building and it is not possible to transmit the load uniformly to ground.
- 2) These are useful where water level raise and falls in ground.
- 3) When it is not easy to pump the stagnated water in foundation these type are useful.
- 4) This is an alternative for Raft and Grillage foundation. Also construction of the above two foundation is costly & also it is tough.
- 5) This foundation is useful for depth 20 m to 30 m.
- 6) In other type of foundation digging and timber supporting is costly and tough, hence we can follow this type.
- 7) These are suitable for constructing building in the banks of Drains and Channels.
- 8) These are also constructed in seashore and banks of river where erosion occurs.
- 9) Pile foundation acts like anchor, so it is suitable where sliding force and vertical force acts.

## 2) Well Foundation (or) Caisson Foundation

The foundation structure constructed under water and sandy areas is called Caisson

These are three types.

- 1) Box Caisson
- 2) Open Caisson
- 3) Pneumatic caisson.

### 1) Box Caisson

Box caisson are used where hard rock is available at lower depth. Caisson is a strong water tight vessel open at top and close at bottom.

### 2) Open Caisson (or) Wells

The open caisson is a well which is open at top and bottom. These foundations are constructed in the ground where high erosive sand and soft bearing stratum occurs. These are constructed in the shape of square, Rectangle and Circle.

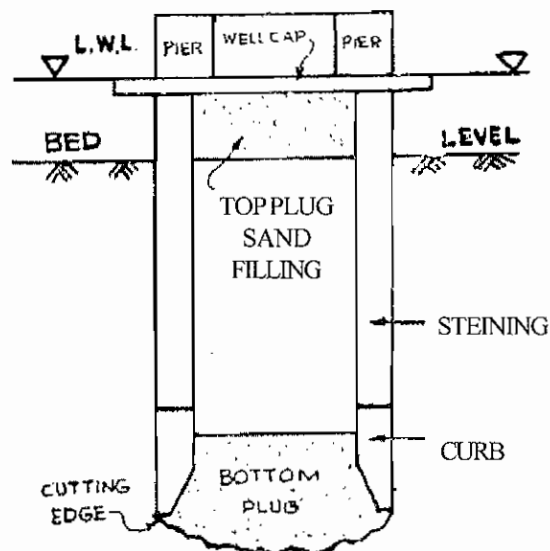

Fig. 5.1.8. Open Caisson

### 3) Pneumatic Caisson

In this type of foundation bottom portion is open and top portion is closed. We can use this when digging well is not possible. These are constructed when availability of water level is at 12 m from ground.

### 5.1.6. Foundations Constructed in Black Cotton Soil

Black cotton soil has got useless property. This type of soil expands when moisture rises. when moisture reduces it shrinks . According to the variations of temperature shrinkage and expansions occurs alternatively. Due to the weight of the building structure it immerse in the ground because of shrinkage of soil.

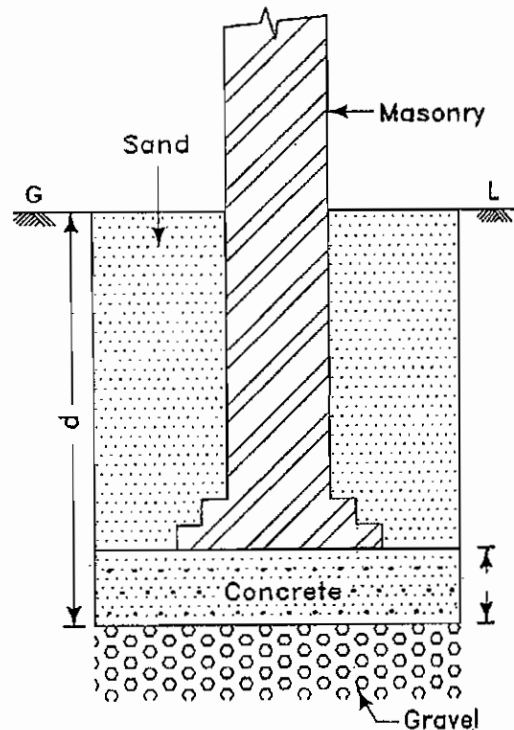

**Fig. 5.1.9. Foundations Constructed in Black Cotton Soil**

#### **POINTS TO BE NOTED WHEN FOUNDATIONS ARE CONSTRUCTED IN BLACK COTTON SOIL**

- 1) It depth of the black cotton soil is less than 1 m it can be digged and removed and other hard soil is filled in that place.
- 2) It should be noted that the depth of foundation should be below the depth of black soil.
- 3) In order to prevent the force acting on the soil the load of building should not exceed  $5000 \text{ N/m}^2$ .
- 4) To resist the longitudinal force acting on the foundation RCC can be used. While providing this concrete a layer of sand should be filled between the layers of concrete and black soil.
- 5) It is an alternative for Raft foundation, Pile foundation and grillage foundation.
- 6) Under reamed pile with concave base is the best option for this type of soil.

#### **Under Reamed Piles with Concave Base**

These foundations are the best for the black soil regions. As shown in the figure one or two more shell like concave base are in these types of piles. These type of shells increases the bearing capacity of

soil. Diameter of pile is 20 cm and diameter of shell is approximately 50 cm are made for these type of piles. These types of piles are useful for the sandy regions and high water level regions.

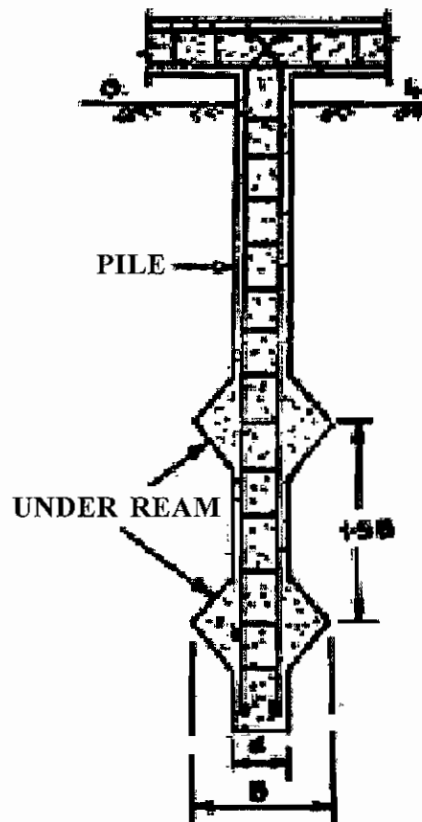

**Fig. 5.1.10. Under Reamed Piles with Concave Base**

#### **5.1.7. Setting out of Work**

- 1) The land where the building is to be constructed should be uniformly made plain.
- 2) Dimension of the hall we are going to construct is 4.8 m x 3.3 m
- 3) As shown in the fig, centre line sketch should be prepared.
- 4) Wall thickness is 0.2 m, So centerline dimension is 5.0 m x 3.5 m.
- 5) As shown in the fig, the points (1) & (2) are driven with steel pegs and stings are tied.
- 6) Making  $90^\circ$  @ the point of 'b' with the help of sets square and strings are tied at point 3 & 4.
- 7) Make the length BC as 3.5 m and steel peg is driven parallel to points 5,6 and A, B.
- 8) Make the length AB, CD as 5 m and steel peg is driven parallel to points bc and 7, 8.
- 9) Now the land area is ready for excavating the foundation.

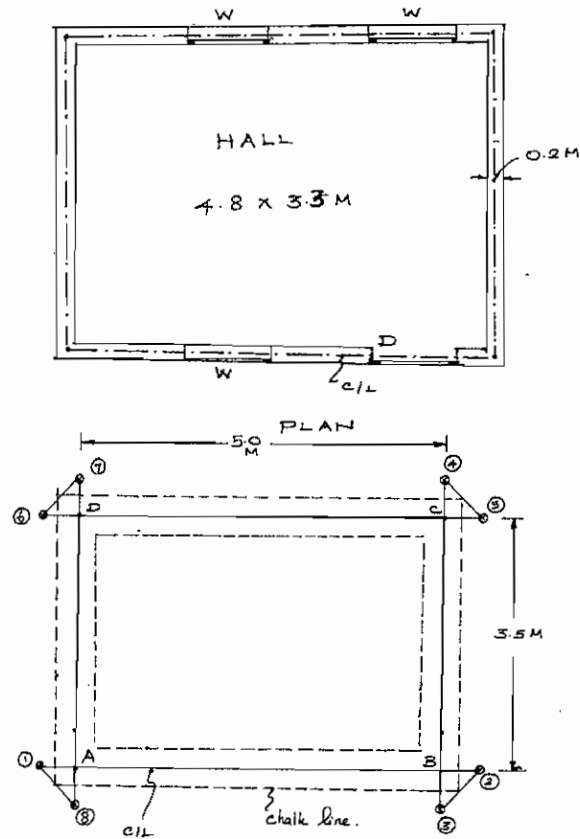

**Fig. 5.1.11. Setting out of Work**

### Check

Diagonal  $AC = BC$  should be checked after completing the marking.

### 5.1.8. Causes of Failure of Foundation and their Remedies

#### Reasons for the Failure of Foundation

- 1) Unequal settlement of soil inside the ground.
- 2) Unequal settlement of walls and parts of the building.
- 3) Withdrawal of moisture content of soil in the foundation area.
- 4) Lateral pressure of the structure above the ground level.
- 5) Horizontal pressure of the earth.
- 6) Spreading of the root of tree.
- 7) Changes of atmosphere conditions.

#### 1. Unequal Settlement of The Sub Soil

When the load of all the parts of building is not even the unequal settlement occurs low where the load is low and high where the load is high. Because the bearing capacity of soil is not uniform in all the



places. So cracks are formed in the building due to the variations in the settlement of soil inside the earth.

#### **Method of Prevention**

- 1) Foundations should rest on hard rock (or) hard moorum.
- 2) Type and design of foundation should be selected according to the nature of soil.
- 3) It should be seen that the allowable bearing capacity of the soil should not exceed in future.

### **2. Unequal Settlement of the Masonry**

The mortar joints in the wall and other building portion may shrink and this may lead to unequal settlement of the building portion.

#### **Method of Prevention**

- 1) The water used to mix the cement mortar for the construction of building should be in correct proportion and it should not exceed.
- 2) Height of raising the super structure should be uniform. Height of the constructing wall should not exceed 1.5 m / day.
- 3) Curing of the masonry should be more.

### **3. Withdrawal of moisture from the sub soil**

Failure of foundation occurs where there is variation in the height of water table. The cracks are formed when the soil shrink due to the sudden reduction of water table from top to bottom.

#### **Method of Prevention**

The foundations are provided by inserting the piles to the extreme end where the availability of hard rock.

### **4. Lateral pressure on the superstructure**

The walls of foundations are liable to fall when sloped roof (or) Arches are constructed (or) due to the wind force.

#### **Method of Prevention**

The base of the foundation wall should be much wider.

### **5. Horizontal movement of the earth**

When buildings are constructed in the low level area and river bed where the soil is loose the foundation may fail due to the horizontal movement of earth.

#### **Method of Prevention**

To avoid sliding of soil bearing walls (or) Pillar with plates may be constructed.

## **6. Transpiration of trees and shrubs**

The moisture content of soil is absorbed by the penetration of roots from the trees and plants around the foundation of the building. So cracks are formed to the shrinkage of soil.

### **Method of Prevention**

- 1) The foundations are taken sufficiently deep that is the foundation should be beyond the roots of tree. Minimum depth should be one meter.
- 2) It should be seen that the fast growing trees and trees requiring more water should be 8 m away from the building.

## **7. Atmospheric Action**

The important factors affecting the foundation are rain and sun.

Chemical reactions and adverse effects are happening when the chemical substances in the rain water entering the earth.

### **Method of Prevention**

- 1) Foundation should be deep up to which rain water can reach.
- 2) After the masonry works are finished sides of wall should be filled with earth and consolidated well. Rain water should be drained properly and it should not stagnate near the walls.

## QUESTIONS

### PART-A

#### I. Choose the best answer

- 1) Concrete ratio followed for foundation.  
a) 1:3:6                      b) 1:4:6                      c) 1:2:4                      d) 1:4:8
- 2) The foundation provided to protect from Earthquake.  
a) Continuous footing                      b) combined footing  
c) Wall footing                      d) Pile foundation.
- 3) Foundations provided for constructing the bridges  
a) Spread footing                      b) Inverted footing  
c) Pile foundation                      d) continuous footing.
- 4) The foundation provided where the availability of clay layer below ground level.  
a) Spread footing                      b) wall footing  
c) Pile foundation                      d) Inverted footing.

### PART-B

#### II. Answer in one (or) two words

- 1) How can we call the structure constructed below the ground level.
- 2) What is the foundation followed where the bearing capacity of soil is low.
- 3) What type of foundation is provided for the lateral pressure and vertical pressures.
- 4) What is the name of foundation provided under water?

### PART-C

#### III. Answer in one (or) two sentences

- 1) What are the two important parts of the building structure?
- 2) What are the types of foundation.
- 3) What is the aim of providing the foundation.
- 4) Write the Rankine formula to calculate the depth of foundation and write the notation.
- 5) What are the types of caisson foundation.
- 6) What are the reasons for the failure of foundation.

## **PART-D**

### **IV. Answer shortly**

- 1) Write the necessity for the construction of pile foundation.
- 2) What are the points to be noted while foundation are provided in black cotton soil.
- 3) What are the types of well foundation and explain.

## **PART-E**

### **V. Answer in detail**

- 1) What are the types of shallow foundation and explain.
- 2) What are the reasons of failure of foundation? Describe the preventive methods of them.

## 5.2. STONE MASONRY

### 5.2.1. DEFINITION

If construction is carried out using stones with cement or lime mortar, it is known as stone masonry.

It can be divided into following categories.

1. Stone masonry
2. Brick masonry
3. Composite masonry

### 5.2.2. TERMS USED IN STONE MASONRY

#### Natural Bed

The surface on which the materials was originally deposited in the formation of rock is known as natural bed. Rocks from which tones for masonry is obtained have distinct planes of division along with stone can easily be split. These planes are the natural beds of the stone.

#### Bond

The interlocking arrangement of bricks, so as to avoid the occurrence of continuous vertical joints is known as bond.

#### Quoins

The external corner (or) angles of a wall are known as quoins and the stones (or) bricks forming the quoin are known as quoin stones (or) quoin brick.

#### Sill level

The bottom surface of a door (or) a window opening is known as a sill level.

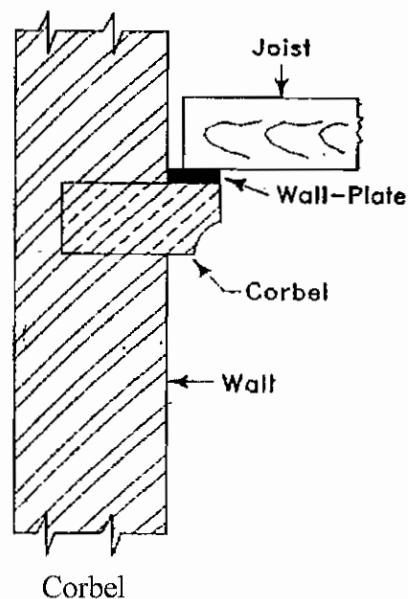

Fig 5.2.1. Terms used in Stone masonry

## Corbel

It is a projection provided on the inside face of the wall by projecting stones. The projection is used to serve as a support for root plates (wooded beam) for roof trusses, beams etc.

## Weathering

It is a term to indicate bevelled top surface of the stone. It is sloped so as to allow easy flow of rain water;

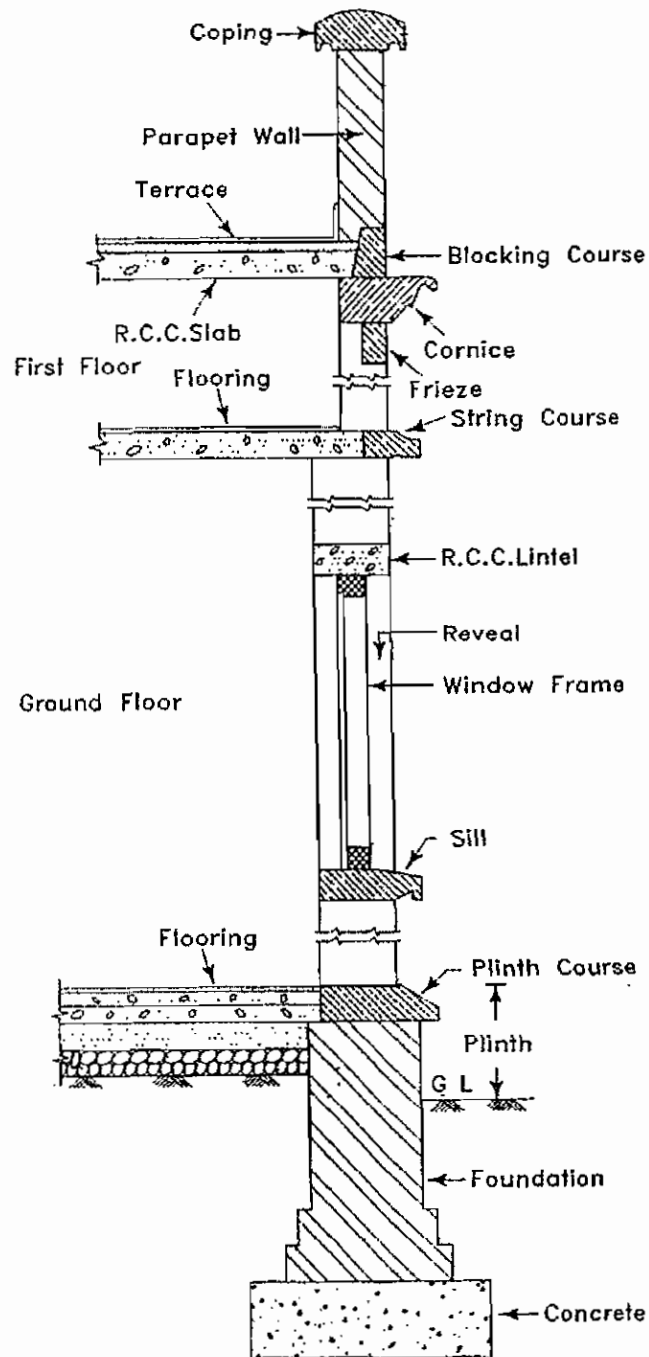

Fig. 5.2.2. Terms used in Stone masonry

### Spalls

Stone chips broken off from large size stone during dressing and shaping are known as spalls.

### Lacing Course

The horizontal course provided to strengthen a wall of regular small stones is known as a lacing course.

### Through Stones

In stone masonry, some stones at regular intervals are placed through the full thickness of wall to develop bond. Such stones are known as through stones.

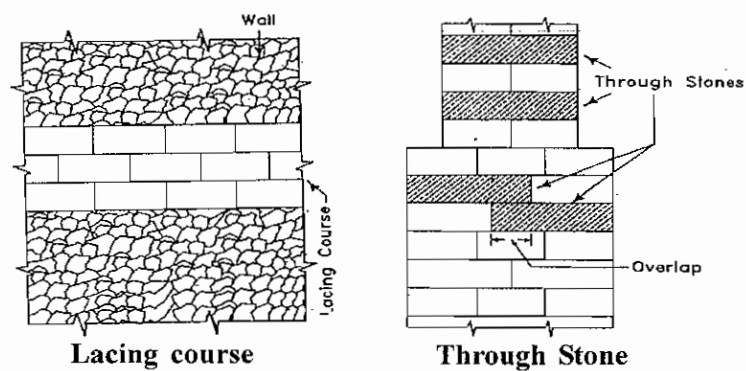

Fig. 5.2.3. Terms used in Stone masonry

### Cornice

This is a moulded course of masonry having large projections. It may be provided at the junction of the wall and ceiling near the top of the building.

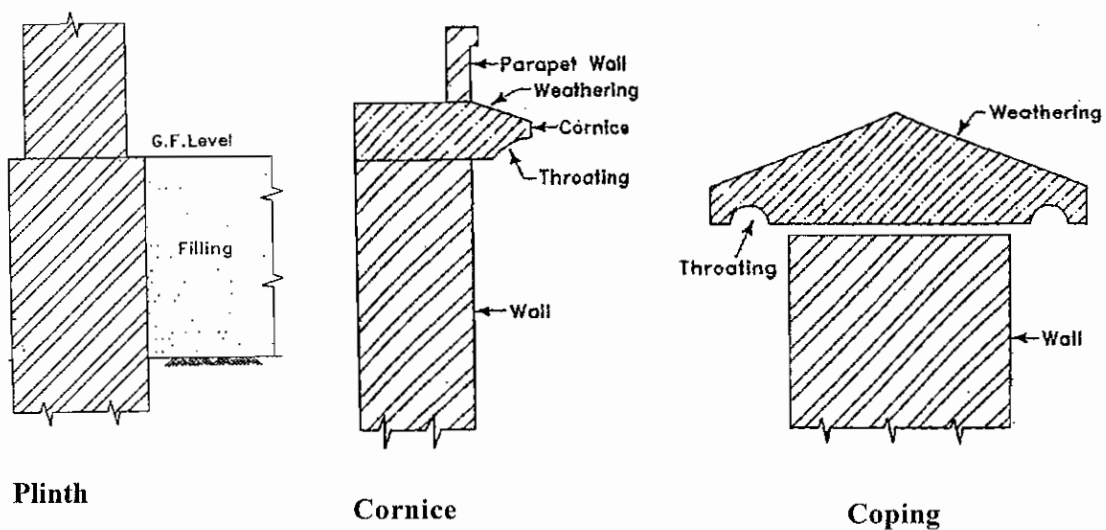

Fig. 5.2.4. Terms used in Stone masonry

## **Coping**

It is a course of stone, concrete (or) bricks provided at the top of the wall so as to protect the wall from seepage of rain water through joints at the top most course of the wall. This course is generally provided at the top of a parapet wall (or) compound wall.

## **Throating**

It is a small groove cut on the underside of sill, coping, cornice and projected chajja to discharge the rainwater without trickling down to the walls.

## **Course**

A layer of stones or bricks is known as a course. The thickness of a course is equal to the thickness of a stone or brick plus thickness of one mortar joint.

## **Plinth**

The projecting course at ground floor level is known as the plinth. It is also used to indicate the height of ground floor level from ground level. The plinth course protects the interior of a building from rain water, frost etc. It is sometimes moulded and given ornamental treatment. The offset at plinth level is sometimes omitted for the architectural purpose.

## **String Course**

It is a continuous horizontal course of masonry, generally provided at every floor level. This course remains projecting from the face of the wall and is intended to improve the elevation of the structure.

### **5.2.3. DRESSING OF STONES**

The process of cutting stones into suitable sizes and shapes is known as dressing of stones.

#### **Objects of Dressing**

1. To convert the stone pieces into desired shape and size.
2. To make thin mortar joints thereby reducing the mortar consumption and to improve the qualities of work.
3. To give the desired surface finish.
4. To make transport easy and economical from quarry.

#### **TYPES OF DRESSING**

1. Hammer dressing
2. Chisel dressing
3. Punched dressing
4. Furrowed dressing
5. Combed dressing



### 1. Hammer Dressing

A hammer dressed stone shall have no sharp and irregular corners and shall have comparatively even surface. All the sharp and irregular corners of the stone obtained by quarrying shall be knocked off by using the flat face of a scrabbling hammer. The surface shall be dressed with the pointed end of the hammer.

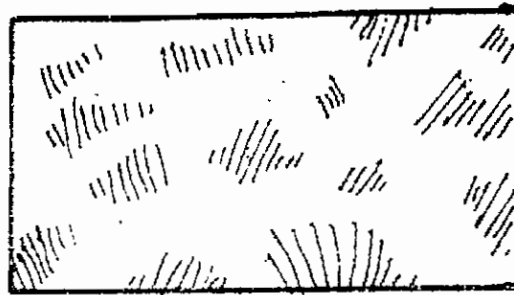

Fig. 5.2.5. Hammer Dressing

The projection on the face shall not be more than 40mm on an exposed face.

### 2. Chisel Dressing

Stones available from the quarry is first dressed with hammer and then smoothly dressed by means of a pointed chisel, so that all the projections are removed and a fairly smooth surface is obtained. In this type of dressing the depth of gap between the surface and a straight edge kept over the surface shall not exceed 1.5mm. This type of dressing is very commonly adopted for ashlar work.

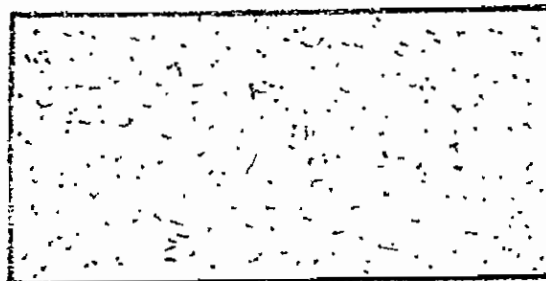

Fig. 5.2.6. Chisel Dressing

### 3. Punched Dressing

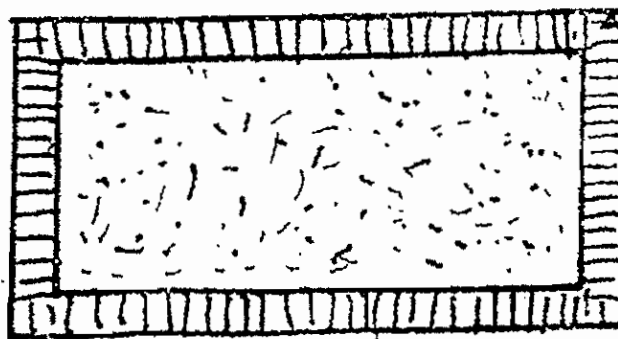

Fig. 5.2.7. Punched Dressing

This is another form of rough dressing usually used for lower portions of the buildings. The exposed face of the stone is dressed with the help of a punch, thus making depressions or punch hole on it at some regular distance (say 25mm) apart. A 25mm wide strip is made around the perimeter of the stone with the help of chisel.

#### 4. Furrowed Dressing

This type of finish is applied to the fillets or flat blands of cornices, string courses, doors and windows etc. After boasting the surface and then rubbing it 6 to 10 mm wide flutes are formed by a gauge. A margin of about 20 mm width is sunk on all the edges of the stones and the central portion is made to project about 15 mm.

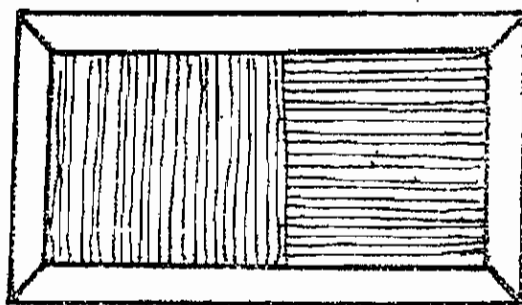

Fig. 5.2.8. Furrowed Dressing

#### 5. Combed Dressing

This finish is used only in soft stones. Drags made of steel plates and of different grades are then dragged backward and forward in different directions until the tool marks are eliminated. Fine drags is used at the end, eliminates all the scratches on the stone.

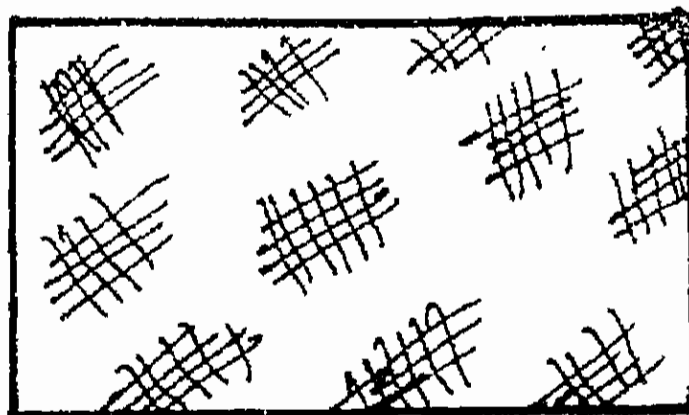

Fig. 5.2.9. Combed Dressing

#### 5.2.4. CLASSIFICATION OF STONE MASONRY

The stone masonry classified as given below.

## 1. Rubble masonry

## 2. Ashlar masonry

### 5.2.5. RUBBLE MASONRY

In this masonry, stones are not dressed finely. They are used in the masonry as they are available from the quarry (or) stones obtained from quarry may be shaped with the help hammers just by removing excess projection before they are used in the masonry.

Types of Rubble masonry

- a Coursed rubble masonry
- b Uncoursed rubble masonry
- c Random rubble masonry
- d Dry rubble masonry

#### A. Coursed Rubble Masonry

In this type of rubble masonry, the height of stones vary from 50 mm to 20 cm. The stones are sorted out before the work starts.

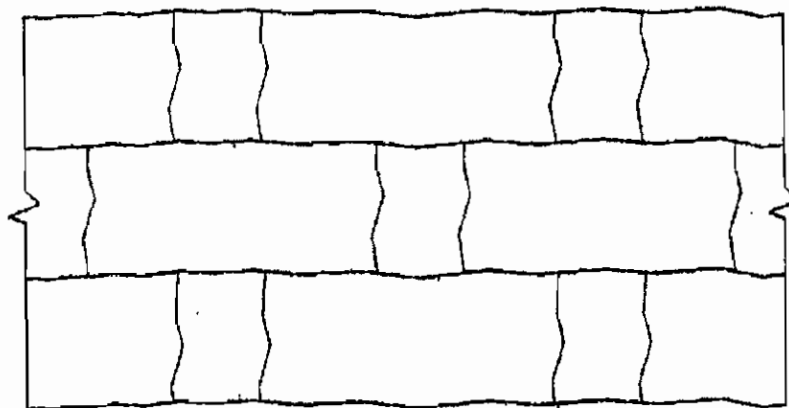
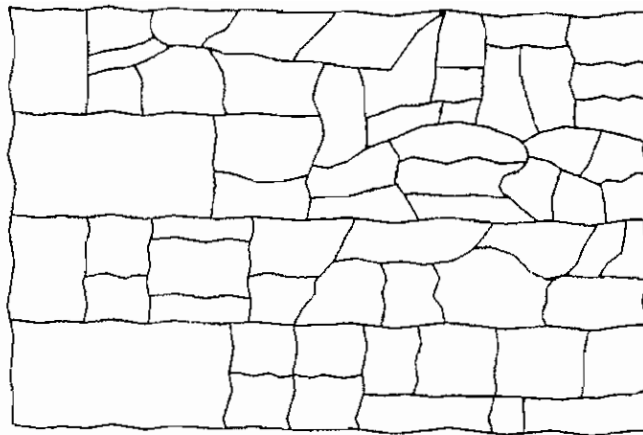

**Fig. 5.2.10. Coursed Rubble Masonry**

The masonry work is then carried out in courses such that stones in a particular course are of equal heights. This type of masonry is used for the construction of public buildings, residential buildings etc.

#### B. Uncoursed Rubble Masonry

In this type of rubble masonry the stones are not dressed. But they are used as they are available from the quarry, except breaking some corners. The courses are not maintained regularly. The larger stones are laid first and the spaces between them are then filled up by means of spalls. The wall is brought to a level every 30 cm to 50 cm. This type of rubble masonry being cheaper, is used for the construction of compound walls, godowns, garages, labour quarters etc.



**Fig. 5.2.11. Uncoursed Rubble Masonry**

**C. Random Rubble Masonry**

The stones of irregular sizes and shapes are used for the construction of masonry. The stones are arranged so as to have a good appearance. More skill is required to make this masonry structurally stable. This face stones are chisel dressed and the mortar joints does not exceed 6 mm to 12 mm. This type of masonry is used for the construction of residential buildings, compound walls etc.

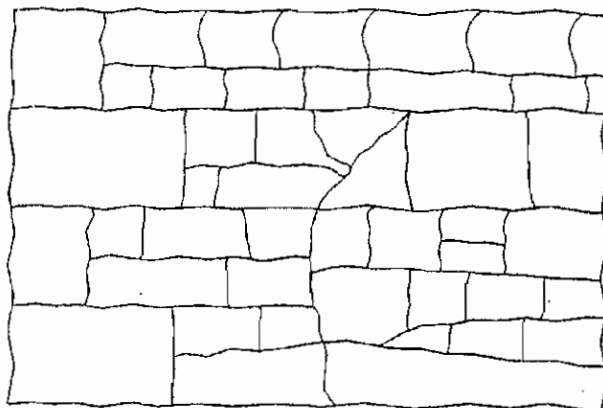

**Fig. 5.2.12. Random Rubble Masonry**

**D. Dry Rubble Masonry**

This is similar in construction of the coursed rubble masonry, except that no mortar is used in the joints. This requires skill in construction. This type of masonry is used in compound walls, pitching, bridge approaches, retaining walls etc.

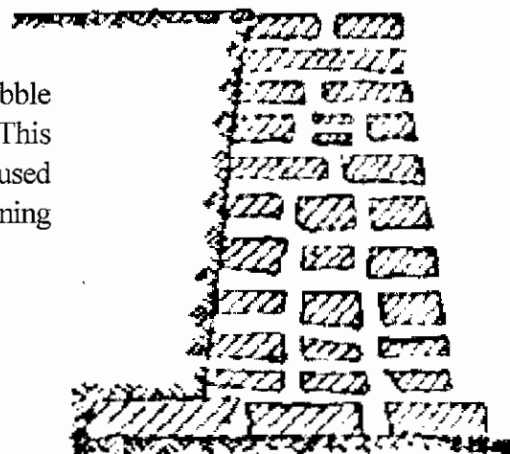

**Fig. 5.2.13. Dry Rubble Masonry**

### 5.2.6. Ashlar Masonry

In this masonry the entire construction is done using square or rectangular dressed stones. The stones used in this masonry are all dressed timely which chiseled. The height of stones varies from 25 cm to 30 cm.

#### Types of Ashlar Masonry

- a. Ashlar fine masonry
- b. Ashlar Rough tooled masonry
- c. Ashlar Rock masonry
- d. Ashlar Chamfered masonry
- e. Ashlar block in course masonry

#### A. Ashlar Fine Masonry

In this type of masonry, the beds, sides and faces are finely chisel dressed. The stones are arranged in proper bond and the thickness of the mortar joints does not exceed 3 mm. This type of construction gives perfectly smooth appearance. It is costly in construction.

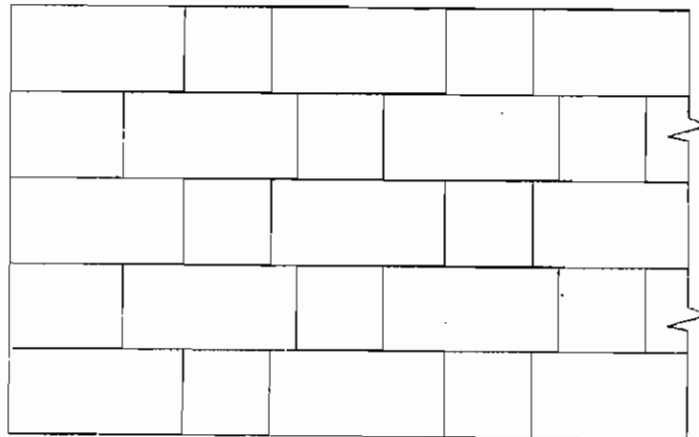

**Fig. 5.2.14. Ashlar Fine Masonry**

#### B. Ashlar Rough tooled masonry

In this type of ashlar masonry, the beds and sides are finely chisel-dressed. But the face is made rough by means of tools. A strip, about 25 mm wide and made by means of a chisel, is provided around the perimeter of every stone exposed for view. The thickness of mortar joints does not exceed 6 mm. This type of work is also known as the bastard ashlar.

#### C. Ashlar Rock masonry

In this type of ashlar masonry, a strip about 25 mm wide and made by means of a chisel, is provided around the perimeter of every stone exposed for view as in case of rough-tooled ashlar. But the remaining portion of the face is left in the same form as received from quarry. Only projections on

the face, known as the bushings, exceeding 80 mm are removed by a hammer. This type of construction gives massive appearance.

#### **D. Ashlar Chamfered**

In this masonry, 2.5 cm chisel, drafting around the face is leveled at an angle of  $45^\circ$  with the help of chisel. Another chisel drafting about 10mm to 12 mm wide is again developed around the perimeter inside the chamfered drafting. The remaining enclosed space is left as such. However, projections of more than 8 cm are removed with the help of hammer.

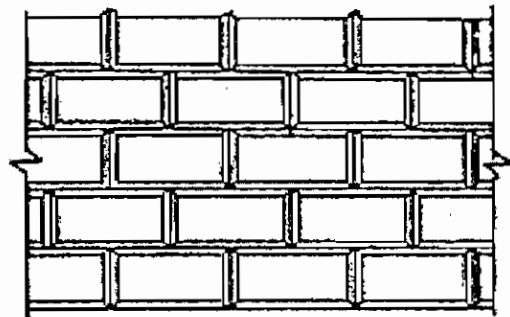

**Fig. 5.2.15. Ashlar Chamfered**

#### **E. Ashlar Facing or Ashlar Block-in-course**

This masonry may be called as combination of rubble masonry and ashlar masonry. The faces of the stones are generally hammer dressed and the thickness of mortar joints does not exceed 6mm. The depth of courses varies from 20 cm to 30 cm. This type of construction may be used for heavy engineering works such as retaining walls and sea-walls.

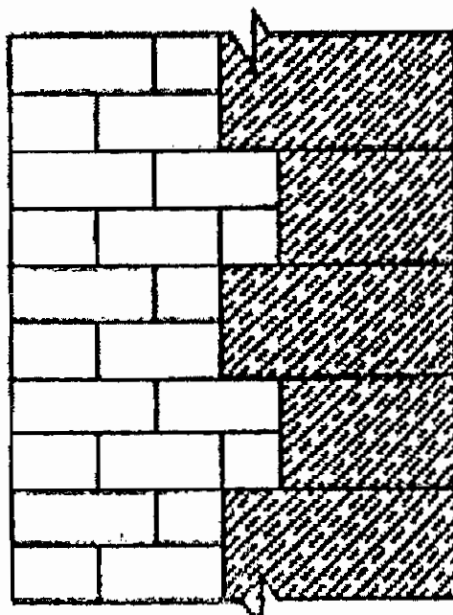

**Fig. 5.2.16. Ashlar Facing or Ashlar Block-in-course**

### 5.2.7. Tools Used in Stone Masonry

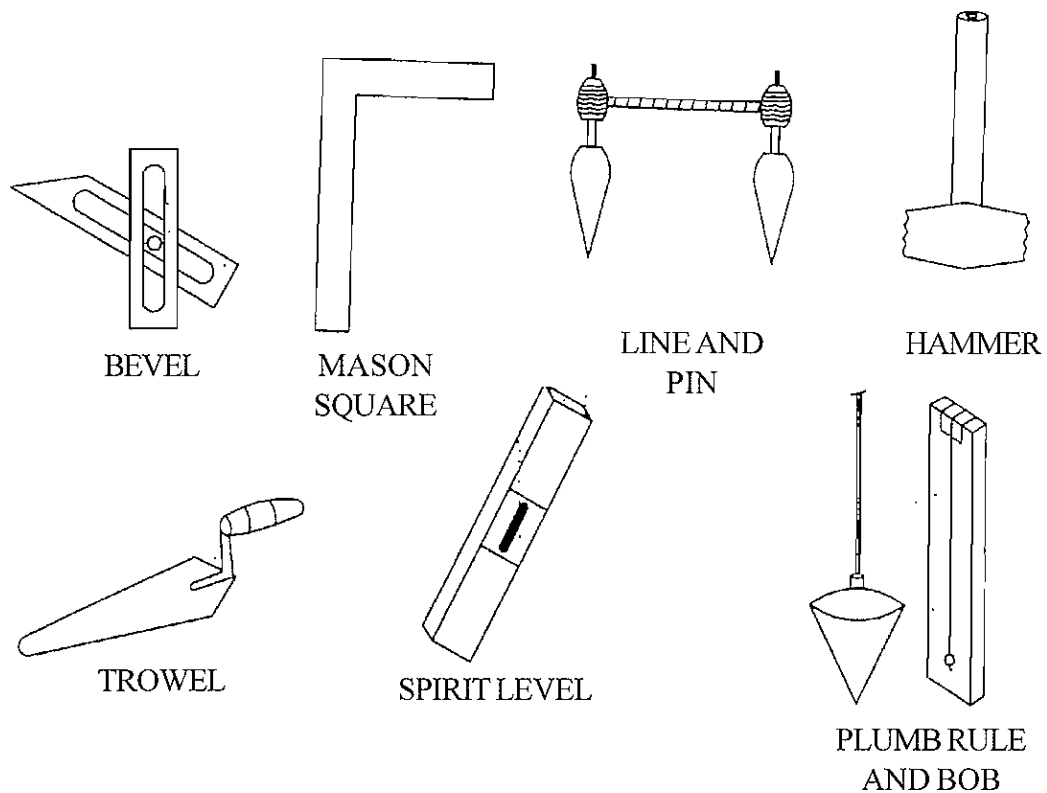

**Fig. 5.2.17. Tools Used in Stone Masonry**

1. Trowel-To lift and spread mortar.
2. Plumb rule and bob - To check the verticality wall.
3. Spirit level - To check the horizontality of the surfaces.
4. Crow bar - To make the stones in quarry.
5. Hammer - For rough dressing of stones.
6. Chisels - To dress stones.
7. Pick axe - For rough dressing and to split stones.
8. Line and pins - To maintain the alignment of the progress.
9. Bevel - To set out angles.

### **5.2.8. Points to be considered in the construction of stone masonry**

1. The stones used should confirm the required specifications.
2. The stones should be well watered before use.
3. All the stones should be laid on the natural bed.
4. The dressing of stones should be properly done.
5. Proper bond with sufficient number of through stones should be provided in construction.
6. No tensile stress should develop in the masonry.
7. Good quality of mortar should be used in construction.
8. Stone work should be raised uniformly.
9. In the stone work, small pieces and chips should not be used.
10. The stone work should be carried out as per line and level.
11. After the construction, the stone work should be watered for the required period.



## QUESTIONS

### PART - A

#### I. CHOOSE THE BEST ANSWER

- 1) In what direction the natural bed of stone is provided.  
a) Slope      b) straight      c) vertical      d) Horizontal
- 2) The name of stone used in outer edges of wall  
a) Sill level    b) Corbel      c) corner stone      d) weathering
- 3) Provision of sill level in the building  
a) Door      b) ventilator      c) Beam      d) Roof
- 4) Layer laid in single row  
a) Plinth      b) Layer      c) coping      d) cornice
- 5) In every floor of building the stone layer laid in each floor.  
a) Weathering      b) sill level      c) Plinth      d) string layer.
- 6) Extension of length when stone dressed by hammer.  
a) 2 cm      b) 5 cm      c) 4 cm      d) 6 cm
- 7) Flat size of external cutting of stone by chisel dressing.  
a) 30 mm    b) 40mm      c) 250 mm      d) 210 mm
- 8) Size of stone used in Random Rubble masonry  
a) 20mm to 50 cm    b) 50 mm to 20 cm    c) 70 mm to 9 cm    d) 10 mm to 20 cm
- 9) Thickness of cement mortar in R.R. Masonry  
a) 6 mm to 12 mm    b) 8 mm to 16 mm    c) 7 mm to 19 mm    d) 4 mm to 8 mm

### PART-B

#### II) ANSWER IN ONE (OR) TWO WORDS:

- 1) Write the types of masonry.
- 2) What is meant by Natural bed?

- 3) What is meant by Plinth?
- 4) What is meant by sill level?
- 5) What are the uses of crow bar?
- 6) What are the uses of hammer?
- 7) Which instrument is used for dressing of stone?
- 8) What is the instrument used for finding vertical position while construction of a wall.
- 9) What is the instrument for finding Angle?
- 10) What is the use of spirit level.
- 11) Define cornice.
- 12) Define plinth and coping.

#### **PART-C**

#### **III) ANSWER IN ONE (OR) TWO SENTENCES:**

- 1) Define Masonry.
- 2) What is meant by stone masonry?
- 3) Define corbel, cornice.
- 4) What is the difference between string coarse and lacing coarse?
- 5) What is the purpose of dressing of stone?
- 6) What are the types of dressing of stone?
- 7) Write 4 materials used in stone masonry.
- 8) What are the types of uncoarsed masonry.

#### **PART-D**

#### **IV) ANSWER SHORTLY:**

- 1) What are the points noted in stone masonry work.
- 2) Define the laying of Dressed stone in uncoarsed Rubble masonry.

- 3) Define the construction of Fine Ashlars masonry with figure.
- 4) Write the material used in stone masonry and define their uses.
- 5) Define the uncoarsed Random Rubble Masonry.

#### **PART-E**

#### **V) ANSWER IN DETAIL:**

- 1) What are the types of dressing of stone? Explain with sketch.
- 2) Define the terms used in stone masonry.
- 3) Write the types of stone masonry and explain uncoarsed masonry work.
- 4) Define the materials used in stone masonry.

## 5.3. BRICK MASONRY

### 5.3.1 INTRODUCTION

Construction of brick units bonded together with cement or lime mortar is termed as brick masonry.

### 5.3.2. Some terms used in Brick masonry

**Stretcher** : It is a full brick which is laid with its length parallel to the face of the wall. If all the bricks are laid as stretchers the course is named as stretcher course.

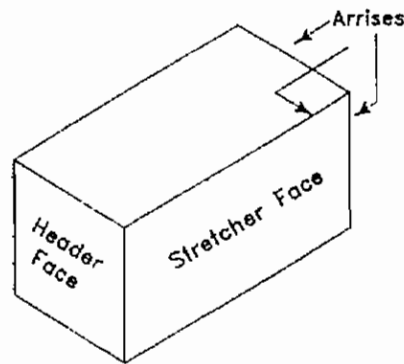

Fig. 5.3.1. Brick stretcher and header

**Header** : It is a full brick which is laid with its length perpendicular to the face of the wall. A course of brickwork entirely composed of headers in header course.

**Bed** : It is a term used to indicate the lower surface of brick in each course.

**Bond** : It is a term applied to the over lapping of bricks in a wall in alternate courses, to bind the whole wall together. Bonding is essential to eliminate continuous vertical joints.

**Closer** : It is a portion of brick cut in such a manner that its one long face remains uncut.

**1. King closer:** It is a brick which is cut in such a way that the width of one of its end is half of that of a full brick.

**2. Queen closer :** It is a term applied to a brick which is half as a full brick. Queen closer is made by cutting a brick lengthwise into two portions.

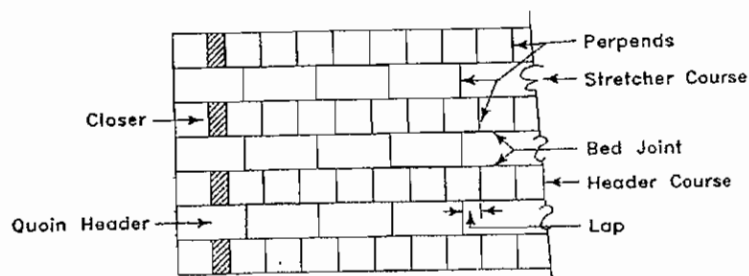
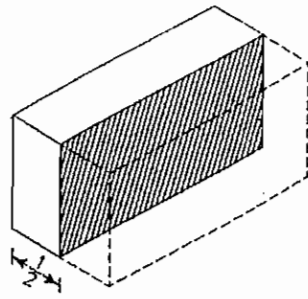
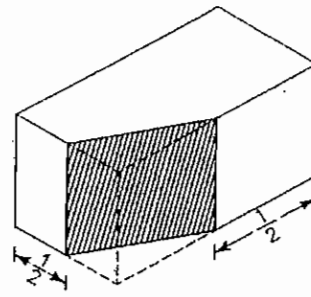

Fig. 5.3.2. Some terms used in Brick masonry



**Queen closer**



**King closer**

**Fig. 5.3.3.**

**3. Beveled closer :** It is similar to king closer the only difference that the whole length of the brick is beveled for maintaining half width at one end and full width at the other.

**4. Mitred closer :** It is a brick whose one end is cut splayed or mitred for the full width.

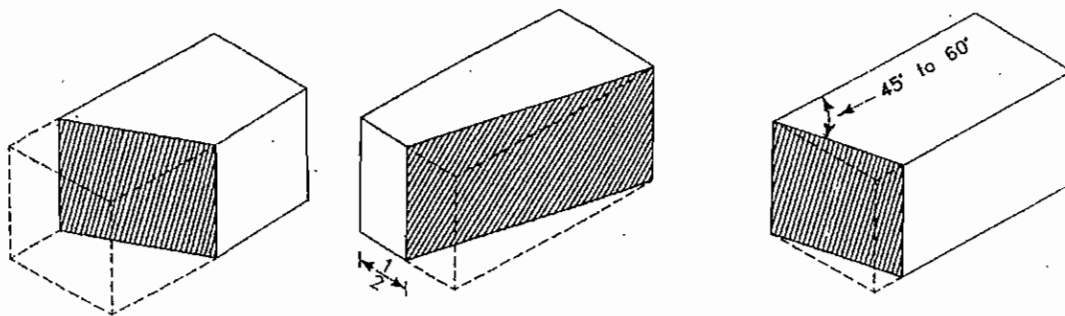

**Beveled closer**

**Mitred closer**

**Fig. 5.3.4.**

**Brick bat :** It is the portion of a brick cut across the width or a brick cut by some fraction of its length. If a brick cut by half size in it called as half bat and cut by three quarter size is three quarter bat.

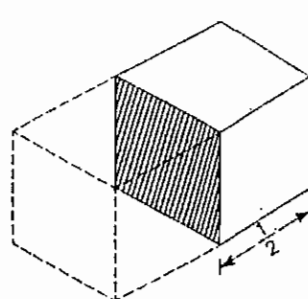

**1/2 Bat**

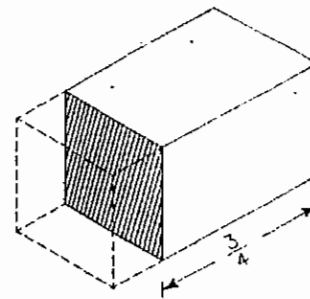

**3/4 Bat**

**Fig. 5.3.5.**

- Lap** : The horizontal distance between two vertical joints is termed as lap.
- Arises** : The edges of the bricks are called as arises. Arises should be sharp and unbroken.
- Bed joint** : Joints parallel to the bed of bricks or stone in a course are termed on bed joints.
- Perpends** : It is a vertical joint on the face of a wall directly over vertical joints of alternate courses.
- Frog** : Depressions provided in the face of the brick is called as frog. It forms a key with mortar to prevent sliding.

### 5.3.3. BONDS IN BRICKWORK

The different types of bonds commonly adopted are given below.

1. Stretcher bond
2. Header bond
3. English bond
4. Flemish bond
5. Garden wall bond
6. Raking bond
7. Dutch bond
8. Brick on edge bond

#### 1. Stretcher bond

In this arrangement of bonding brick work all the bricks are laid as stretchers. It is used for half brick wall only. It is commonly adopted in the cavity walls and partition wall.

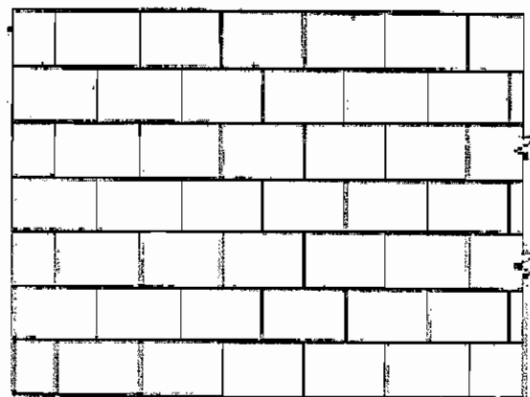

**Fig. 5.3.6. Stretcher bond**

## 2. Header bond

In this type of bonding all the bricks are laid as headers on the face. It is used for walls curved on plan.

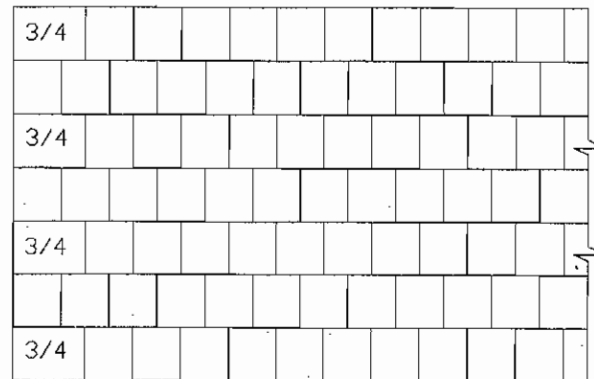

**Fig. 5.3.7. Header bond**

## 3. English bond

This is commonly used bond because it is stronger than the other bonds.

### The important features of English bond

- i) The bond consists of alternate course of headers and stretchers.
- ii) A queen closer will be placed next to the first header in each heading course.
- iii) A course consisting of headers on front face will show headers on the back face also in one brick, two brick, three brick thick walls.
- iv) In walls having their thicknesses equal to an odd number of half bricks. i.e.  $1\frac{1}{2}$ " brick thick walls or  $2\frac{1}{2}$ " brick thick walls and so on the same course will show stretchers on one face and headers on the other.
- v) Continuous vertical joints are eliminated.
- vi) More quantity of cement mortar consumes in header course than stretcher course as far as possible less quantity of cement mortar should be used for header course. Otherwise vertical joint will be formed in next course.

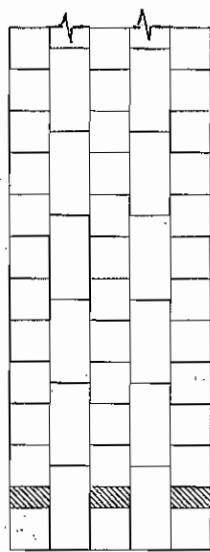

Elevation

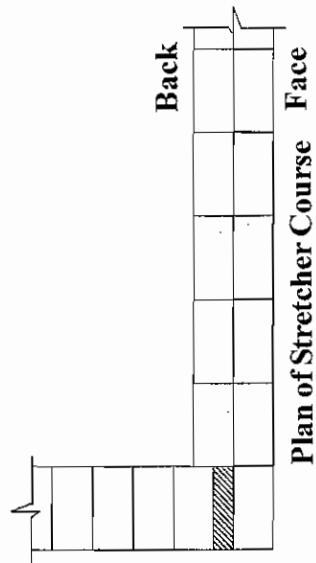

Plan of Stretcher Course

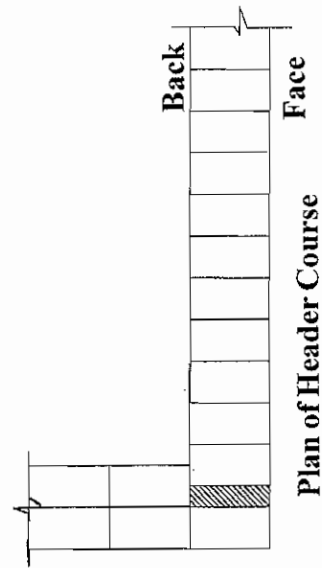

Plan of Header Course

One brick wall

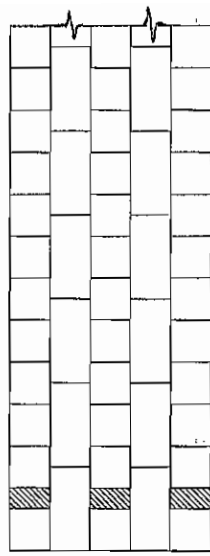

Elevation

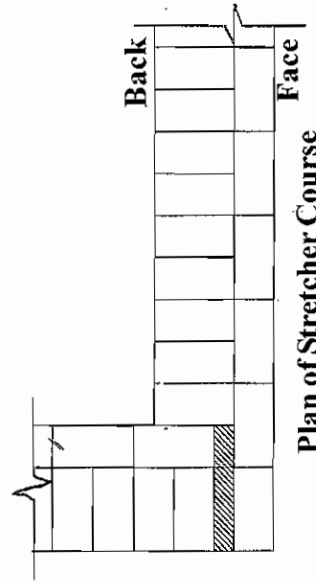

Plan of Stretcher Course

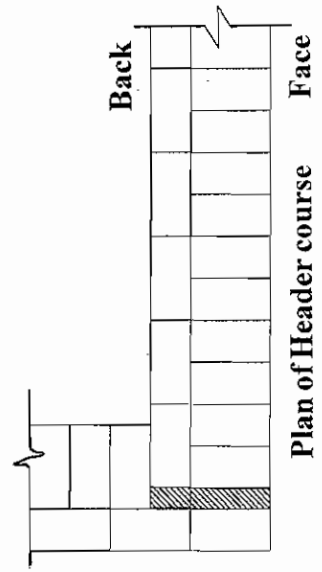

Plan of Header course

One & Half Brick wall

Fig. 5.3.8. English bond (L - Junction)



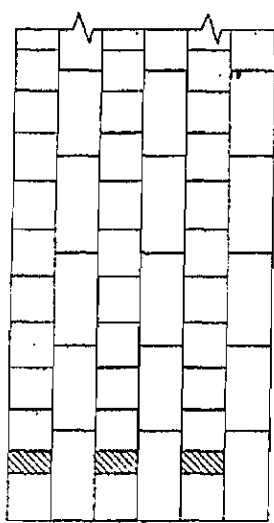

Elevation

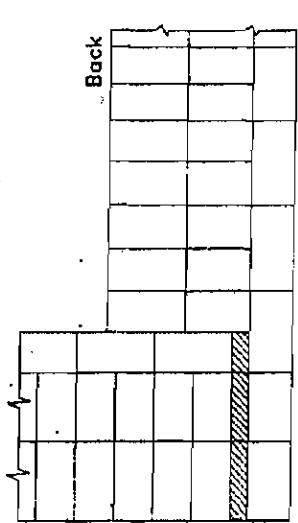

Plan of Stretcher Course

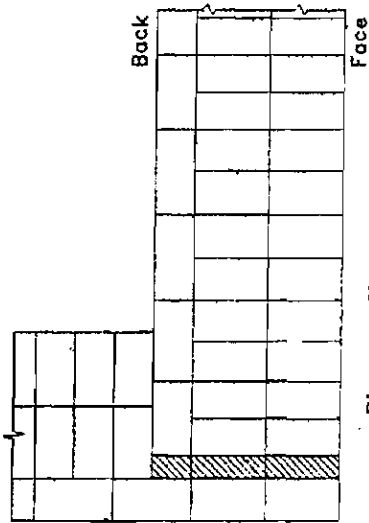

Plan of Header Course

Two & half brick wall

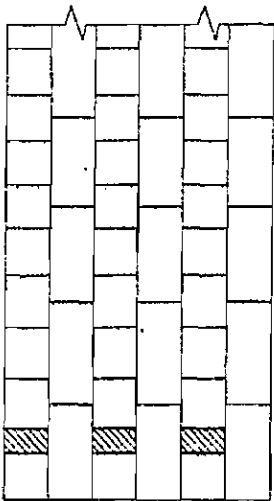

Elevation

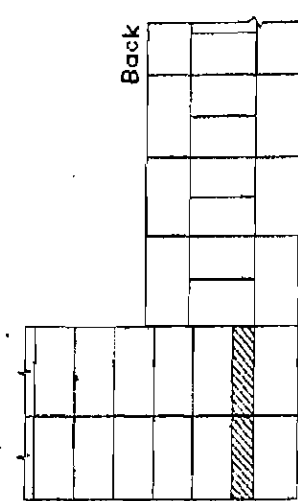

Plan of Stretcher Course

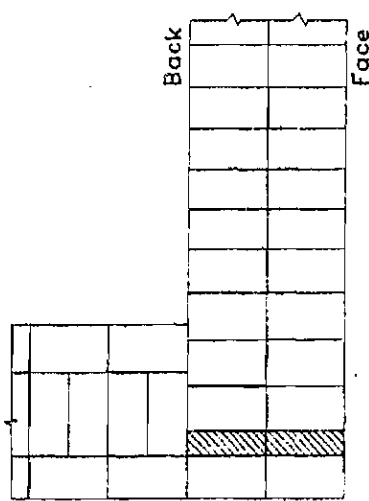

Plan of Header Course

Two Brick wall

Fig. 5.3.9. English bond (L - Junction)

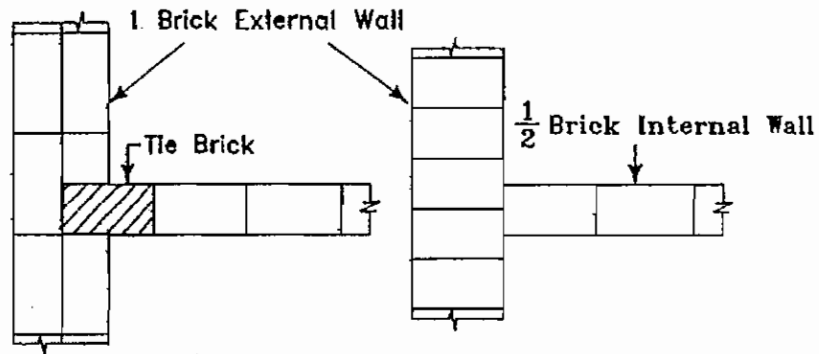

Plans of Alternate Courses  
T-junction

**Brick Masonry**

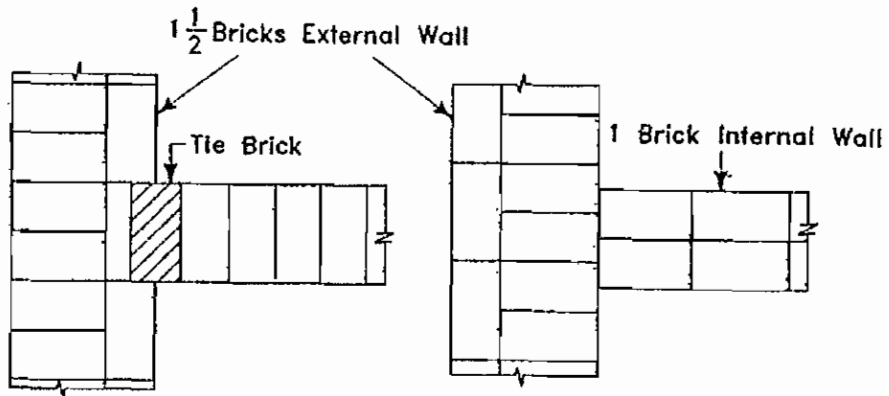

Plans of Alternate Courses  
T-junction

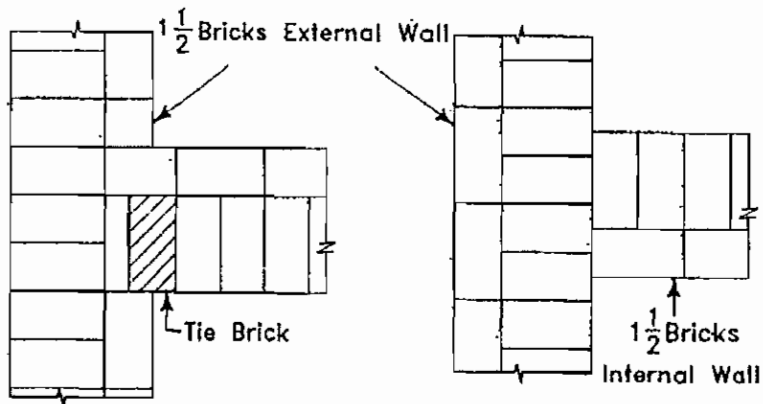

Plans of Alternate Courses  
T-junction

**Fig. 5.3.10 English bond (T - Junction)**

4. Flemish bond

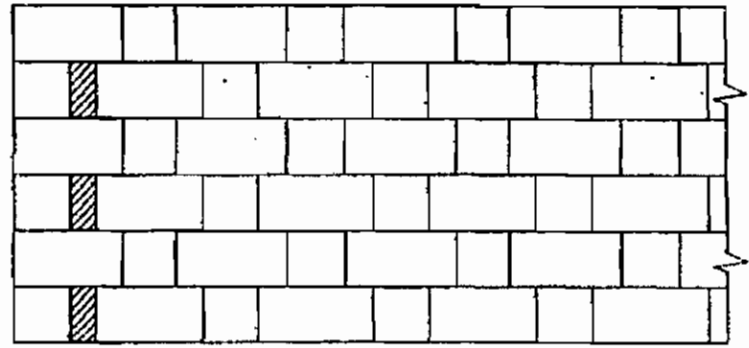

Front Elevation

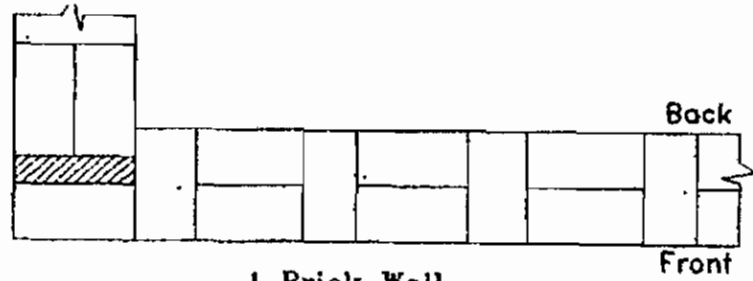

1 Brick Wall

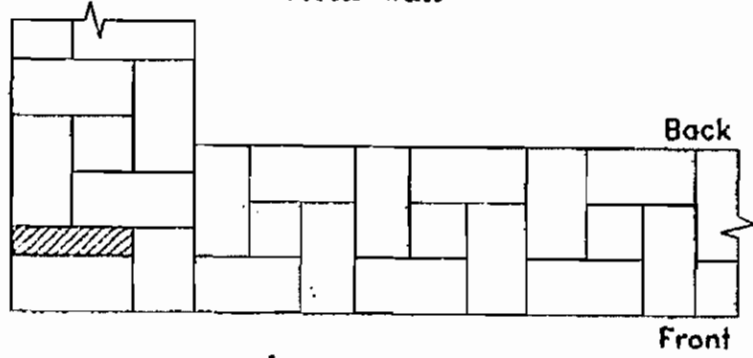

1  $\frac{1}{2}$  Bricks Wall

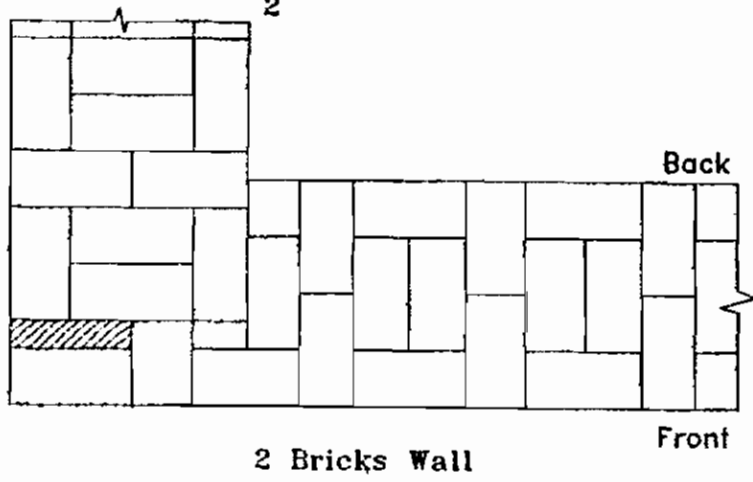

2 Bricks Wall

Courses 2, 4, 6. etc., Double Flemish Bond

Fig. 5.3.11. Flemish bond (L - Junction)

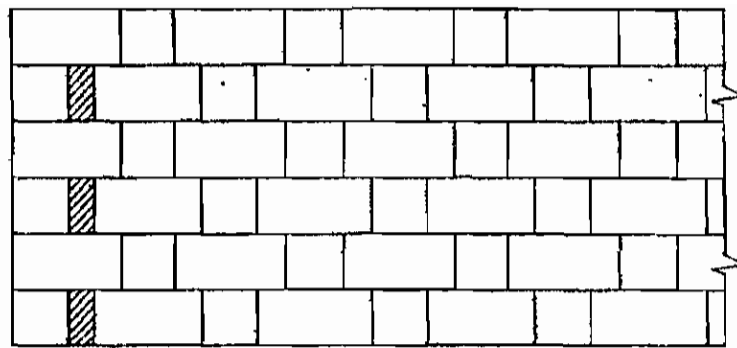

Front Elevation

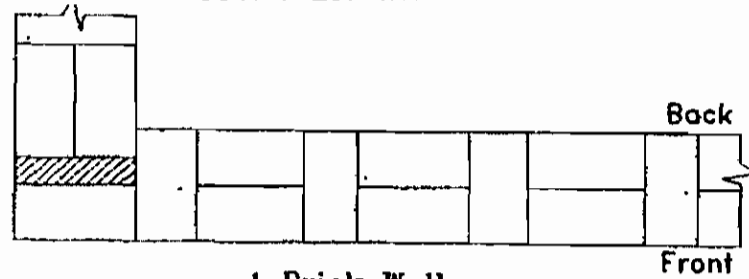

1 Brick Wall

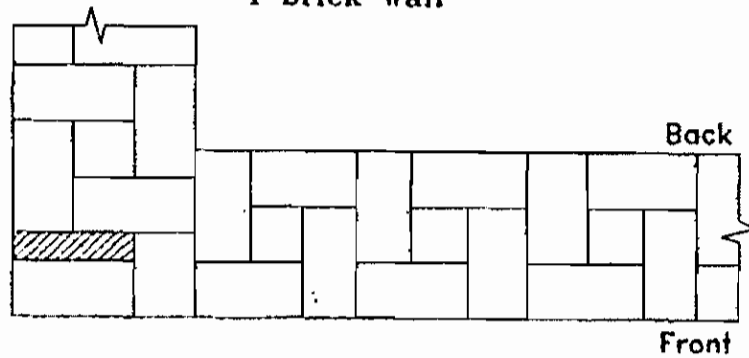

1 1/2 Bricks Wall

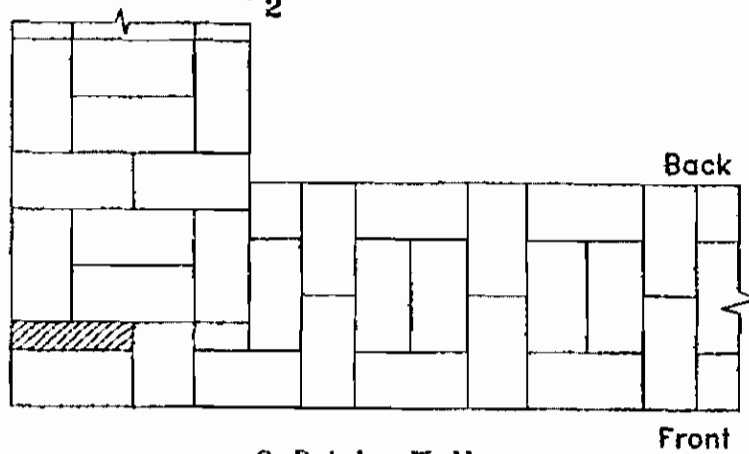

2 Bricks Wall

Courses 2, 4, 6. etc., Double Flemish Bond

Fig. 5.3.12. English bond (L - Junction)

### The important features of Flemish bond

1. Each course consists of alternate headers and stretchers.
2. Queen closers are inserted in alternate courses next to the quoin header.
3. When  $1\frac{1}{2}$ ,  $2\frac{1}{2}$  brick walls are constructed bat bricks are also used with full brick. But when 1, 2, 3 brick walls are constructed only full bricks should be used.
4. Flemish bond is weaker than English bond.
5. Continuous vertical joints may occur in Flemish bond.
6. Flemish bond renders the appearance of the face work more attractive and pleasing.

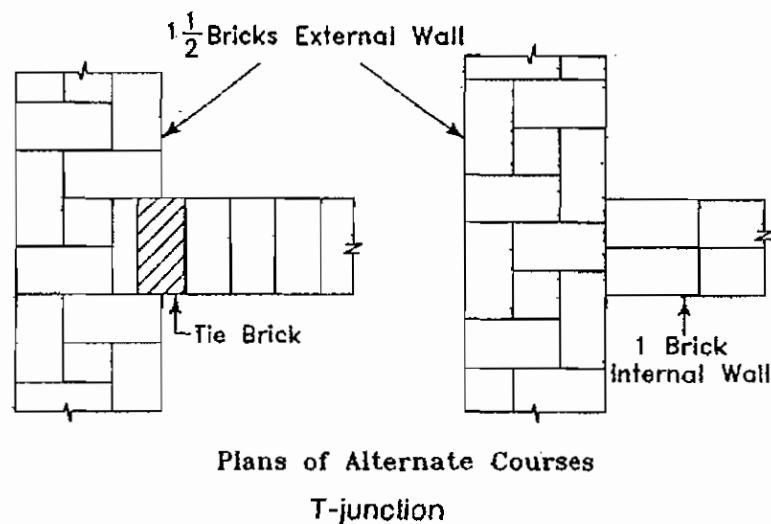

Fig. 5.3.13. Flemish bond (T - Junction)

### 5. Garden wall bond

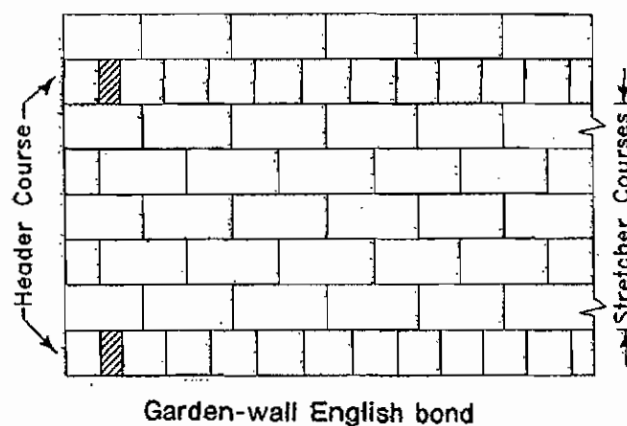
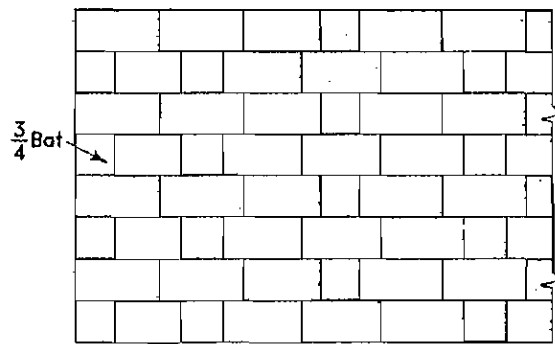

Fig. 5.3.14. Garden wall bond - English bond Junction

These types of bonds are used in compound wall, garden wall. These types of walls are constructed upto 2m height to one brick wall. These type of wall are constructed in English bond or flemish bond. In English bond for three to five stretcher layer one header layer is provided. In flemish bond each layer three or five stretcher course one header course is laid.



Garden-wall Flemish bond

**Fig. 5.3.15. Garden wall bond - English bond Junction**

**6. Raking bond**

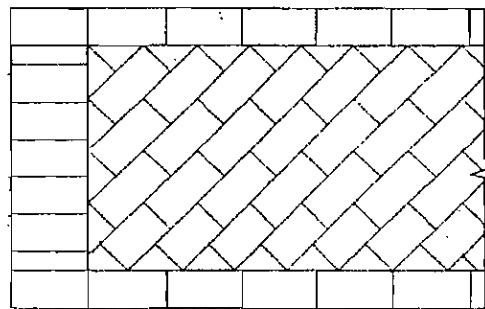

Diagonal bond

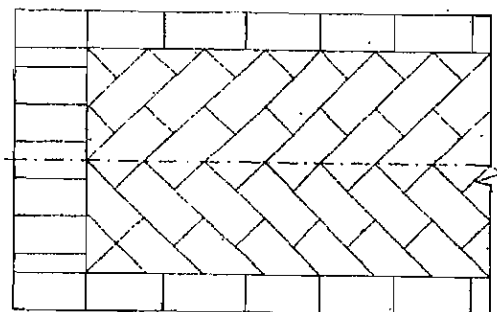

Herring-bone bond

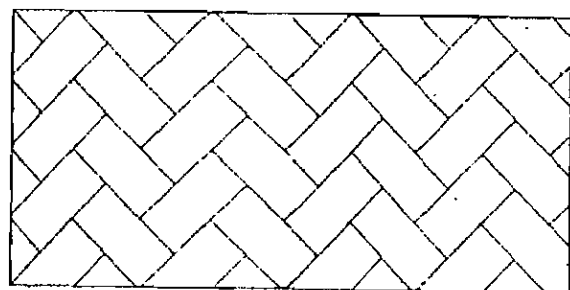

Zig Zag Bond

**Fig. 5.3.16. Raking bond**

This is a bond in brick work in which the bonding bricks are laid at any angle other than zero or ninety degrees. The bricks should be stretchers. The forms of raking bond are.

(a) Diagonal bond (b) Herring bone bond and (c) Zig - Zag bond. These bonds are mostly used for brick floors. Laying the bricks at  $45^\circ$  from the center line of the bricks is called Herring bone bond. This is used for ornamental finishing works.

### 7. Dutch bond

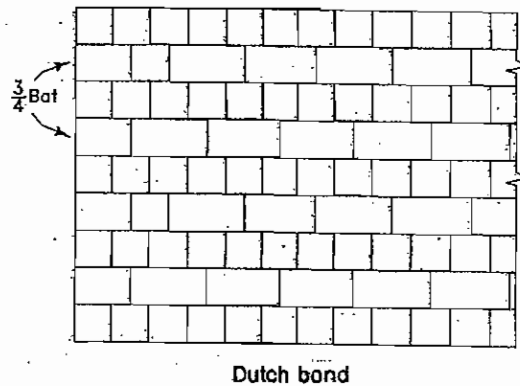

**Fig. 5.3.17. Dutch bond**

This bond is a modification of English cross bond. It consists of alternate courses of headers and stretchers. Each stretching course starts at the quoin with a three quarter bat.

### 8. Brick on edge bond

This is a form of bonding brickwork in which bricks are laid on edge. It is economical but weak in strength and hence it is only recommended for garden walls or partition walls.

#### 5.3.4. Tools used in brick masonry

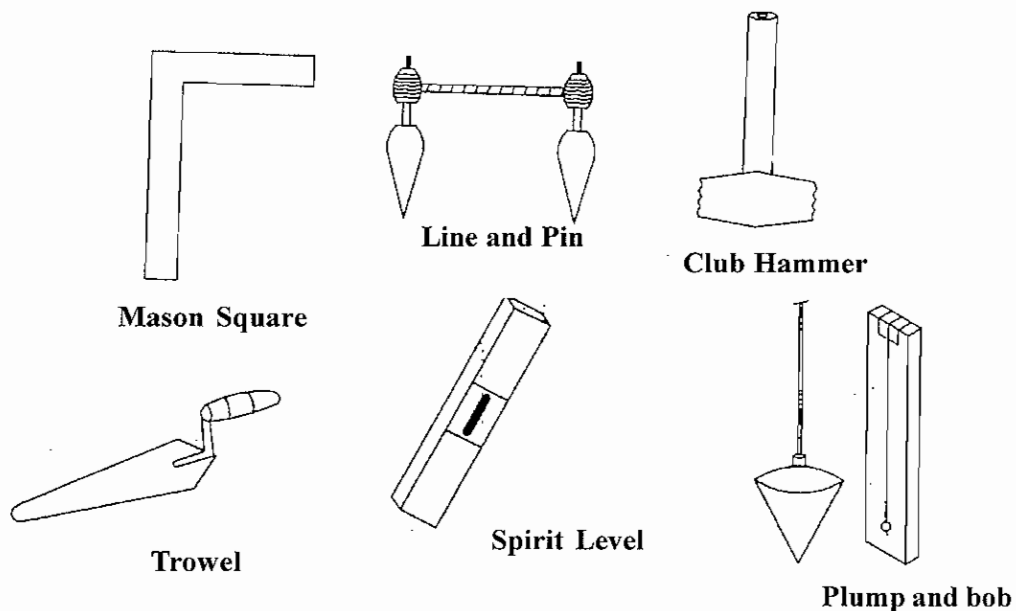

**Fig. 5.3.18. Tools used in brick masonry**

1. **Trowel** : It is used to take and lay the mortar on the brick layer.
2. **Plumb rule and bob** : Used for construct walls vertically.
3. **Sprit level** : It is used to check the horizontal level of walls.
4. **Line and pin** : Used to construct the walls straightly and uniformly
5. **Straight edge** : Used to check the vertical and straight positions of walls.
6. **Square** : Used for set right angles
7. **Club Hammer** : Used to broken bricks.

### **5.3.5. Points to be observed in the construction of Brick masonry**

1. The bricks used in a good work should be sound, hard and well burnt with uniform size, shape and colour.
2. The bricks should be thoroughly soaked in clear water before use. It reduces their tendency of suction of water from wet mortar.
3. Only specified mortar of a good quality should be assed
4. No brick – bats should be used in the work except closers.
5. The progress of work in raising masonry should be in uniform layers at one level.
6. Brickwork should be ensured that a proper bond is maintained through out the work.
7. The bricks should be laid on a full bed of mortar. The frog in the brick should be at the top and filled with mortar to ensure proper adhesion.
8. Scaffolding should be made for construction in higher places.
9. All the course should be laid truly horizontal and all the vertical joints should be truly vertical. The verticality should be checked with plumb bob.
10. All the finished masonry work should be kept wet for at least seven days. Curing for two weeks for cement mortar

### **5.3.6. Thickness of brick wall**

The thickness of brick wall are provided by the following terms

1. The total load action on the wall
2. The total height of the wall
3. The quality of materials used for the construction of wall
4. The length of wall
5. The height between the one floor to other



Let the total load act on the wall be 'P' area of the wall 'A' length of the wall 'L' thickness of wall 'T' admissible bearer capacity 'O'

This is the formula to find the thickness of the wall  $A = P/O$

$$T \times L = P/O$$

$T = P/L \times O$  the thickness of wall.

### 5.3.7. Difference between stone masonry and brick masonry

S.No.	Stone Masonry	Brick Masonry
1	The stones obtained naturally are dressed to a particular shape and used for masonry work.	In this the bricks burnt in kiln and used for masonry work.
2	Stone masonry are very strong .	Strength of brick masonry is lesser than stone masonry.
3	Water tight stone masonry may be constructed.	Like stone masonry water tight masonry work is not possible in Brick masonry.
4	Stone masonry does not have the property of water absorption so this masonry is suitable for bath room and toilets than brick masonry.	Brick walls are having the property of water absorption. To protect the walls from the dampness cement plastering is necessary. When sewage water is sprinkled on the walls the bricks are eroded and attains the powder form.
5	Even though stone masonry is hard but construction is tough.	Construction of brick masonry work is very easy.
6	Bonding property is not much high as in brick masonry and consumption of cement mortar is also high.	Good bonding property is available in brick work. Less quantity of cement or lime mortar is used.
7	Lifting and handling of stones are tough. So speed of masonry work is slow.	As the size of brick is small handling and lifting is easy. So masonry work is faster.
8	In hilly areas stones are highly available so construction cost is low	Other than hilly area cost of brick work is economical.
9	We can not directly use the stone which are taken from stone quarry. It should be required to some extent so cost becomes high.	We can use the bricks directly from the kiln so cost becomes low.
10	Minimum width of stone masonry should be 30cm construction of stone masonry below this width is tough.	We can construct brick walls from 10cm to 20cm.
11	Heat absorption property is high for stone masonry.	Heat absorption property is not much high.

## QUESTIONS

### Part-A

#### I. Choose the best answer and write

- 1) The name of bottom portion when laying brick in stretcher coarse (or) header coarse in brick masonry wall.  
a) Bond                                      b) Bed                                      c) closer                                      d) stretcher
- 2) The portion of brick cut in stretcher and header coarse is named as  
a) king closer                                      b) queen closer                                      c) Bewelled closer                                      d) Mitred closer
- 3) Allowable bearing capacity of Brickwork constructed in Mud Mortar  
a) 200 KN/m<sup>2</sup>                                      b) 650 KN/m<sup>2</sup>                                      c) 550 KN/m<sup>2</sup>                                      d) 400 KN/m<sup>2</sup>
- 4) Height of Garden wall Bond  
a) 1 m                                      b) 2 m                                      c) 2 m                                      d) 4 m
- 5) Instrument used to break the brick  
a) Trowel                                      b) Nail                                      c) Spirit level                                      d) Hammer
- 6) Instrument used to check the level of wall in horizontal position  
a) Trowel                                      b) Nail                                      c) Spirit level                                      d) Hammer
- 7) Instrument used to check the construction of wall in vertical position  
a) Trowel                                      b) Plum bob                                      c) Hammer                                      d) Nail

### PART-B

#### II. Answer in one (or) two sentences

- 1) What is meant by Queen closer?
- 2) Write two types of Bonds in Brick Masonary.
- 3) Where header bonds are used.
- 4) Howbricks are provided in Flemish Bond.
- 5) Which bond is good in appearance.
- 6) Which is low strength bond than Flemish bond.
- 7) What is the closer provided next to Corner stone.
- 8) What is the use of Plumb bob.

### **PART-C**

- 1) Write short notes on (a) Queen closer, (b) King closer.
- 2) What is meant by stretcher, Header of a brick.
- 3) Define Brick Masonry.
- 4) Define  $\frac{1}{2}$  brick  $\frac{3}{4}$  bricks.
- 5) Define Frog.
- 6) Write two types of bond.
- 7) Write five materials used in Brickwork.
- 8) What is the use of Plumb bob.

### **PART-D**

- 1) What are the points to be noted in brick work.
- 2) Draw the Top elevation, Front elevation of one brick English bond with 'L' Joint.
- 3) Draw the top elevation, Front elevation of one brick Flemish Bond with 'L' Joint.
- 4) Write materials used in Brick masonry and their uses.
- 5) Write difference between Racking Bond and Garden wall bond and draw the sketch.

### **PART-E**

#### **V. Answer in Detail:**

- 1) Write the terms used in Brickworks and define with neat sketch.
- 2) Write types of Brick masonry and define any five with neat sketch.
- 3) Define English bond with sketch.
- 4) Define Flemish bond with sketch.

## UNIT – VI

### 6.1 ARCHES AND LINTELS

#### 6.1.1. Introduction

An arch is a structure which is constructed to span across openings such as doors, windows etc. Generally it consists of a small wedge shaped bricks (or) stone blocks which are joined together with mortar and supported at the abutments and piers.

#### 6.1.2. Terms Used in arches

**1. Intrados**

The inner curve of an arch is known as intrados.

**2. Soffit**

This is the inner surface of the arch. Sometimes the terms, intrados and soffit are treated as synonymous.

**3. Extrados**

The external curve of an arch is known as extrados.

**4. Abutment**

This is the end support of an arch

**5. Pier**

These are the intermediate supports of an arcade

**6. Skew Back**

This is an inclined surface on the abutment. The arch commences from this only.

**7. Springer**

This is the first voussoir at springing level on either side of an arch.

**8. Springing Point**

These are the points from where the curve of an arch starts.

**9. Springing Line**

This is the imaginary horizontal line joining the two springing points.

**10. Crown**

This is the highest point of the extrados.

**11. Key**

This is a wedge shaped unit at the crown of an arch.

**12. Span**

This is the clear horizontal distance between the supports.

**13. Rise**

This is the clear vertical distance between the highest point on the intrados and springing line.

**14. Centre**

This is the geometrical centre of the curve of an arch

**15. Depth**

This is the perpendicular distance between the intrados and Extrados.

**Fig. 6.1.1. Terms used in the Arches**

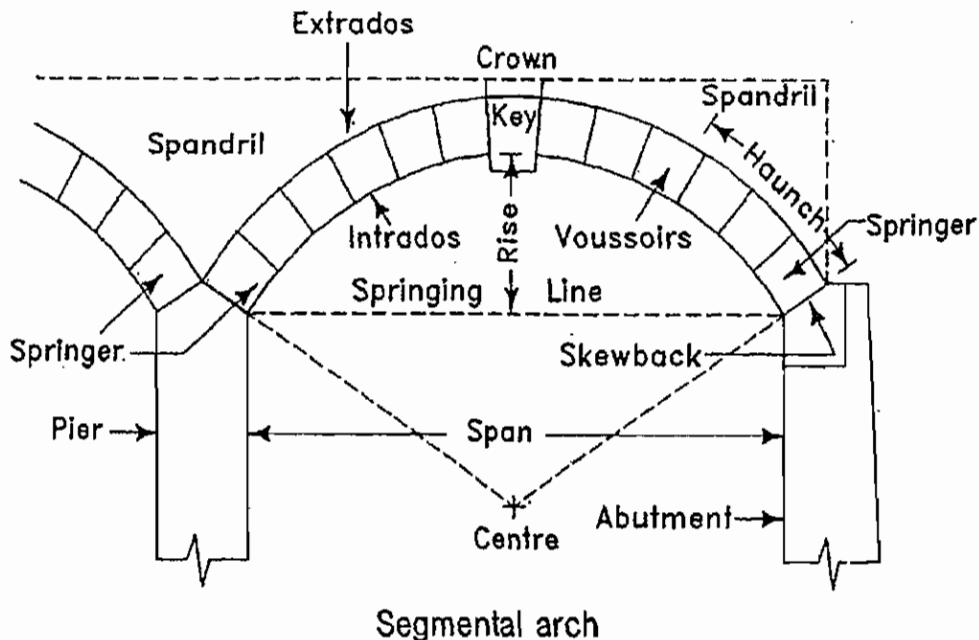

**16. Haunch :** It is the lower half portion of the arch from the springing to the mid way to the crown from either side.

**17. Arcade :** This is row of arches supporting a wall above and being supported by the piers.

**6.1.3. Types of Arches**

**1. According to Shape**

- Flat arch
- Segmental arch
- Semicircular arch



## Circular arch

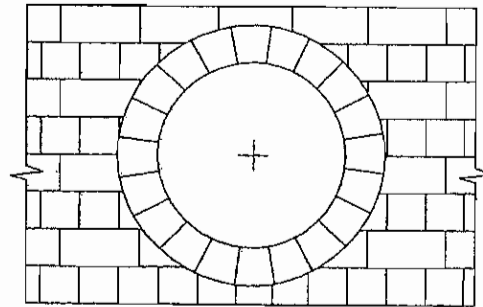

Bull's eye arch

**Fig. 6.1.3. Circular arch**

## Segmental arch

This type of arch is segmental in shape and its centre lines below the springing line. The bed joints of the voussoirs radiate from the centre of the arch. The depth of segmental arches may be 20 to 30 cm according to the class of work, width of opening etc. The segmental arch is used for various sizes.

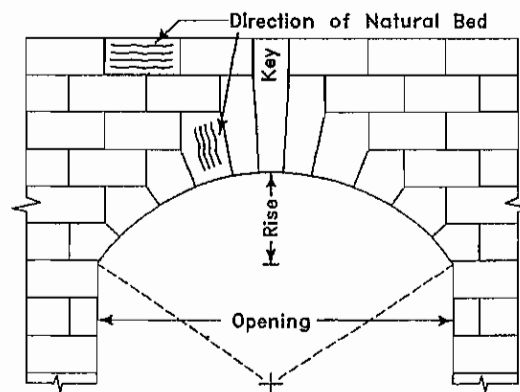

Segmental arch

**Fig. 6.1.4. Segmental arch**

## Inverted Arch

The arches are used in foundations Inverted arches are provided to reduce the depth of foundations where the bearing capacity of soil is low These are useful in the construction of foundation where Bridges, small Dams water tank are constructed.

### 6.1.4. Centering for arches

These are temporary structures which are required to support brick, stone (or) concrete arches during their construction. It is called centering the upper surface of the centering corresponds to the shape of intrados of the arch. The centering for arches consists of two parallel boards. The boards upper surface are curved in shape on both sides Boards are supported by wooden strips. These wooden strips are used to support the bricks (or) stones these wooden strips are also called as laggings. The above seen boards are 30 mm depth and 30 cm in breath breadth

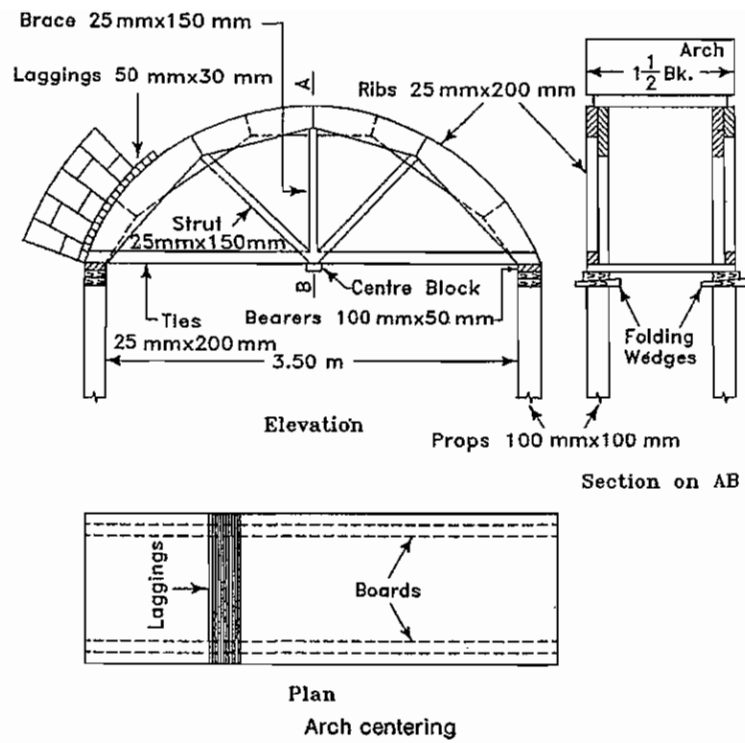

**Fig. 6.1.5. Centering for arches**

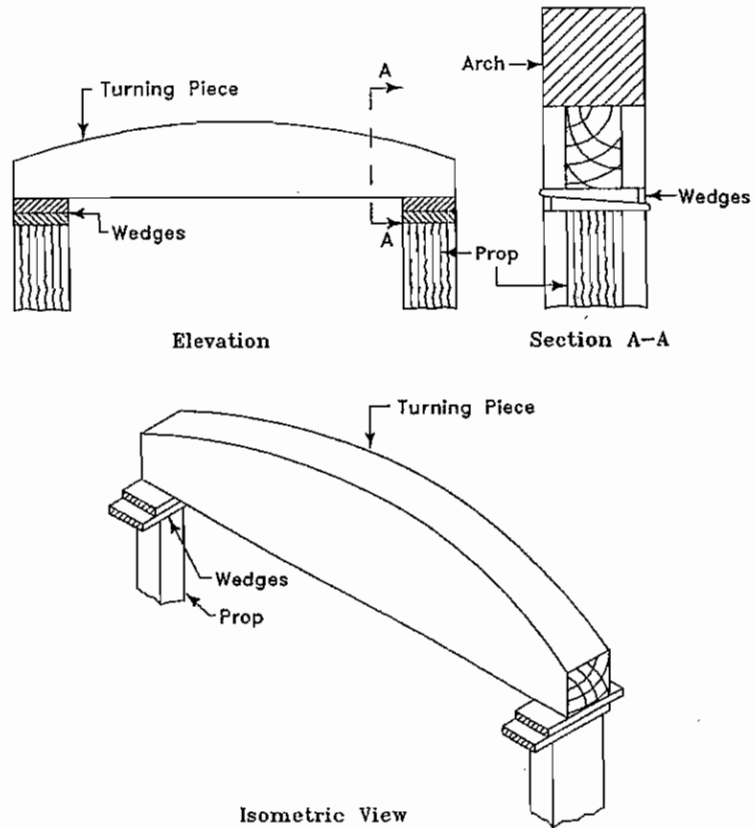

**Fig. 6.1.6. Z**



### Points to be noted in providing centering

- 1) According to the width of Arches the distance of wooden board and length of laggings are decided.
- 2) The laggings are kept 10 mm back from the arch work. Thus it will not be hurdle to check with plumbob during the construction of arch.
- 3) After attaining required strength the centering of arch should be removed. The removal of centering is done by slightly loosening the folding wedges.

### 6.1.5. Lintels

#### Definition

A horizontal member provided over the opening of door or window so as to take up the above opening is known as lintel.

Types of Lintels based on the materials of construction

1. Wooden lintel
2. Stone lintel
3. Brick lintel
4. Steel lintel
5. R.C.C. lintel

#### 1. Wooden lintels

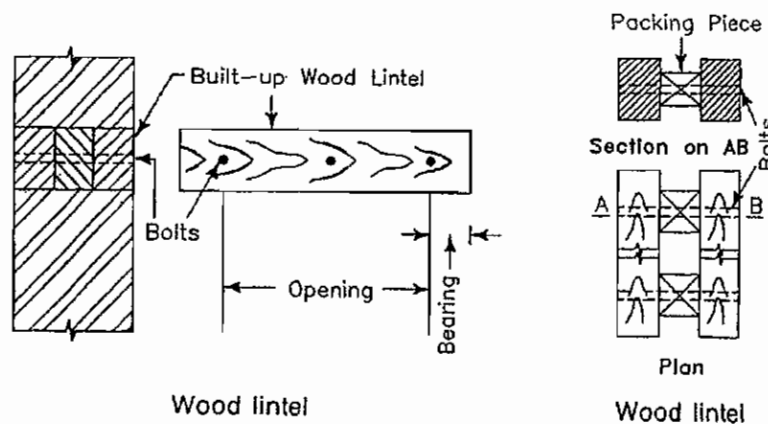
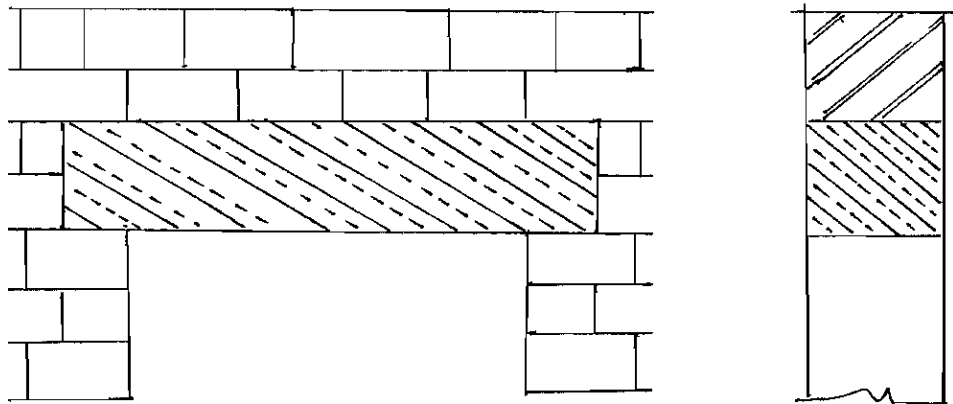

Fig. 6.1.7. Wooden lintels

Wooden lintels are commonly used in hilly areas where timber is cheaply available in abundance. In plants, the wooden lintels are rarely used on account of their high cost, susceptibility to catch fire and ability to decay by rot on certiries. Wooden lintels should be made of sound and hard timber. The amount of bearing of lintel ends should be adequate (usually 15 to 20 cm) The depth of lintel should be  $1/12^{\text{th}}$  of span or 8 cm whichever is greater. The width of the lintels is taken equal to the thickness of the opening.

## 2. Stone lintels

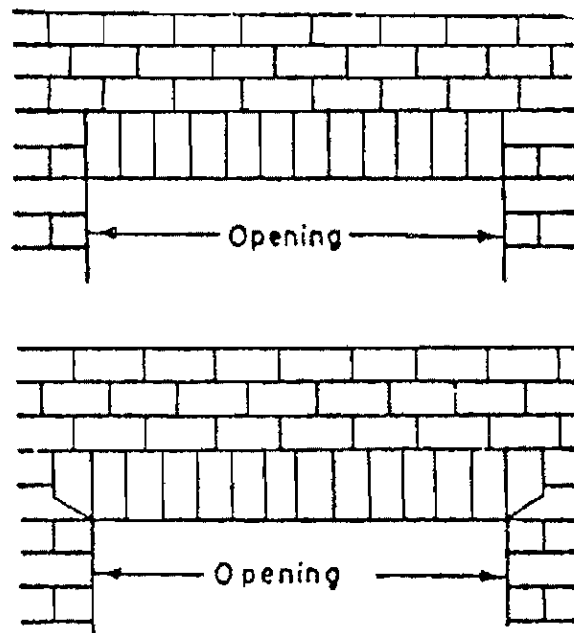

**Fig. 6.1.8. Stone lintels**

The use of stone lintels is recommended only in places where stone is available in p'entry and the structure is made of stone masonry. Stone lintels are constructed of slabs of stones of sufficient length without flaws. The thickness of the stone lintel should be 4 cm for every 30 cm of span.

Stone, being poor in tensile strength cannot withstand the transverse stress. Hence, stone lintels should never be used for opening more than 1 m in span. It is difficult to obtain the slabs of stones of sufficient length and depth, free from defects or flaws.

## 3. Brick lintels



**Fig. 6.1.9**

These lintels consist of bricks which are generally placed on end or edge. The bricks should be well-burnt, copper-coloured, free from cracks, with shape and square edges. A temporary wood support, known as a turning piece, is used to construct a brick lintel. In order to maintain the appearance of brickwork, a brick lintel should have a depth equal to some multiple of brick courses. A steel angle or steel flat bar of length equal to brick lintel may be provided at the bottom of lintel.

#### 4. Steel Lintels

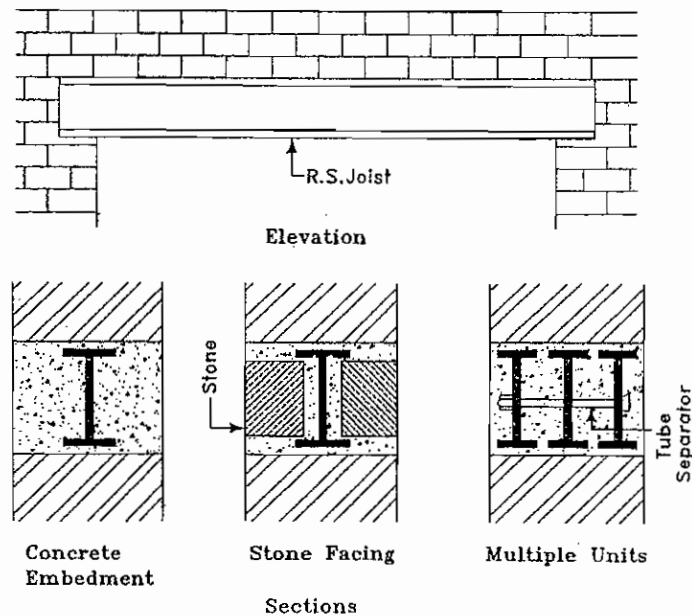

Fig. 6.1.10. Steel lintels

These lintels usually consists of built up sections of three rolled steel joists or channel sections which are held together at proper distances by tube separators. These built up sections are embedded in concrete to protect them from the effect of corrosion. The whole system is cured like a R.C.C. lintel.

#### 5. Reinforced cement concrete lintels

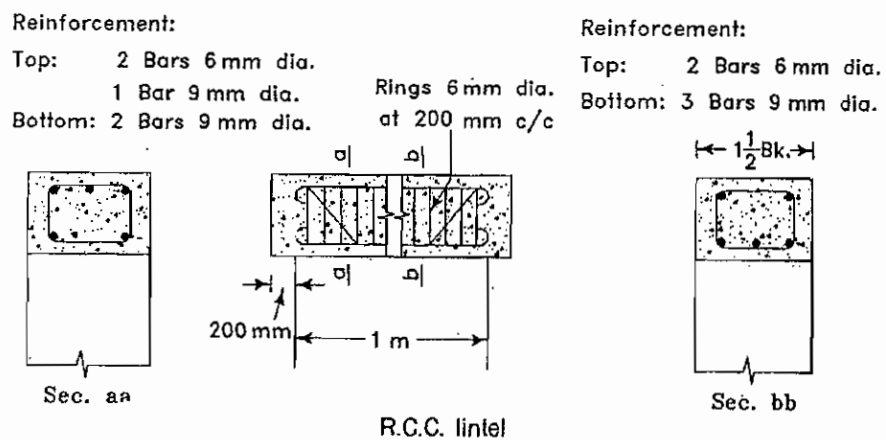
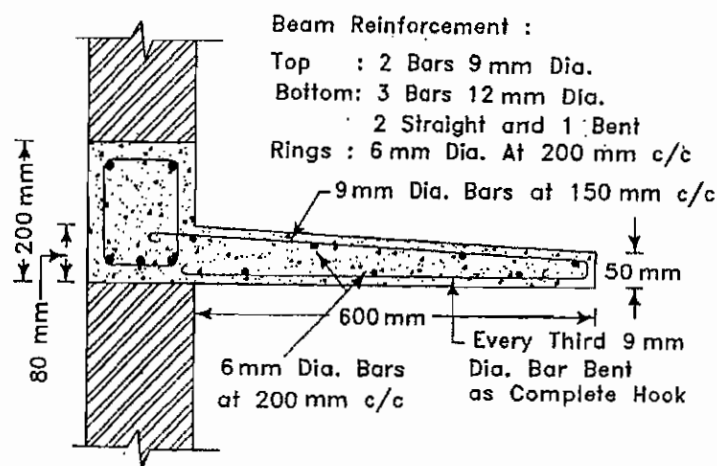

Fig. 6.1.11. R.C.C. Lintel

These lintels consists of the reinforced cement concrete and they have replaced practically all other materials for the lintels. The R.C.C. lintels are fire-proof, durable, strong, economical and easy to construct. No relieving arches are necessary when the R.C.C. lintels are adopted.

The usual concrete mix for R.C.C. lintel is 1:2:4 i.e. 1 part of cement, 2 parts of sand and 4 parts of aggregates by volume. The plain concrete lintels can be used upto a span of about 800 mm. But some form of reinforcement is necessary in the R.C.C. lintels as plain concrete is weak in tension. The amount of reinforcement depends on the span of lintel, width of opening and the total load to be supported by the lintel.

Some times to provide sunshade monolithically with the lintel. Lintel cum sunshade are joint together and sunshade is projected.



R.C.C. lintel and weather shed

**Fig. 6.1.12. R.C.C. Lintel cum Sunshade**

### 6.1.6. Difference between arches and lintels

SLNo	Arches	Lintels
1	Curved in shape.	Horizontal in shape.
2.	Giving unnecessary rises over door and window openings.	There is no unnecessary rises in lintels.
3.	Good for uniformly distributed loads and weak in point loads.	Strong in U.d.l. as well as point loads.
4.	Joints should be in radial shape.	Joints should be vertical
5.	Supported at the abutments and piers.	There is no supports like piers and abutments.
6.	Arches giving good appearance to the buildings.	Giving ordinary appearance to the buildings.

## QUESTIONS

### PART-A

#### Choose the best answer and write

- 1) Depth of circular portion in Arches  
a) 20 to 30 mm      b) 40 to 50 cm      c) 70 to 80 cm      d) 100 to 120 cm
- 2) The arches constructed in low bearing capacity of soil.  
a) Inverted arch      b) parabolic arch      c) semi circular arch      d) Horseshoe arch
- 3) The material used to avoid termites in wooden lintel.  
a) Cement      b) sand      c) paint      d) Brick
- 4) Nature of RCC lintel.  
a) Not strong      b) strong      c) beautiful      d) all the above
- 5) The concrete ratio used in Reinforced Concrete Lintel  
a) 2:3      b) 1:2:3      c) 3:2      d) 1:2:4
- 6) In continuous arch the bearing portion of curve on both dead ends.  
a) pillar      b) abutment      c) crown      d) span
- 7) The word used in Arches  
a) curve      b) landing      c) pier      d) lintel

### PART-B

#### II. Answer in one (or) two sentences

- 1) What are intrados?
- 2) What is a soffit?
- 3) What are extrados?

- 4) What will be the angle between skew back of a Hatarer and horizontal is kept?
- 5) What is a pier?
- 6) Write any 3 words used in Arches?
- 7) What should be the depth of a wooden lintel?
- 8) What should be the concrete ratio followed for reinforced concrete lintel.
- 9) Where the lintels are provided in a house?
- 10) Which lintel are used as beam.

### **PART-C**

#### **III. Answer in one (or) two sentences:**

- 1) Define lintel?
- 2) Classify the Arches according to material.
- 3) What is an arch.
- 4) What are the types of lintels?
- 5) Define keystone and crown.
- 6) Write short notes on stone lintel.
- 7) Write short notes on flat arch.
- 8) Define intrados and Extrados.
- 9) Define Span and Depth.

### **PART-D**

- 1) Tabulate the difference between Lintels and arches.
- 2) Draw the figure of Lintel and sunshade and illustrate the points.
- 3) Write the types of Arches and define any two with sketches.
- 4) Draw any one type of arch and illustrate the parts.

### **PART-E**

#### **V. Answer in Detail:**

- 1) Draw an arch and define the terms used in it.
- 2) Write the types of lintels and define with sketch.

## **6.2. CARPENTRY AND JOINERY**

### **6.2.1. INTRODUCTION**

Carpentry is the term applied to that form of wood work in which the wooden members are subjected to loads or thrusts. The work man who handles the work of carpentry is called a carpenter.

Joinery may be defined as the trade in wood work in which skilled labour is required to render the wooden members capable of framing together. In our country carpentry and joinery are treated as a single trade. The man who handles the work of carpentry and joinery is called a carpenter.

### **6.2.2. TERMS USED IN CARPENTRY**

#### **1) Sawing**

Sawing the wood with a saw.

#### **2) Shooting**

Shooting the edges of wood as straight and square.

#### **3) Chamfering**

It consists in taking off the edges of a wooden member to  $45^{\circ}$ .

#### **4) Bevel**

Sloping the edges above  $45^{\circ}$ .

#### **5) Planing**

The process of taking the shavings off wooden member is called planing

#### **6) Mitering and scribing**

It is the process of framing one molding into the face of another at an interior angle.

#### **7) Molding**

It is the process of molding the wood by hand or by machine.

#### **8) Rebating**

It is the process of cutting a rectangular groove along with the edge of a member.

#### **9) Housing**

It is the process of cutting groove in a timber piece across its grain, So as to permit the insertion of another member in it .

#### **10) Grooving**

Cutting grooves parallel to its grain.

### **11) Nosing**

Projection from a vertical face is called as nosing.

### **12) Studding**

It is the term applied to the fixing of small timber battens, to timber walls to which lather and boards are to be nailed.

### **13. Batten**

It is the name given to a narrow strip of wood normally nailed over joints of boards.

### **14) Veneering**

It is the process of covering the exposed surface of a wooden member with a thin sheet to improve the appearance of the member.

### **6.2.3. Principles governing the construction of Joints**

The appearance and durability of the wooden members are according to the joints made. More joints should reduce the strength of members. So in carpentry joints the following points should be considered.

- 1) The wooden members may be framed together to serve the purpose.
- 2) Joint the wooden members across its grain.
- 3) Compressive stress should be in all joints
- 4) The pressure should be equal and uniformly distributed on all joints.
- 5) All the joints must have the equal strength.
- 6) The joints should not be affected by shear force and crushing.

### **6.2.4 Types of joints**

Some important types of joints used in carpentry works are given below.

#### **1) Butt joint**

Butt or plain joint is formed by laying the boarding side by side as shown in figure (11.1)

#### **2) Rebated joint**

Rebated joint is formed by cutting rectangular depression in each board and the end lapped over one another.

#### **3) Rebated and fillet joint**

Rebated and fillet joint is similar to tongued and ploughed joint with only difference that the hard wood piece is situated at the lower face of the boarding.



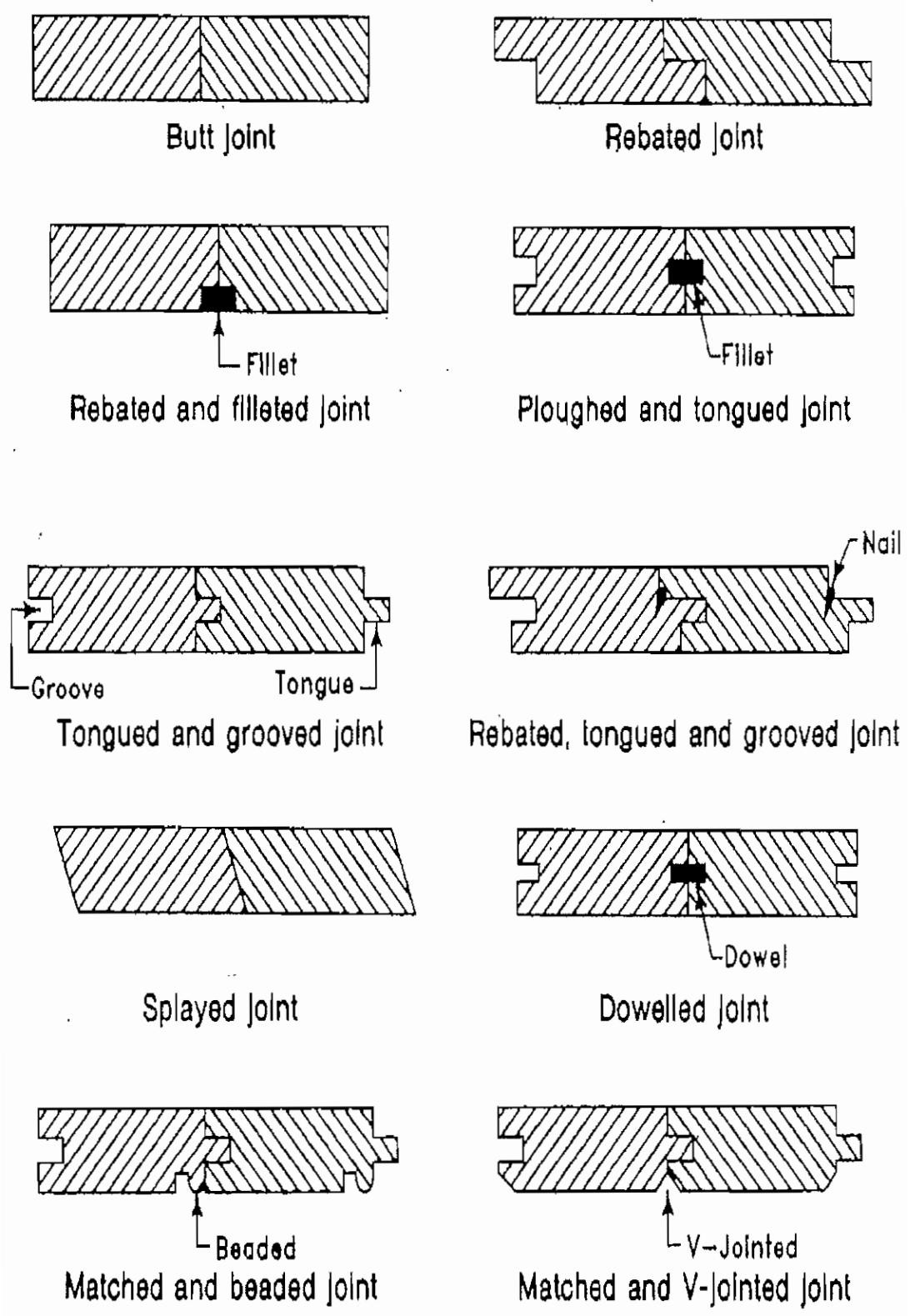

**Fig 6.2.1. Types of Joints**

#### **4) Tongued and ploughed joint**

In tongued and ploughed joint each board is cut so as to have tongue on one edge and groove on the other and a hard wood piece called plough is fitted tight between successive boards.

#### **5) Tongued and grooved joint**

In tongued and grooved joint each board is cut so as to have tongue on one edge and groove on the other end joint together.

#### **6) Rebated tongued and grooved joint**

Rebated tongued and grooved joint is formed by so shaping the tongued and grooved ends of the members that rebate is also formed by cutting an additional with one side of the tongued member.

#### **7) Splayed joint**

Splayed joint is similar to butt joint except that the edges are splayed.

#### **8) Dowelled joint**

Dowelled joint is similar to tongued and ploughed joint. This is a very strong joint. The joints are provided by filling with metal, brass, copper in the grooved place.

#### **9) Matched and beaded joint**

Matched and beaded joint is a modified form of tongue and grooved joint. In this type of joint the tongued edge of each board has special moulding for good appearance.

## QUESTIONS

### Part-A

#### I. Choose the best answer and write

- 1) The word used in carpentry work.  
a) shooting                      b) joint                      c) Lintel                      d) Joinery
- 2) Carpentry Joint  
a) Planning                      b) Butt joint                      c) carpentry                      d) Joinery
- 3) The name of cutting the corner edge of a wooden piece by more than 45°  
a) 60°                      b) 90°                      c) 45°                      d) 30°
- 4) Planning so called in carpentry work.  
a) sawing                      b) shavings                      c) shooting                      d) Housing
- 5) Type of force should act when joining are provided in carpentry work.  
a) Tensile force    b) Breaking force    c) compressive force    d) Force of wind pressure.
- 6) Type of force should not affect when joining are provided  
a) Tensile force                      b) compressive force  
c) Inclined force                      d) force of wind pressure.
- 7) Other name of Butt Joint  
a) Rectangular joint    b) square joint                      c) Cone joint                      d) Circular joint.
- 8) The joint provided for good appearance  
a) matched                      b) Grooved                      c) Splayed                      d) Butt joint.
- 9) Method of cutting the timber by Hacksaw  
a) Moulding                      b) Grooving                      c) sawing                      d) Bewel

### PART-B

#### II. Answer in one (or) two sentences

- 1) Write the words used in carpentry work.
- 2) What is meant by sawing?
- 3) What is planning?
- 4) What are the other name of Butt Joint.
- 5) What is meant by Bolton Batten?
- 6) Write the uses of Rebate joint?

- 7) What is meant by Grooving?
- 8) How the person called while working for architectural carpentry work?

**PART-C**

**III. Answer in one (or) two sentences:**

- 1) What do you mean by carpenter (or) Joiner?
- 2) Define two words used in carpentry work?
- 3) Write three types of carpentry joint?

**PART-D**

- 1) Define Carpentry?
- 2) Draw any two carpentry joint?

**PART-E**

**V. Answer in Detail**

- 1) What are the points noted while Joining carpentry?
- 2) Define the words used in carpentry work.

## 6.3. DOORS AND WINDOWS

### 6.3.1. INTRODUCTION

A door may be defined as a frame work secured in an opening left in a wall for the purpose of providing access to the uses of the structure. A window may be defined as an opening made in a wall for the purpose of providing daylight, vision and ventilation.

Store room requires only light window may be fixed so that they can not be opened.

### 6.3.2. TERMS USED IN DOORS AND WINDOWS

#### Door frame or Window frame

Door frame or window frame is made up of two vertical members and which are secured by one or two cross pieces at top and bottom.

#### Shutter

Shutters are generally made up of timber frame work with panel insets of glass, timber or plywood. Shutter frame work should have styles, top rail, bottom rail, locking rail and panel.

#### Style

The vertical members in both sides of shutter in style.

#### Top rail

The horizontal member in the top of shutter is termed as top rail.

#### Bottom rail

The horizontal member in the bottom of shutter is called as bottom rail.

#### Lock rail

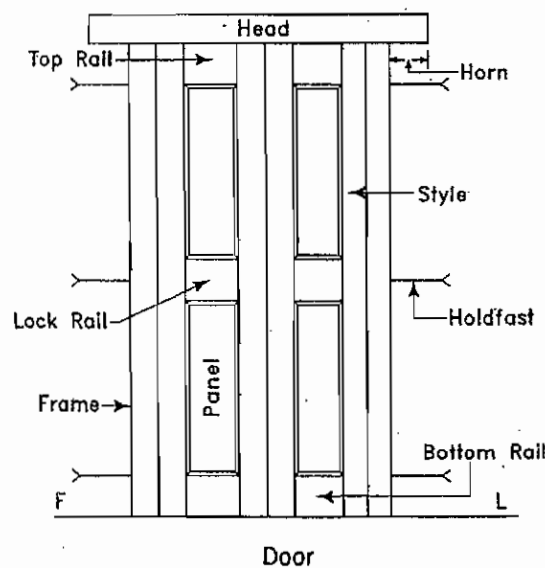

Fig. 6.3.1. Terms used in doors

The horizontal member in the shutter in between top rail and bottom rail to fit locks is called as lock rail.

### **Panel**

The portion inside the shutter frame work in termed as panel.

### **Sash**

The frame made for glass like panels is called as sash.

### **Mullion**

The vertical member which separates the shutter in the middle is mullion.

### **Transom**

The horizontal member which divides the shutter into two parts is called as transom.

### **Louver**

The small strips of wood fixed inclined in the shutter is called as louver.

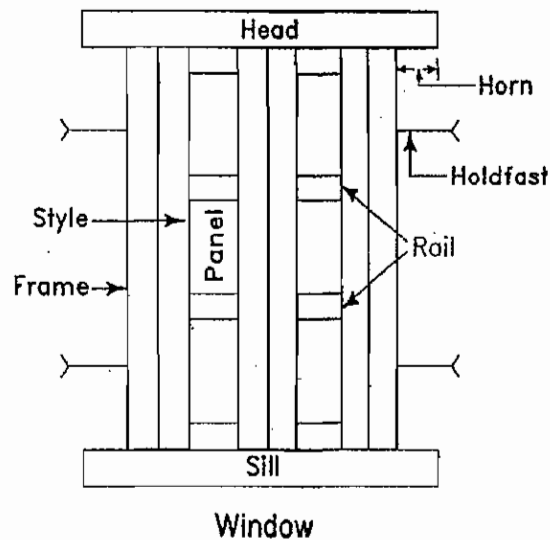

**Fig 6.3.2. Terms used in Windows**

### **Putty**

The mixture of lime and lined oil used for fixing the glass with shutters is termed as putty.

### **6.3.3. Size and Location of Doors and Windows**

The following guidelines should be kept in view while deciding the location of doors and windows in a building.

- i) Doors should as for as possible be located near the corner of a room, about zoom a way 20 cm from the corner.

- ii) The number of doors in a room should be kept minimum to achieve optimum utilization of space. Large number of doors besides causing obstruction, consume more area in circulation.
- iii) The window sill should be placed at 75 to 100 cm above the floor level.
- iv) Windows should be located opposite to each other wherever possible.
- v) The size and number of windows should be sufficient to provide adequate light, ventilation and privacy in the room.
- vi) The shutters of windows in external walls should open out side.

#### **6.3.4. The size of doors**

Doors inside the houses - 0.90m X 2.00 m

External doors - 1.00 m X 2.00 m

Bathroom doors - 0.70 m X 2.00 m

Doors in the public buildings

Like schools and hospitals - 1.20 X 2.25 m

Car shed - 2.25 X 2.75 m

The minimum height of the doors should be 1.8 m

Generally the width of the door = 0.4 to 0.6 X height

Or

Height = width + 1.2.m

#### **6.3.5. TYPES OF DOORS**

1. Ledged doors.
2. Ledged and braced doors.
3. Ledged and framed doors.
4. Ledged, braced and framed doors
5. Framed and paneled doors.
6. Glazed doors
7. Flush doors.
8. Louvered doors.
9. Collapsible doors.
10. Revolving doors.

- 11. Rolling doors.
- 12. Sliding doors.

### 1. Ledged doors

This door consists of a series of vertical battens fixed together with horizontal members known as ledges. There are three ledges named top ledge, bottom ledge and middle ledge. The door is hung on the frame by iron hinges called T-hinges or cross garnet hinges. These types of door are mostly used for rooms where economy rather than the appearances is of main consideration.

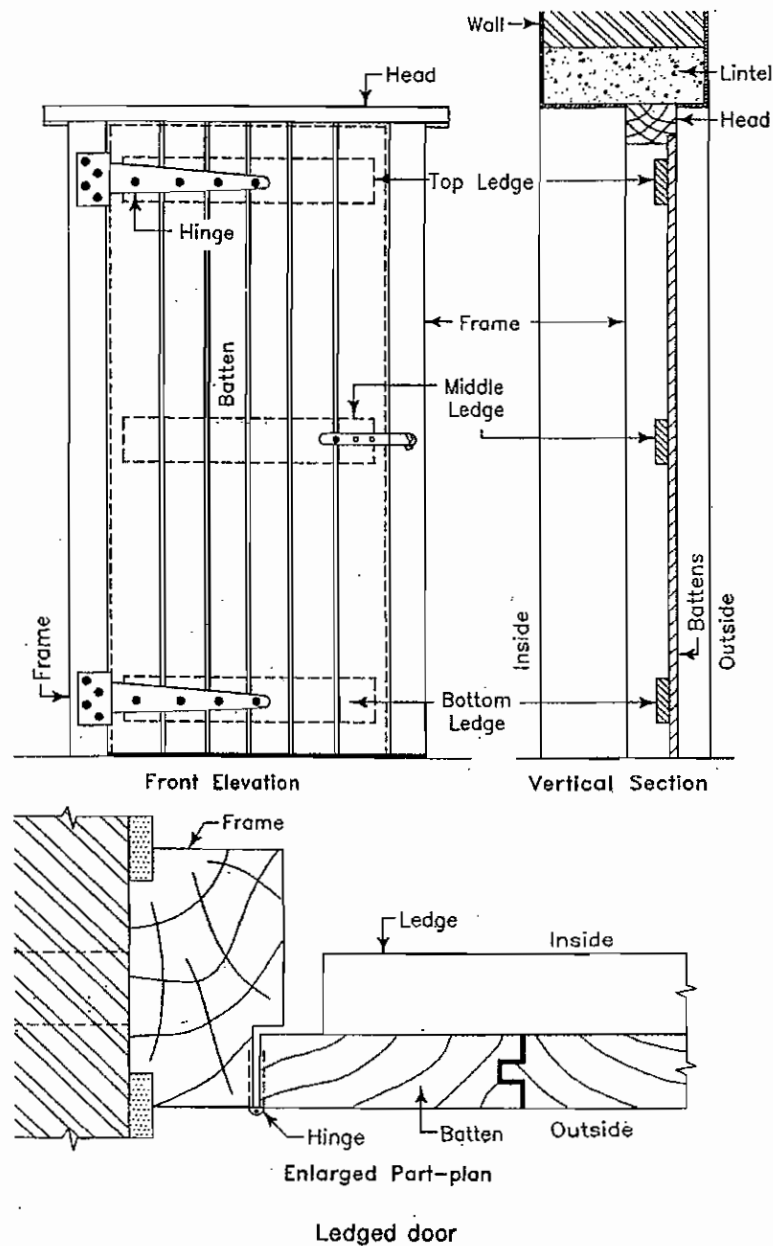
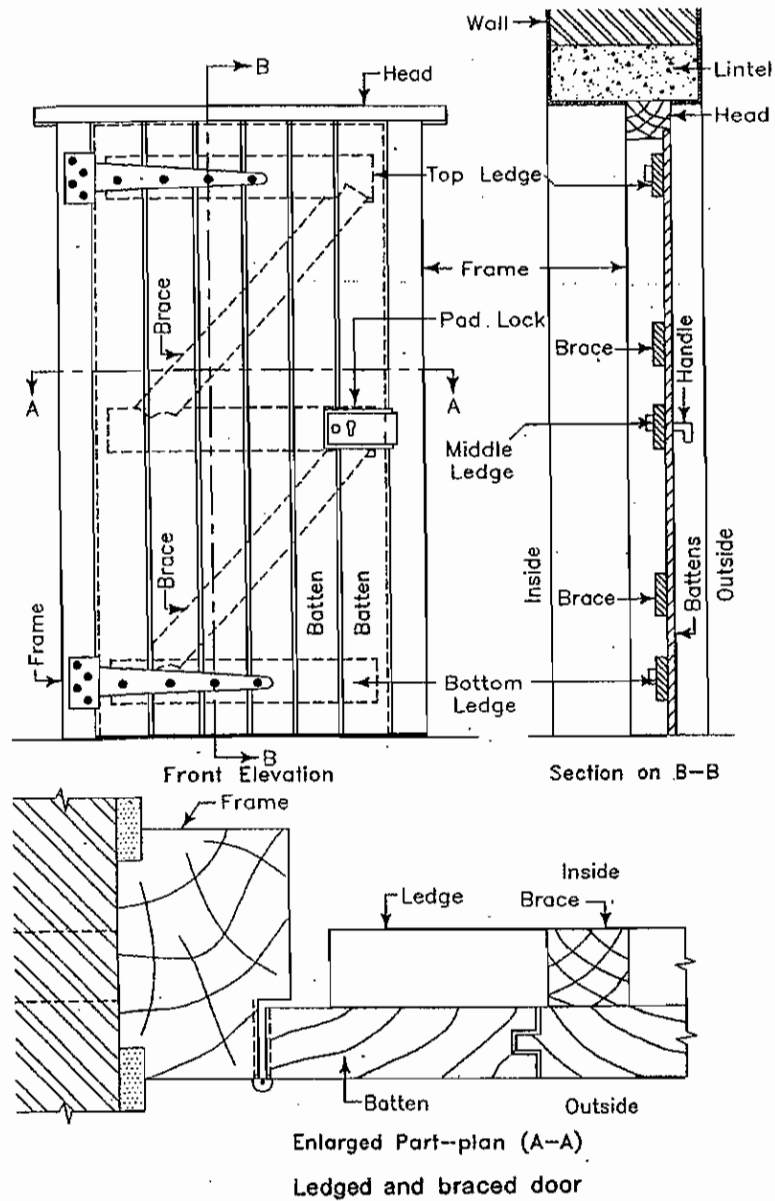

**Fig. 6.3.3. Ledged door**



## 2. Ledged and braced doors

This is an improved form of battend and ledged door. In this type of door two additional members are provided in the form of inclined braces as shown in (fig 12.4). The braces incline downwards towards the side on which the door is hung.



**Fig. 6.3.4. Ledged and braced doors**

### 3. Ledged and framed doors

The frame work of this type of door consists of two vertical members called stiles, three horizontal members known as ledges and vertical battens. Size of stiles should be 10 cm X 40 mm. This is considered to be superior in strength, durability and appearance to other two types of doors mentioned above.

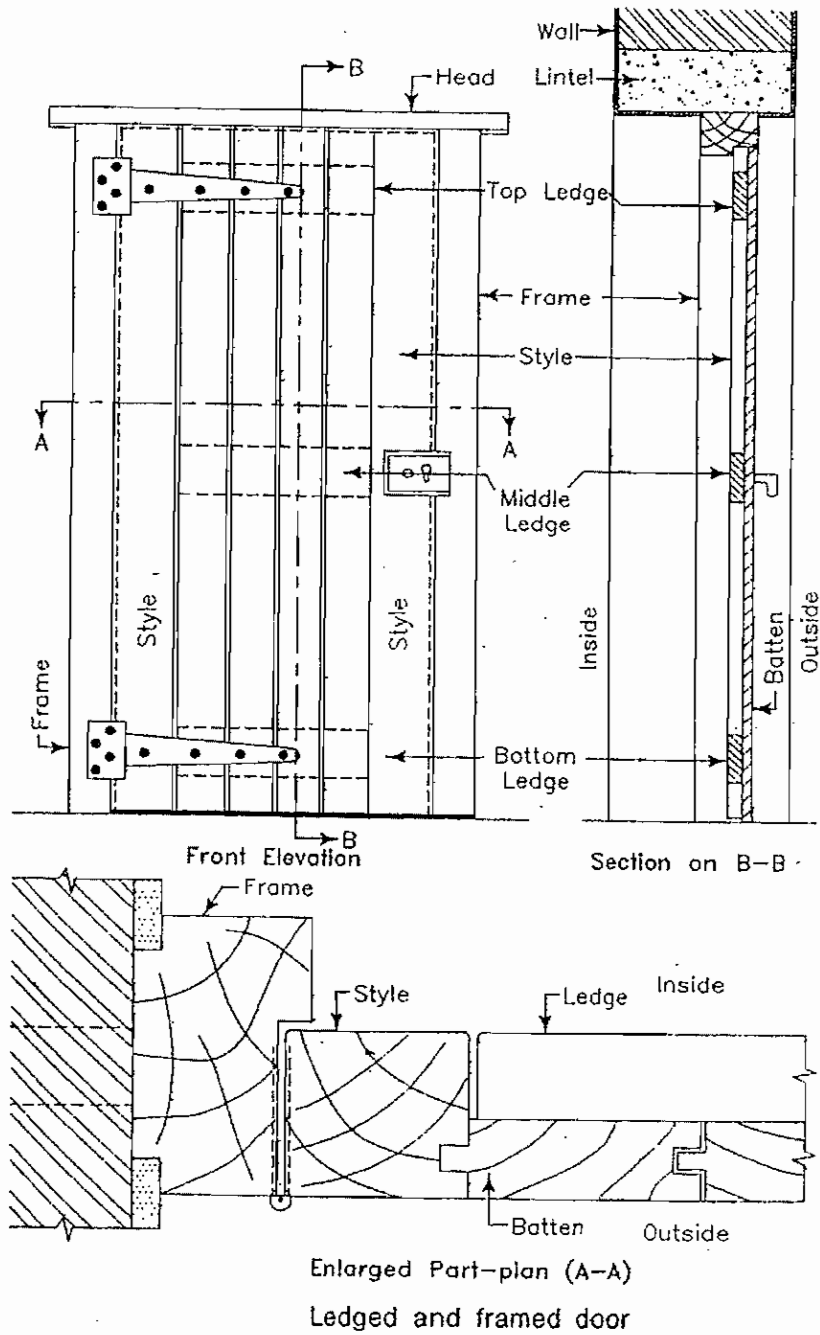

**Fig. 6.3.5. Ledged and framed doors**

#### 4. Ledged, braced and framed doors

This door consists of battens, ledges, braces and frames. It has more strength, durability and appearance. The braces are housed and inclined towards the side on which the door is hung.

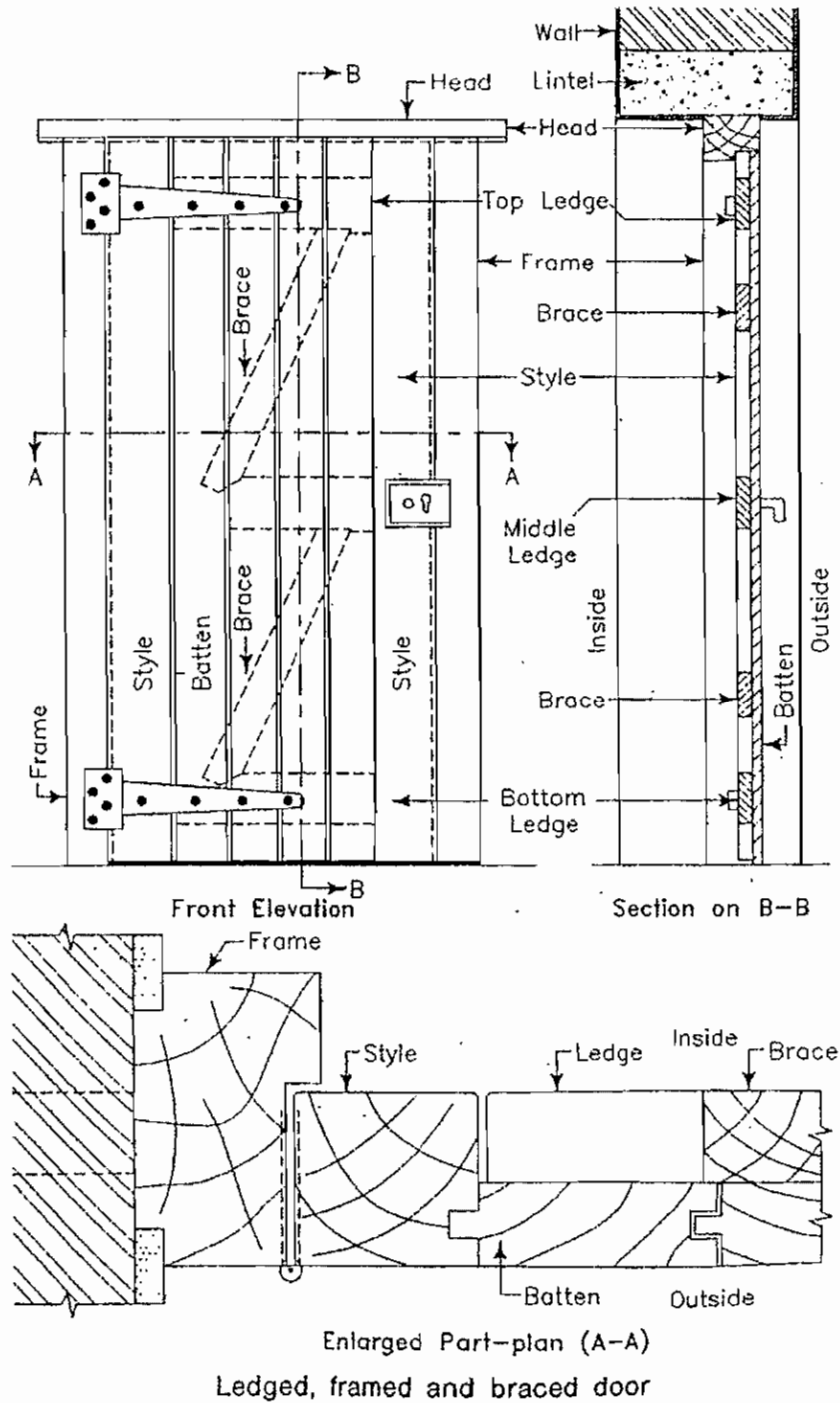

**Fig. 6.3.6. Ledged, braced and framed doors**

## 5. Framed and Paneled Doors

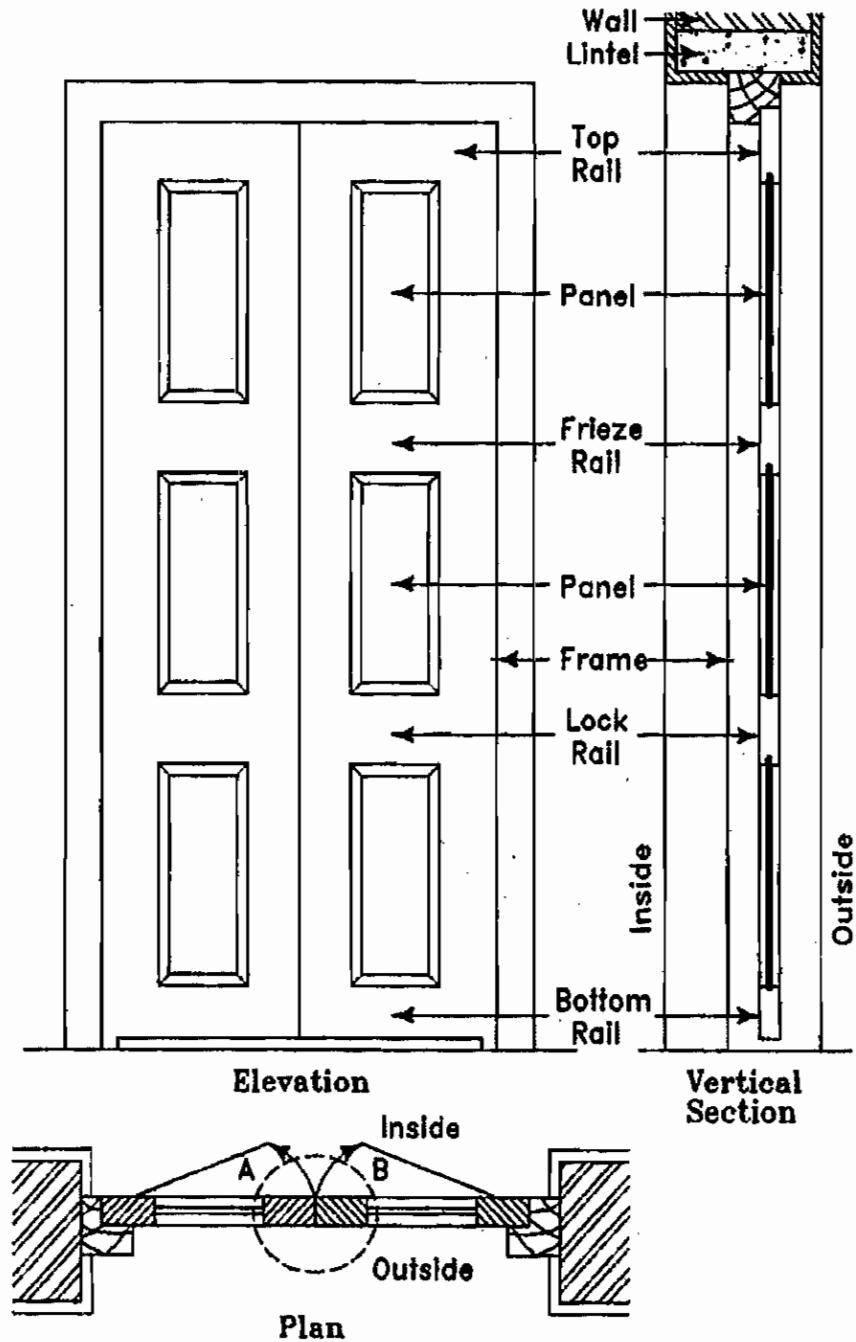

**Fig. 6.3.7. Framed and Paneled Doors**

This type of door is commonly provided in all types of buildings. This door consists of timber frame work of stiles and rails which are grooved on the inside to receive one or more panels. The number of panels and type of panels should be selected according to the places used. The thickness of shutter should be 30 mm 40 mm and thickness of panels should be 20 mm. the door may be single, double, three, four or six paneled and so on. This should have good appearance.

## 6. Glazed doors

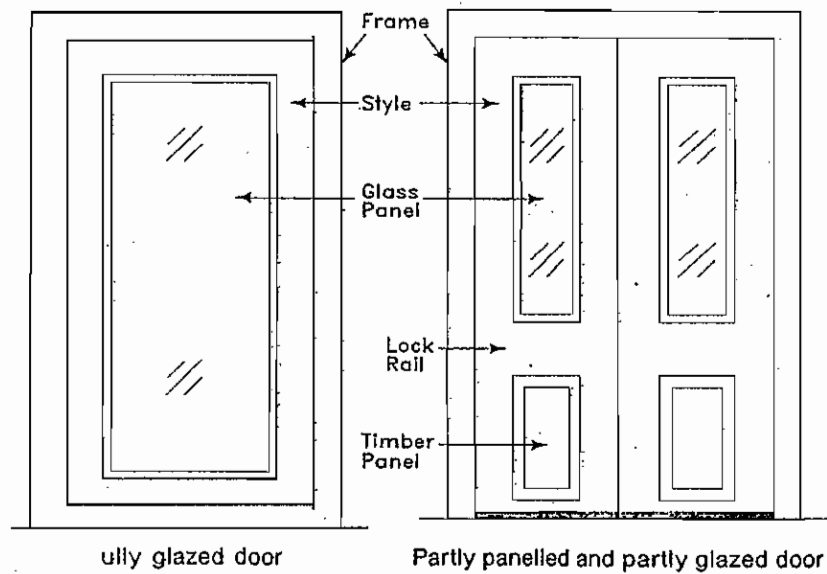

**Fig. 6.3.8. Glazed doors**

This type of door is used in residential as well as public buildings like hospitals, schools or colleges etc. with a view to supplement the natural lighting provided by windows. They can be glazed fully or partly. The glass should be fitted by using putty with frames.

## 7. Flush doors

Flush doors have pleasing appearance, Simple construction, high strength and durability and cost less. Flush doors can be divided in following types.

- (i) Solid core type flush door.
- (ii) Hollow core type flush door.

### (a) Solid core flush door

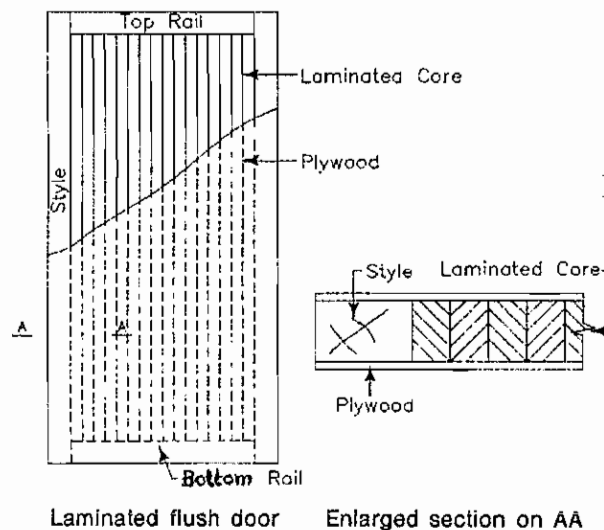
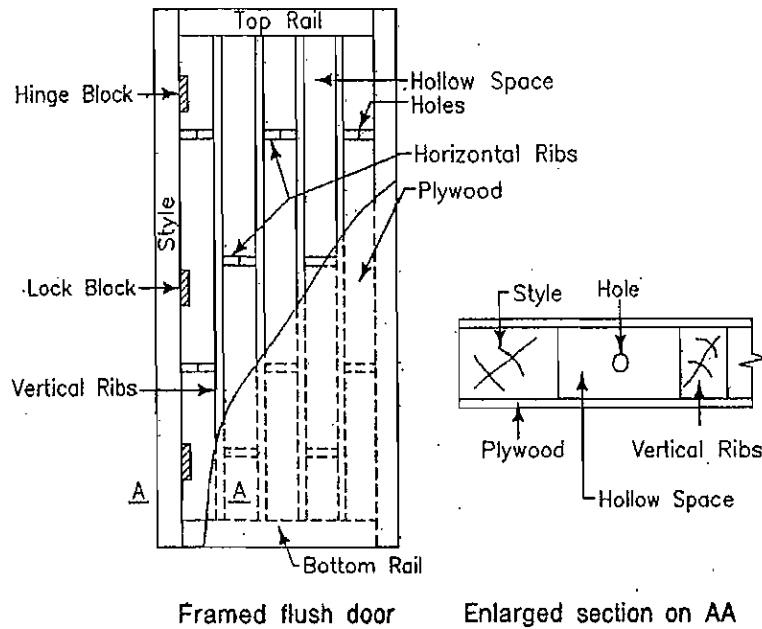

**Fig. 6.3.9. Flush door - Solid core**

The frame is made out of selected species of timber. It is necessary to provide hard wood lipping around the frame. The thickness of the shutter should be 30 mm.

**(b) Hollow core type flush door**

In this type the frame consists of stiles, top rail, bottom rails and minimum inter mediate rails. The space between stiles and the rails is divided by fixing wooden battens not less than 25 mm in width. The voids are equally distributed. The voids should be filled with work. Plywood sheets and face veneers are then glued under pressure on both faces of the core.



**Fig. 6.3.10. Flush door Hollow core**

**8. Louvered doors**

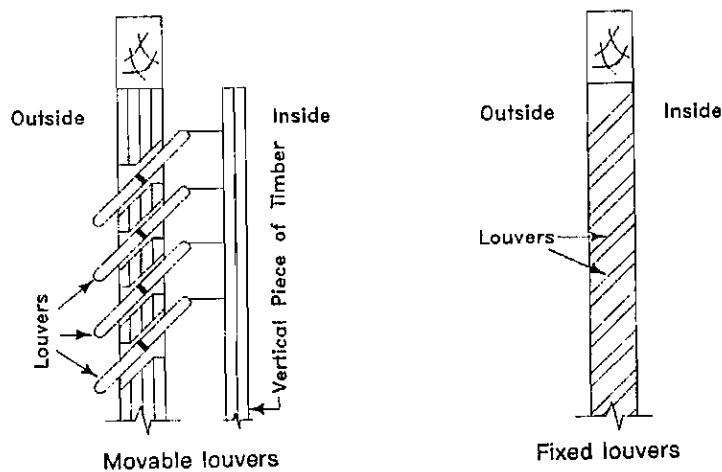

**Fig. 6.3.11. Louvered Doors**

In this type of doors the stiles of shutter are grooved to receive a series of louvers which may be of glass or wood. The louvers are set within the grooves in inclined position, so that they slope downward to the outside in order to run off the rain water and obstruct the horizontal vision at the same time. It may be fixed or pivoted. These are commonly used in bathrooms, W.C., Workshops, dressing rooms etc.

### 9. Collapsible Doors

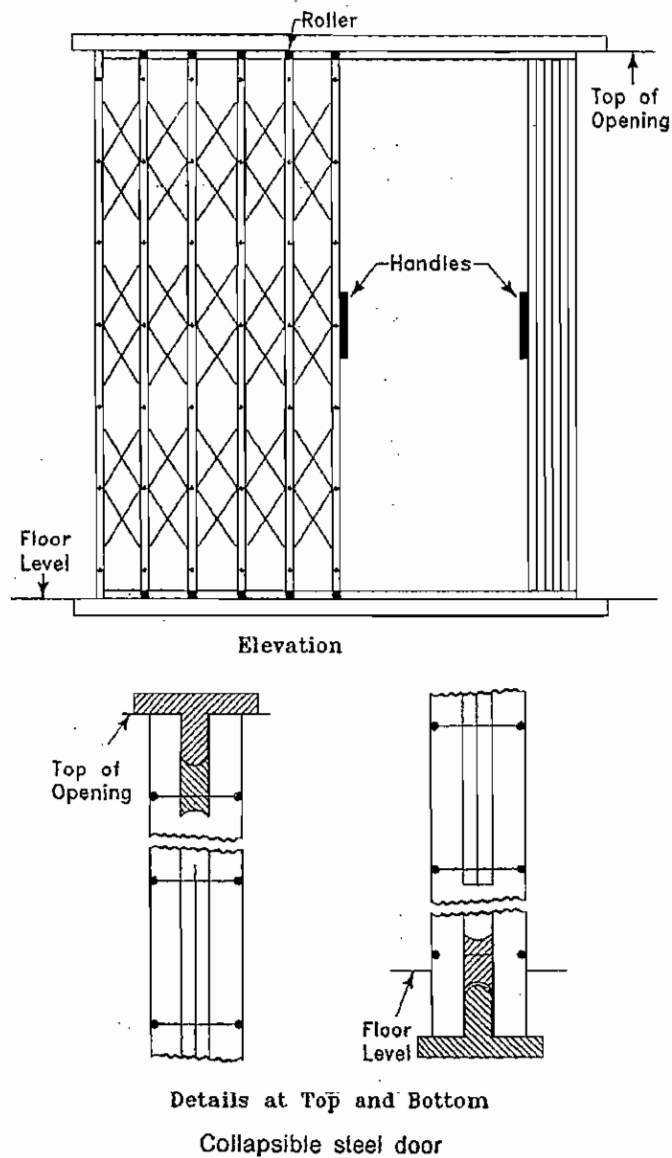

**Fig. 6.3.12. Collapsible Doors**

These doors are used for shops garages, public buildings, godowns etc, and in situations where width of opening is large. The door essentially consists of vertical double channels each 20 x 10 x 2 mm in size and spaced at 10 to 12 cm apart. These are braced with flat iron diagonals 20 mm wide and 5 mm thick,. The door shutter slides over roller mounted at its bottom and is held in position by the rails. This door is also used for residences to increase safety and protection.

## 10. Revolving doors

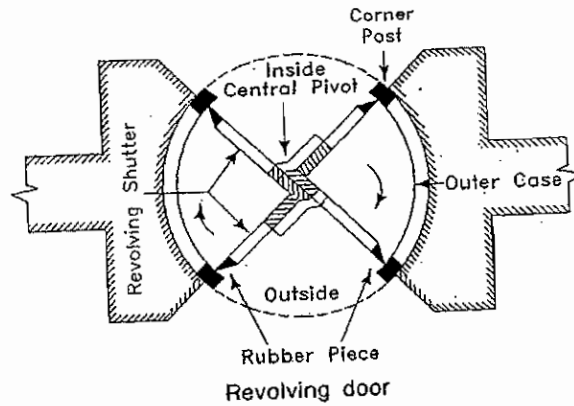

**Fig 6.3.13. Revolving door**

This door essentially consists of four leaves radially attached to a centrally placed mullion in a circular opening. The leaves and the mullion are enclosed in a vestibule. The leaves may be glazed, paneled or partly glazed; such doors are commonly provided in hotels, banks, offices and other such important public buildings.

## 11. Rolling doors

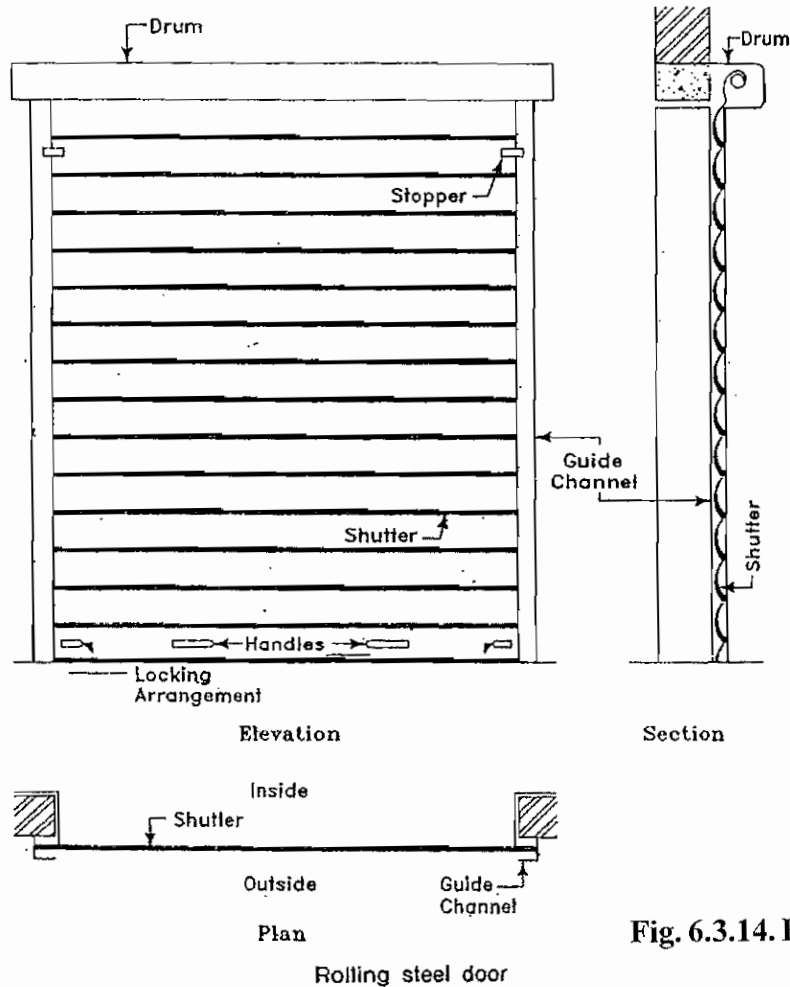

**Fig. 6.3.14. Rolling Door**



The shutter consists of thin steel slabs inter locked to each other and wiled upon specially designed pipe shaft mounted at the top of the opening. The door shutter travels in two vertical steel guide channels installed at either end of the opening. The shutter is counter balanced by means of helical spring enclosed in the drum. These are used for stores, shop fronts, factories and garages etc.

## 12. Sliding Doors

The door is provided with top and bottom guide rails or runners within which the shutters slide. The guide rails run past the opening for a distance equal to the width of the shutter so that when the door is required to be opened, the door shutter occupies a new position parallel to the wall face and clear off the opening. This type of door is suitable for good shops, sheds, godowns, officer, and garages.

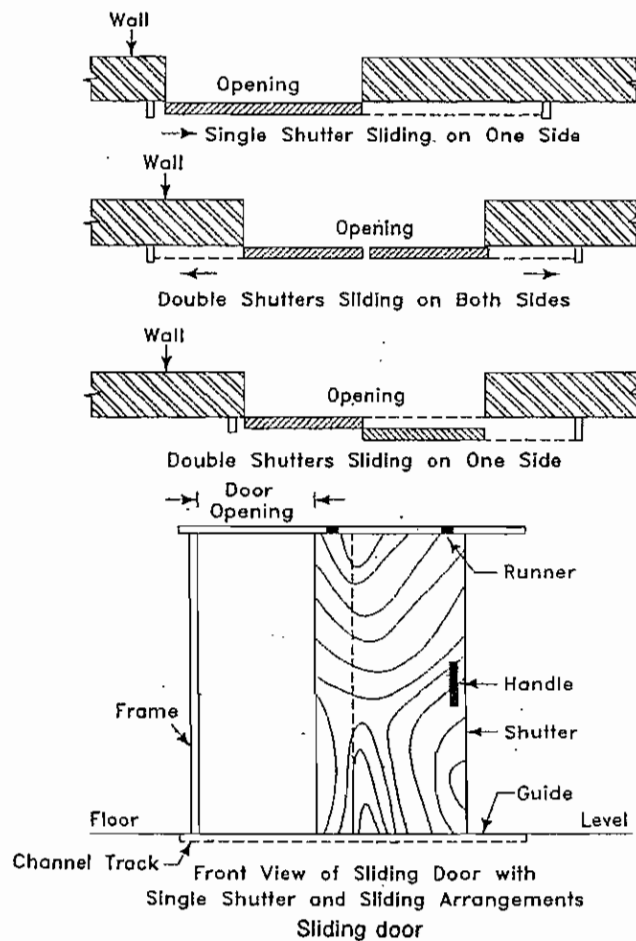

**Fig. 6.3.15. Sliding Doors**

### 12.3. TYPES OF WINDOWS

1. Dormer window
2. Louvered window
3. Bay window
4. Lantern window

5. Sky light window
6. Gable window
7. Corner window
8. Sliding window
9. Glazed or sash window

### 1. Dormer Window

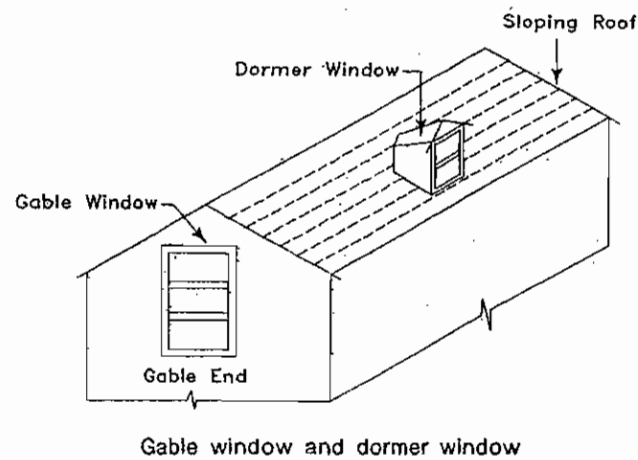

**Fig. 6.3.16. Dormer Window and Gable window**

It is a vertical window built in the sloping side of a pitched roof. This window is provided to achieve proper ventilation and lighting below the roof.

### 2. Louvered Window

In this type of window the stiles of shutter are grooved to receive a series of louvers. The louvers are set within the grooves in inclined position so that they slope downward to the outside in order to obstruct the horizontal vision. Louvers should be fixed or pivoted. Mostly used in bathrooms and toilet.

### 3. Bay Window

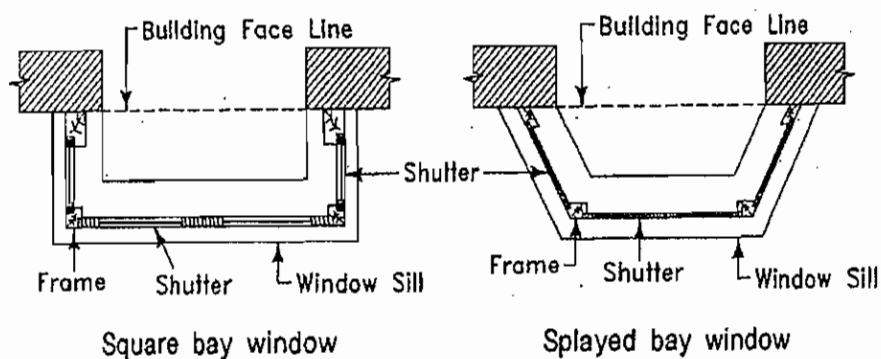

**Fig. 6.3.17. Bay Window**

A window projecting out ward from the walls of a room is termed as a bay window. Bay window may be square, rectangular or polygonal in plan and it is introduced with a view to provide an increased area of opening for admittance of light and ventilation.

#### 4. Lantern Window

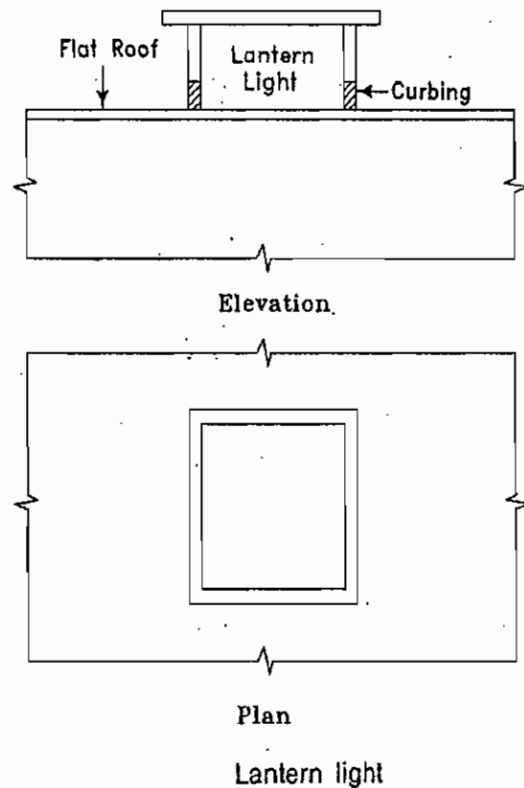

**Fig. 6.3.18. Lantern Window**

If the light from the windows on the walls is not enough, windows are provided on the roof also. These are called as lantern window. It should be square or rectangular in shape.

#### 5. Skylight Win

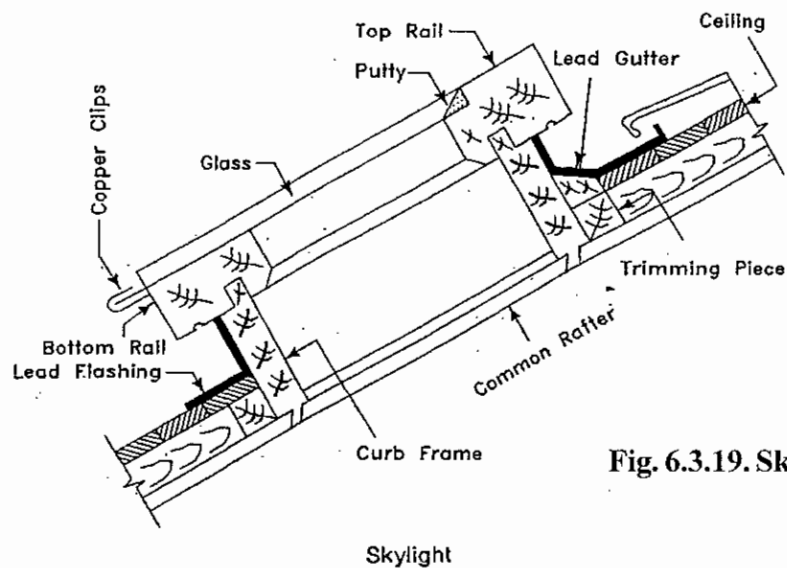

**Fig. 6.3.19. Skylight Window**

Skylight

This is a type of fixed window provided on the sloping surface of a pitched roof. The frame work of skylight supporting the glass panels. This type of windows are provided to get one more light.

### 6. Gable Window

The window provided in the gable end of a pitched roof is known as gable window.

### 7. Corner Window

This type of window is essentially located in the corner of a room. It serves an architectural features for improving the elevation of the building.

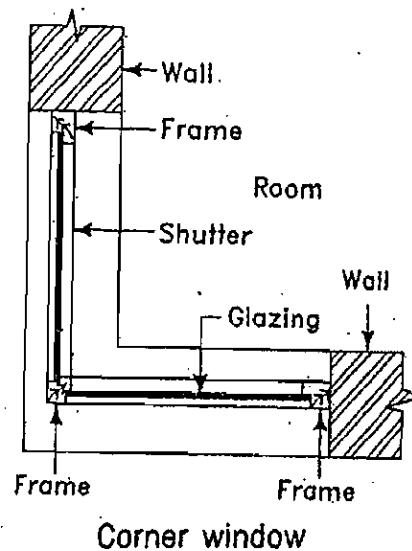

Fig. 6.3.20. Corner Window

### 8. Sliding Window

In this type of window the shutters move on the roller bearing and can slide either horizontally or vertically.

### 9. Glazed Window

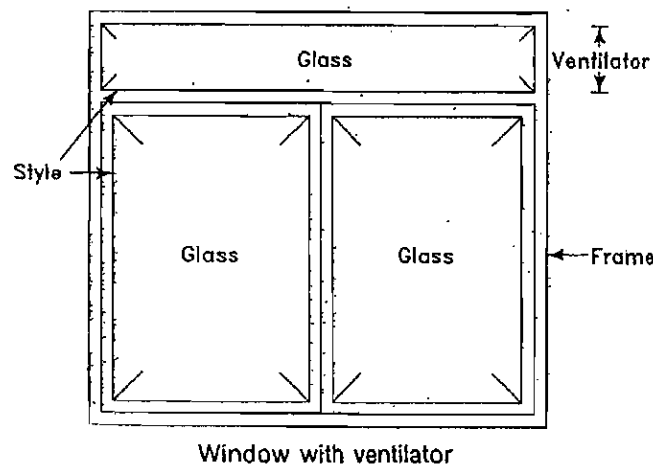

Fig. 6.3.21. Glazed Window

The shutters of this window should be glass. The glass panels are secured in either by putty or by small fillets known as glazing beads. These windows should also be giving light when the window is closed.

### **6.3.7. FIXTURES FOR DOORS AND WINDOWS**

#### **Hinges**

##### **1) Back flap hinge**

It should be used when the thickness of door shutter is less.

##### **2) Butt hinge**

It is the commonly used type of hinge.

##### **3) Counter flap hinge**

While closing the door the two parts of the door should join together.

##### **4) Garnet hinge**

It is used in ledged and braced doors.

##### **5) Rising butt hinge**

It increases height by 10 mm when opening.

##### **6) Strap hinge**

It is used for heavy doors.

#### **Bolts**

##### **1. Aldrop bolt**

It is used in eternal doors of the buildings.

##### **2. Barrel bolt**

These are fixed in the backside of doors.

##### **3. Latch**

Used for all types of doors and windows.

##### **4. Hasp and staple bolt**

Used for external doors.

##### **5. Tower bolt**

It is nearly the same as barrel bolt. But three or two rings used instead of the barrel.

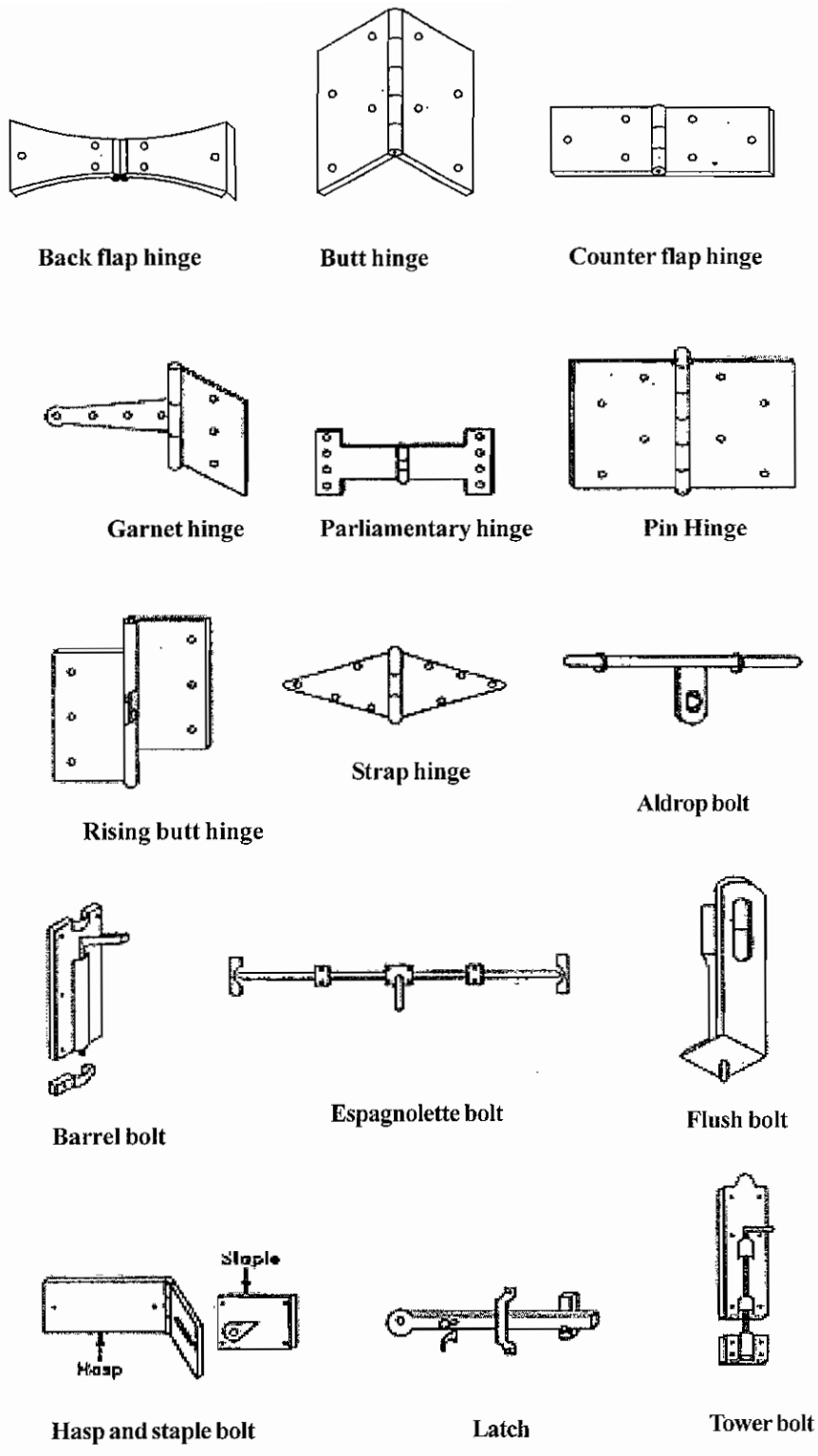

**Fig. 6.3.22. Hinges and Bolts**

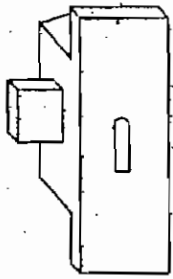

Cupboard lock

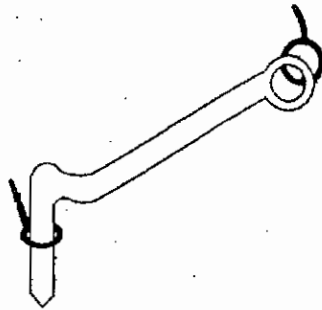

Hook and eye

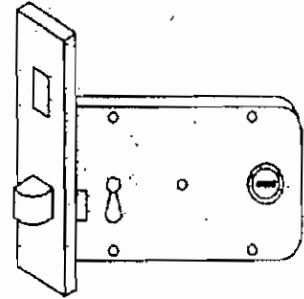

Mortise lock

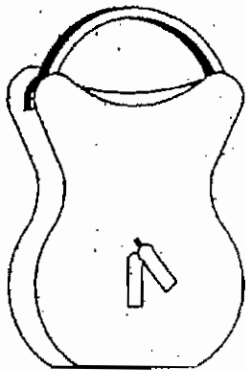

Pad lock

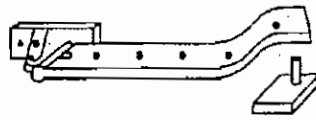

Peg stay

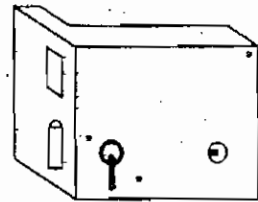

Rim lock



Bow handle

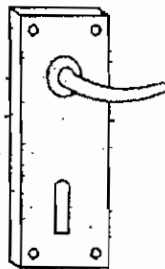

Lever handle

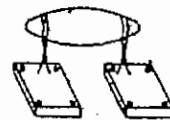

Wardrobe handle

**Fig. 6.3.23. Locks and Handles**

## **Locks**

### **1. Cup-board lock**

Used for small doors

### **2. Hooke and eye**

To keep the windows in open condition these bolts are used.

### **3. Mortise lock**

To lock the doors from out side of the rooms.

### **4. Pad lock**

These are used together with aldrap bolt.



## QUESTIONS

### PART-A

#### I. Choose the best answer and write

- 1) Terms used in window  
a) style                      b) joint                      c) Housing                      d) Grooving
- 2) Shape of providing BAY window  
a) circle                      b) sphere                      c) triangle                      d) square
- 3) Hinge used in ordinary window  
a) Butt hinge                      b) strap hinge                      c) Patlock                      d) Garnet hinge.
- 4) While opening the door rising Butt Hinge are used to raise the door.  
a) 5 mm                      b) 20 mm                      c) 30 mm                      d) 10 mm
- 5) Which of the following is alike Tower bolt.  
a) Host                      b) Barel                      c) Ordinary                      d) Aldrop
- 6) When Aldrop bolt is fixed which of the following is used  
a) Mortise                      b) pat lock                      c) cup board lock                      d) Hook and eye
- 7) The nature of door with Boards and Panels  
a) Not breakable                      b) Weight is not high                      c) will not shrink                      d) Not wider

### PART-B

#### II. Answer in one (or) two sentences

- 1) What is style?
- 2) What is Top Rail?
- 3) What is lower rail?
- 4) What is a Panel?
- 5) Write the types of Doors.
- 6) Write the types of flush doors.
- 7) What is strap Hinge?
- 8) In which portion of the door Barel Bolt is provided.
- 9) What is a Pat Lock?
- 10) What is a corner Window?
- 11) Where Hinges are fixed in Doors.

### **PART-C**

#### **III. Answer in one (or) two sentences:**

- 1) What is a door?
- 2) Write any 4 types of doors.
- 3) What is a panel door?
- 4) Write 3 types of window.
- 5) Draw a neat sketch of Glazed window.
- 6) What is a window?
- 7) What is the use of a Ultra Bolt.
- 8) What is the use of cupboard lock.
- 9) Define Door Frame.
- 10) Define Top Rail and Lock Rail.

### **PART-D**

#### **IV. Answer in shortly**

- 1) Define the places where the doors and windows are fixed.
- 2) Write any five terms used in Doors and windows and define them.
- 3) What is the difference between ledged doors and ledged and braced doors?
- 4) Draw the sketch of a paneled door and illustrate the parts.
- 5) What is the difference between lantern window and skylight window?

### **PART-E**

#### **V. Answer in Detail**

- 1) Write the types of Doors and windows and explain any three of them.
- 2) Explain the hinges, bolts and locks used in Doors and Windows?
- 3) Define any three windows with sketch.

# UNIT VII

## 7.1. STAIRS

### 7.1.1. INTRODUCTION

A stair may be defined as series of steps suitably arranged for the purpose of connecting different floors of a building.

### 7.1.2. Terms used in stair case

#### Tread

The horizontal upper part of a step on which foot is placed in ascending or descending stair way.

#### Riser

The vertical portion of a step.

#### Rise

It is the vertical distance between the successive treads.

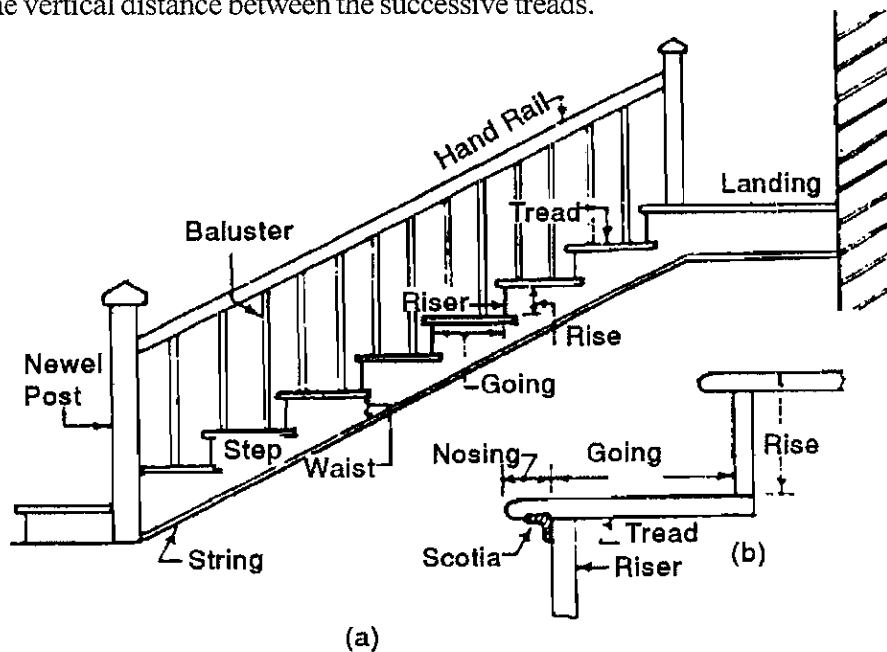

Fig. 7.1.1. Terms in stair case

#### Landing

A platform or resting place provided between two flights.

#### Flight

A series of steps without any platform, break or landing in their direction.

#### Going

The run of a step in a stair the width of the tread between two successive risers.

## Nosing

The outer projecting edge of a tread is termed as nosing.

## Line of nosing

It is an imaginary line touching the nosing of each tread.

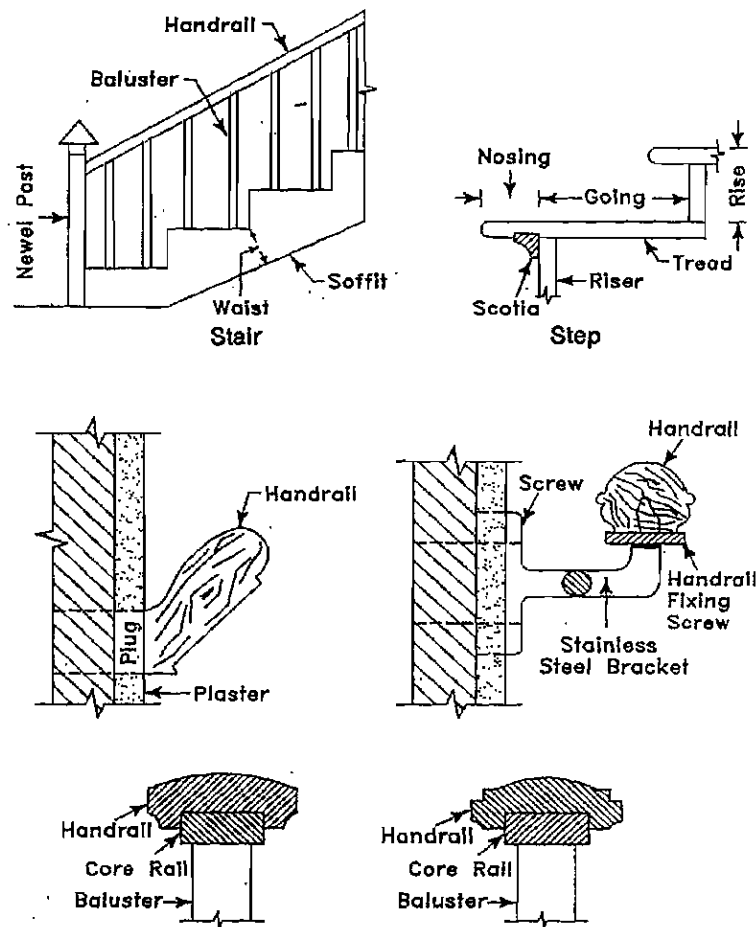

Fig. 7.1.2. Terms used in stair case

## Hand rail

They are provided to render assistance in negotiating a stair way.

## Newel post

It is a post supporting the hand rails

## Stringer

These are the sloping wooden or concrete members providing support for the steps.

## Windows

These are tapering steps which are provided for changing the direction of a stair.

## Baluster

It is a wooden, metal or masonry vertical member supporting a hand rail.

### 7.1.3. LOCATION OF STAIR CASE

The location of stairs in a building requires care full consideration. In the advent of fire or any such calamity, stairs provide the only means of communication and as such they are so located as to serve the purpose for which they are provided. In public building, it should be located near the main entrance and in residential building it should be placed centrally so as to provide easy access from all the rooms and to maintain privacy at the same time.

### 7.1.4. TYPES OF STAIRS

**I. The stair of different materials here been given below.**

- 1) Brick stairs.
- 2) Wooden stairs
- 3) Stone stairs
- 4) Steel stairs
- 5) Concrete stairs

**II. The different forms of stairs may be classified under the following main heads.**

- 1) Dog legged stairs
- 2) Open well stairs
- 3) Circular stairs
- 4) Bifurcated stairs
- 5) Geometrical stairs
- 6) Straight stairs

#### **Dog legged stairs**

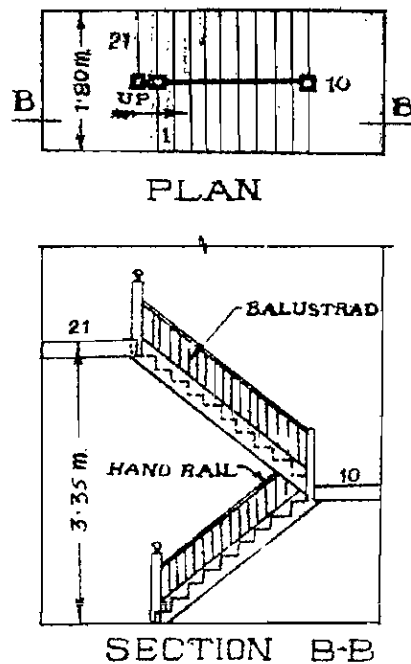

**Fig 7.1.3 Dog legged stairs**

It consists of two straight flights of steps with abrupt turn between them. Usually, a level landing is placed across the two flights at the change of direction. This type of stair is useful where the width of the stair case hall is just sufficient to accommodate two widths of stair.

### Open well stairs

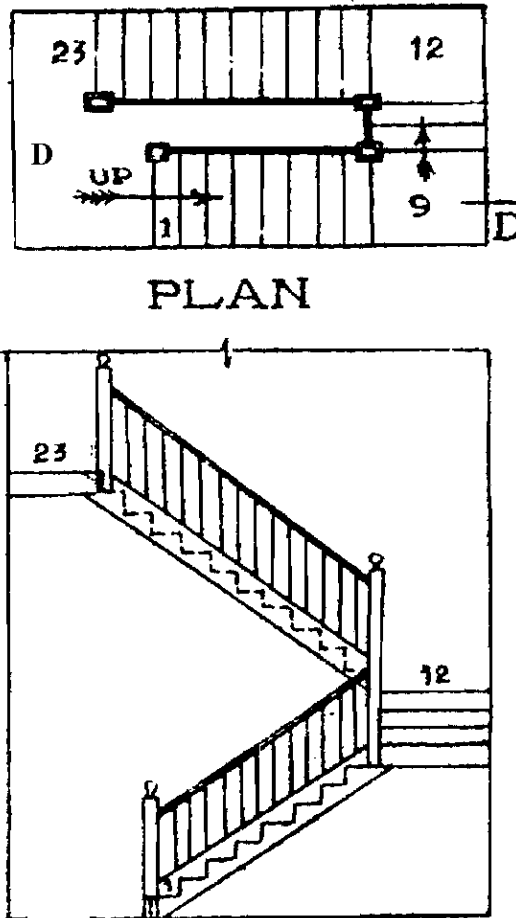
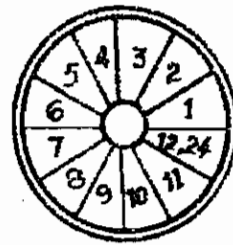
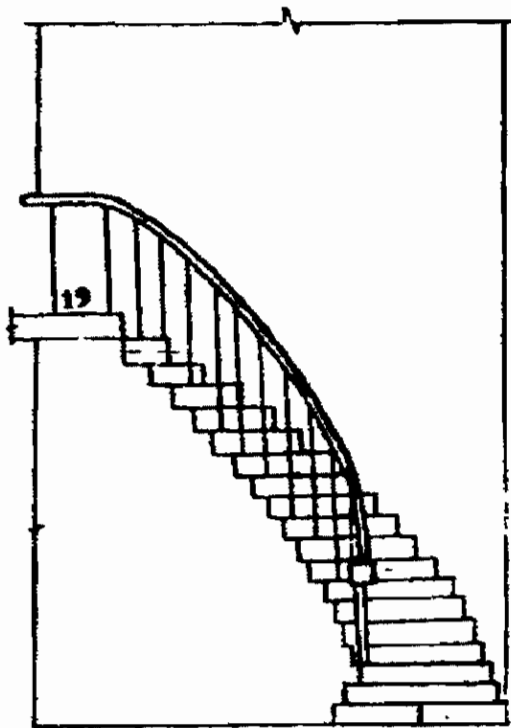
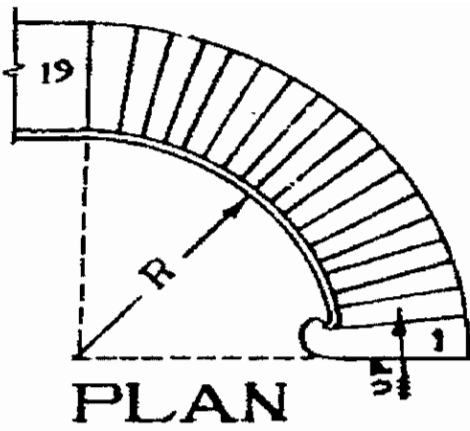

Fig 7.1.4. Open well stairs

It consists of two or more straight flight arranged in such a manner that a clear space called a “well” occurs between the flights. The well should be rectangular or curved in shape.

### Circular stairs or Spiral stairs

Circular stair is commonly provided at the back side of building for rendering access to its various floors for service purposes. The circular stairs are commonly constructed in R.C.C. Steps radiate from a well hole, in the form of winders.



R = 15 CM.  
 T = 27 CM.  
 W = 90 CM.

PLAN

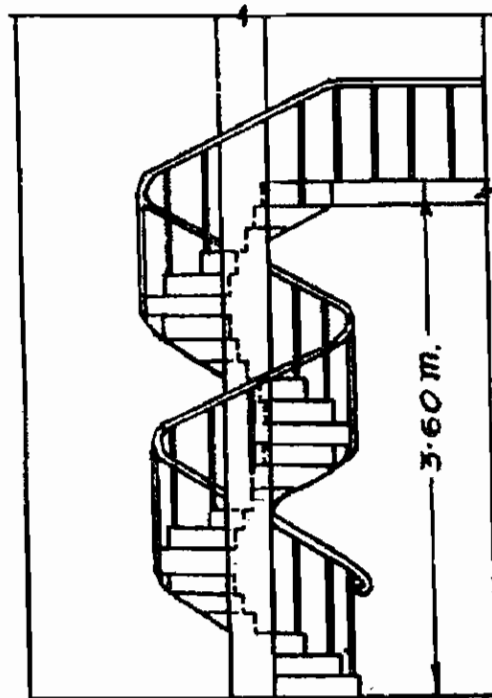

ELEVATION

Fig. 7.1.5. Circular and spiral stairs

### Bifurcated stairs

This type of stair is suitably provided in modern aristocratic public buildings. In this type of stair the flights are so arranged that there is a wide flight at the start which is sub divided into narrow flights at the mid landing.

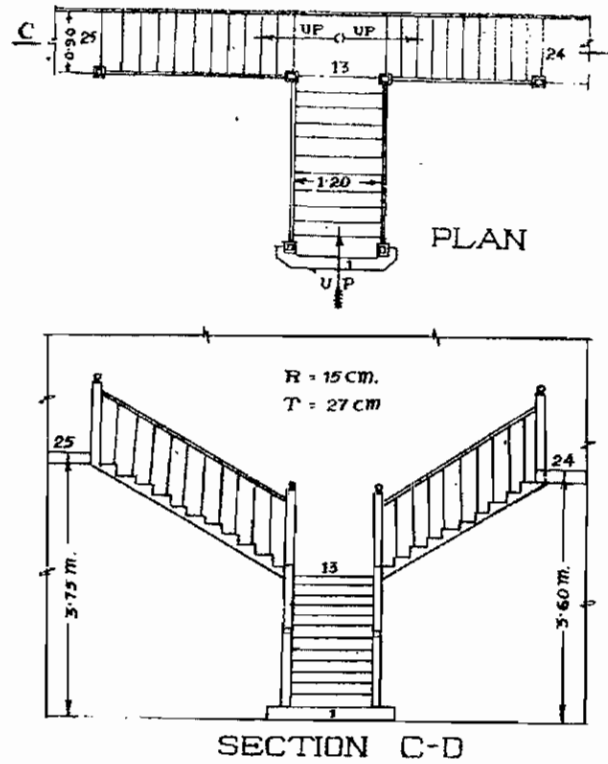

Fig. 7.1.6. Bifurcated stairs

### Geometrical stairs

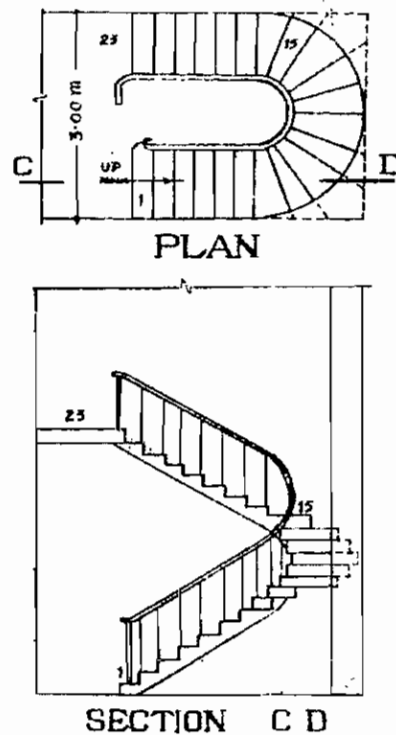

Fig. 7.1.7. Geometrical stairs



This is similar to the open-newell stair with the difference that the open well between the flights is curved. In this form of stair, the change in direction is obtained through winders. It is classified in to half turn stairs and quarter turn stairs.

### Straight Stairs

In this form of stair all the steps rise in the same direction. If the ascending is steep, the straight flight may be broken at an intermediate landing

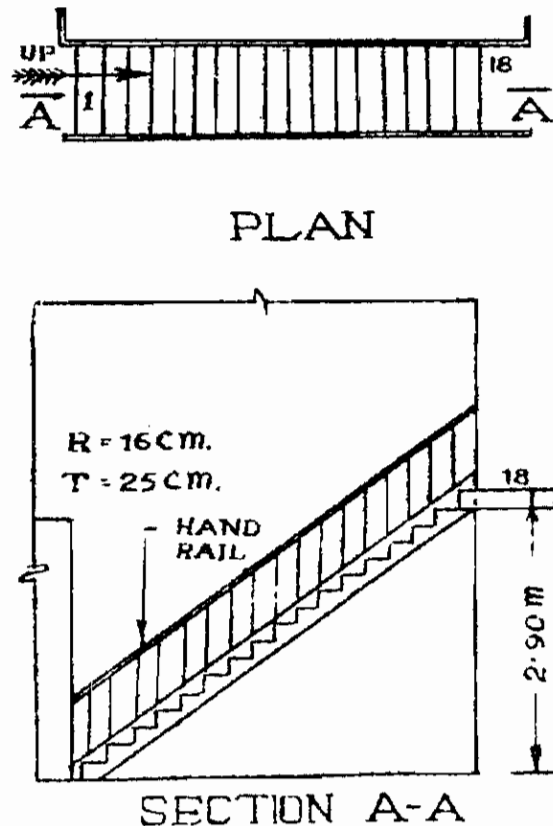

Fig. 7.1.8. Straight Stairs

### 7.1.5. REQUIREMENTS OF A GOOD STAIR

- 1) The width of the stair should be minimum 100 cm
- 2) The tread should not be less than 25 cm.
- 3) The riser should be maximum 20 cm
- 4) The number of steps should not exceed 12 in a flight.
- 5) The pitch of the stair should be minimum  $25^{\circ}$  and maximum  $40^{\circ}$
- 6) The width of the landing should not be less than the width of the stair.
- 7) It should be so located that sufficient light and ventilation is ensured in the stair way. If possible it should be located centrally so as to be easily accessible from the different corners of the building.

### 7.1.6. ESCALATORS

A power driven inclined continuous stair way used for raising or lowering passengers is called an escalator. The stairway has continuous operation without the need for operators. The main component of an escalator is a steel trussed frame work, handrails and an endless belt of steps. In using an escalator one has just to stand on a step and it is the moving step that takes him up or down. Escalators are normally used in pairs. Out of the two one is used of carrying people up and the other one is used for carrying people down. Escalators are recommended in places where movement of large number of people at a controlled rate in the minimum available space is involved. Eg in big departmental stores, exhibitions, railway stations air ports etc.

#### QUESTIONS

##### PART-A

##### I. Choose the best answer and write:

- 1) The vertical portion between the two tread
  - a) Landing
  - b) Nosing
  - c) Going
  - d) Riser
- 2) The vertical part fixed to resist the hand rail
  - a) Winders
  - b) stringer
  - c) Baluster
  - d) flight
- 3) The minimum size of tread of a step
  - a) 15 cm
  - b) 25 cm
  - c) 100 cm
  - d) 45 cm
- 4) When more than 12 steps in a row the part provided in the middle.
  - a) Riser
  - b) Landing
  - c) Tread
  - d) Nosing
- 5) Shape of bridge provided with Escalators.
  - a) Straight
  - b) Inclined
  - c) Flat
  - d) Lengthy
- 6) Minimum width of landing should be equal to the width of
  - a) floor
  - b) wall
  - c) steps
  - d) pillar
- 7) This provision is not available in straight staircase
  - a) Winder
  - b) Newel post
  - c) hand rail
  - d) Going
- 8) The steps operated by current
  - a) Modern
  - b) straight
  - c) circular
  - d) circular form
- 9) To change the direction landing is provided in the middle of these type of line
  - a) Four
  - b) Six
  - c) Three
  - d) Seven
- 10) The name of the projection extending outside of tread.
  - a) height
  - b) stringer
  - c) Baluster
  - d) Nosing

## **PART-B**

### **II. Answer in one (or) two sentences**

- 1) Where Landings are provided?
- 2) How the direction of curved staircase changed.
- 3) What should be the width of step in cm.,
- 4) Where escalators are used.
- 5) What is the name of the staircase without winders?
- 6) In which form open well stair case are provided.
- 7) What is the speed of Escalators?
- 8) How string is used in staircase?

## **PART-C**

### **III. Answer in one (or) two sentences**

- 1) What is the difference between Tread and rise.
- 2) Define Nosing and Nosing line.
- 3) Define Landing, Winders.
- 4) What is meant by staircase?
- 5) What are the types of staircases with regard to their shapes?
- 6) What are the types of staircases with regard to the materials used in construction?

## **PART-D**

### **IV. Answer in shortly**

- 1) What are the requirements of a good staircase?
- 2) Write about the escalators?
- 3) Draw the sketch of Dog legged staircase and illustrate the parts.
- 4) Draw any one staircase and illustrate the parts.

## **PART-E**

### **V. Answer in Detail**

- 1) Draw the sketch of a staircase and define some terms used.
- 2) Write the types of staircase define any two with sketch.

## **7.2. FLOORS AND FLOORING)**

### **7.2.1. INTRODUCTION**

Floor has the following two parts

- (i) A sub floor constructed by one by one of material such as concrete, brick or timber
- (ii) Floor finish or flooring above the sub floor (or) floor.

A strong part of the building constructed above the ground and below the roof is termed as floor. If a building has only ground floor, there will be only one floor. But in multistoried buildings the top of the roof slab is floor itself. The covering laid above the floor is termed as flooring.

### **7.2.2. QUALITY OF GOOD FLOORS**

- 1) It should be hard
- 2) It should be free from dampness
- 3) It should be durable
- 4) It should be easy to clean as far as possible it should be noiseless.
- 5) It should be free from dampness
- 6) It should be fire resistance.
- 7) It should have good appearance
- 8) It should not be very costly.

### **7.2.3. FACTORS WHICH GOVERN THE SELECTION OF TYPE OF FLOOR.**

- 1) The initial cost of floor
- 2) Durability and strength of floor
- 3) Appearance
- 4) Free from dampness, sound, heat
- 5) Low maintenance cost
- 6) Surface smoothness
- 7) Easily cleanable
- 8) It should be hard

The types of floor should be selected according to the above factors.

### **7.2.4. TYPES OF FLOORS**

Floors are classified into two types

- 1) Timber floors
- 2) Composite floors

## I. Timber floors

There are four types of timber floors.

- i) Basement or ground floor of timber.
- ii) Single joist timber floor
- iii) Double joist timber floor
- iv) Framed or triple joist timber floor

### i) Basement of ground floor of timber

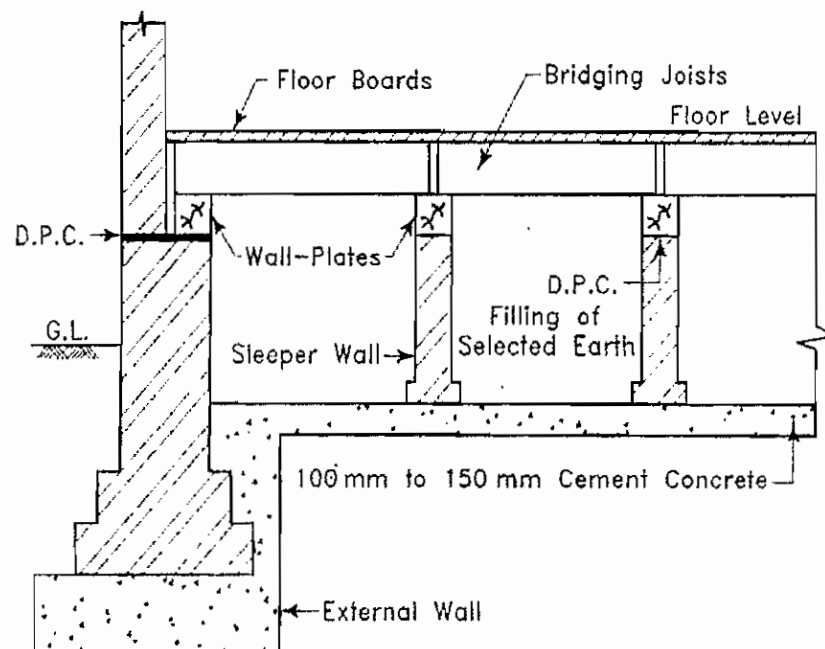

Basement or ground floor of timber

**Fig. 7.2.1. Basement or ground floor of timber**

This types of floors are used for dancing halls, auditoriums etc. It consists of boarding supported on timber joists called bridging joists which are nailed to wall plates at their ends and supported by intermediate walls called sleeper walls. A damp – proof course layer is laid immediately below the wall plates to prevent the rising of dampness. The hollow space between the flooring and the concrete is kept dry and fully ventilated.

### ii) Single joist timber floor

These floors are constructed by fixing boarding to wooden joists known as bridging joist spaced at 30 to 45 cm apart. The bridging joists are placed and nailed to timber wall plates fixed in the wall on either end. The span for single floor is limited to 3.6 m. If the span exceeds 2.4 m, strutting in sufficient space should be given.

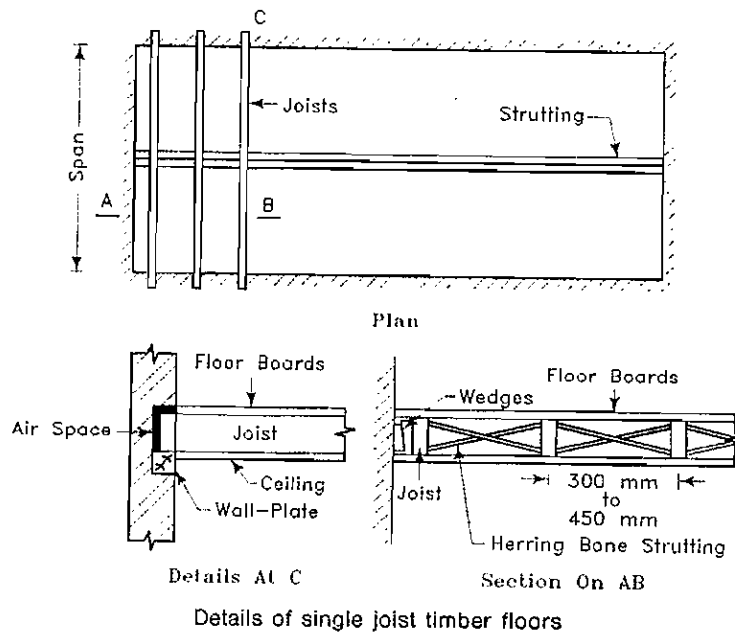

**Fig. 7.2.2. Single joist timber floor**

**iii) Double joist timber floor**

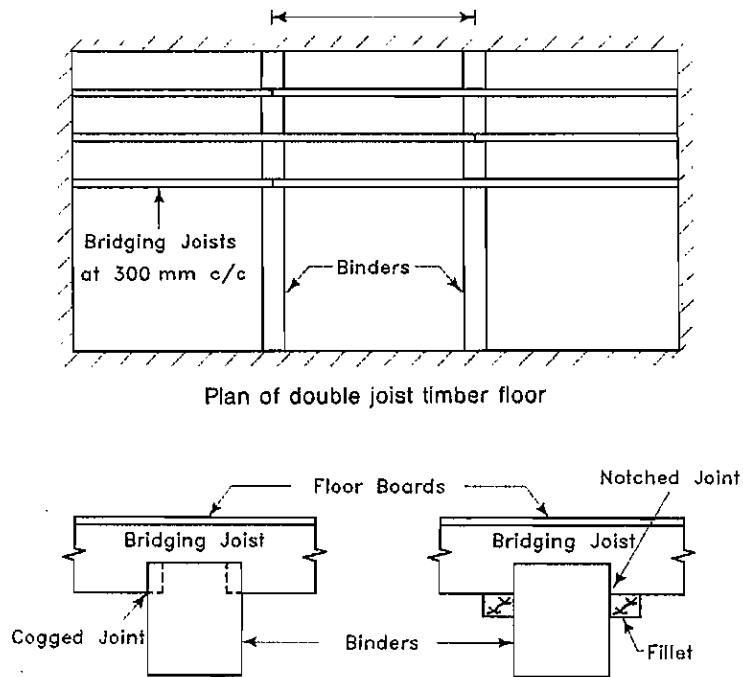

**Fig. 7.2.3. Double joist timber floor**

In double floors the bridging joists do not span the whole room, but rest on other joists placed at right angles to them. The joists are called binding joists or binders. This should be sound proof. The span of double floor is restricted to 7.5 m. These have increased depth which reduces the head room.

## II. Composite Floors

The floors constructed by more than one material in termed as composite floors. The advantages of composite floors.

- 1) These are fire resistant and sound proof.
- 2) This should be easily cleaned.
- 3) It is used in big spans.

### Types of composite floors

1. Double flagstone floors.
2. Filler joist floors
3. Jack arels floors.
4. R.C.C.Floors
5. Hollow block and rib floors.

### R.C.C.Floors

Concrete and steel should be used for this type of floors. R.C.C.Flooring has become very popular in these days. Though concrete is strong in compression it is extremely weak in tension. Steel is equally strong in tension and in compression. Thus the combination of concrete and steel has proved to be ideal for floor construction. R.C.C beams also constructed with R.C.C. Floor

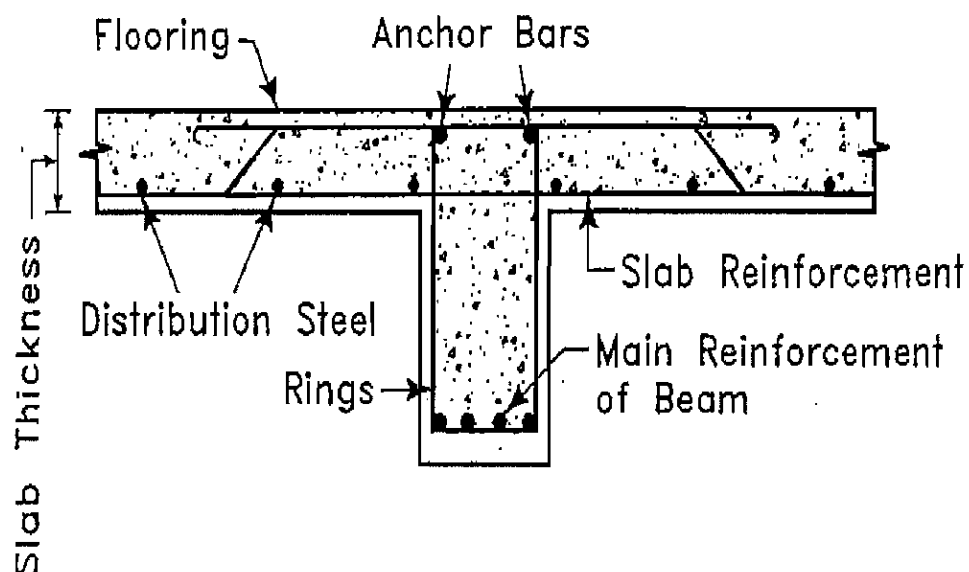

Typical R.C.C. floor

Fig. 7.2.4. R.C.C. Floor

R.C.C.Floors can be classified in the following two types (methods)

- 1) Pre-cast
- 2) Cast – in – site

When comparing with other floors, R.C.C.floors are

- i) Economical
- ii) Durable
- iii) Fire – proof
- iv) Easy to construct

### Hollow block and RIB Floors

It is a form of reinforced concrete floor slab construction. But the space between the ribs is often filled with hollow block made out of clay, fibre glass, P.V.C.or concrete.

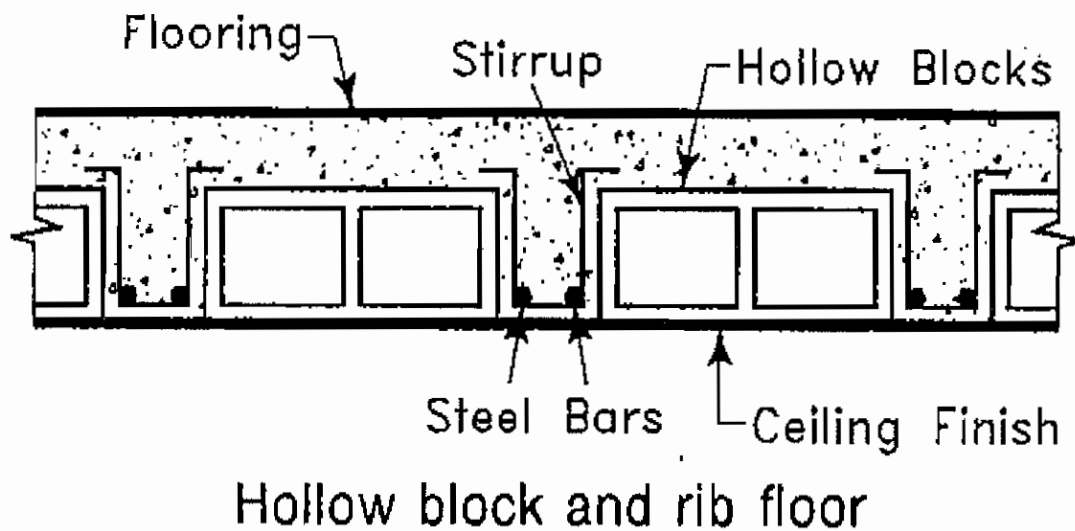

**Fig. 7.2.5. Hollow block and RIB Floors**

The advantages of ribbed slab construction can be summarized as under.

- a) Economical
- b) Fire resistant
- c) Sound proof
- d) Light weight



### 7.2.5. TYPES OF FLOORING ACCORDING TO THE MATERIALS USED

1. Mud flooring
2. Brick flooring
3. Concrete flooring
4. Ellis pattern flooring
5. Terrazzo flooring
6. Granolithic flooring
7. Asphalt flooring
8. Mosaic flooring
9. Wooden flooring(Timber flooring)
10. Stone slab flooring

#### 1. Mud flooring

In a topical country like India, Mud floors are commonly constructed in villages. They are cheap, hard fairly impervious, easy in construction and easy in maintenance. The method of its construction is very simple. Upon the prepared bed a 25 cm thick layer of selected moist earth is evenly spread out and is rammed well so as to get a consolidated thickness of about 15 cm. in order to prevent the formation of cracks after drying, chopped straw in small quantity is mixed with the moist earth before ramming. The floor is maintained by giving a thin cement cow – dung wash once or twice a week.

#### 2. Brick flooring

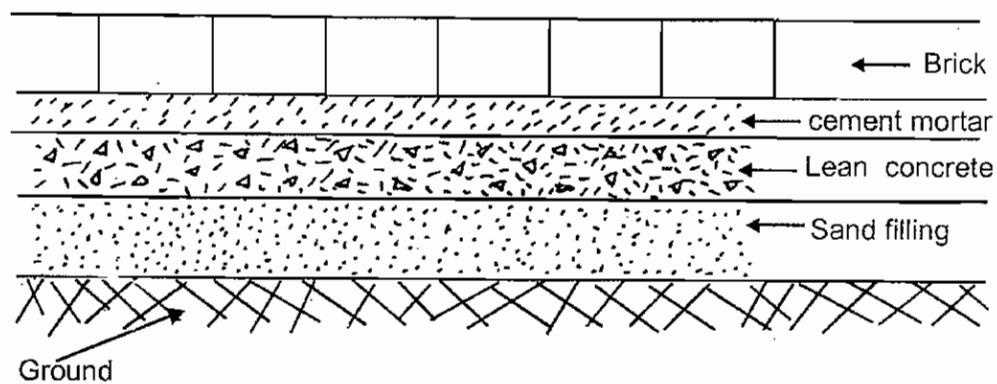

**Fig. 7.2.6. Brick Flooring**

The flooring may be done with brick laid on flat or on edge arranged in herring bone fashion or set at rightangles to the wall. The earth filling under floor is well compacted first and there after 10 to 15 cm thick of cement or lime concrete layer is laid over the entire area of floor. The bricks are laid on edge on 12mm thick mortar bed in such a manner that all the joints are full of mortar.

### 3. Cement concrete flooring

This type of flooring is commonly used both in residential as well as public buildings. The earth filling in plinth is consolidated thoroughly. The base concrete used under floors may be lime concrete or cement concrete to a thickness varying from 10 to 15 cm. when the base concrete has fully set and hardened, its surface is thoroughly cleaned and the entire area is divided in to rectangular or square panels of 1.25 m X 1.25 m size. The panels should be laid with C.C.1:2:4 is then laid in required thickness in one operation in the panels. The concrete is spread evenly by using a straight edge and the surface is thoroughly tamped and floated with wooden floats till the cream of the mortar comes at top. The surface is then smoothed and finally finished by means of steel trowels. The flooring should be cured for 15 days before use.

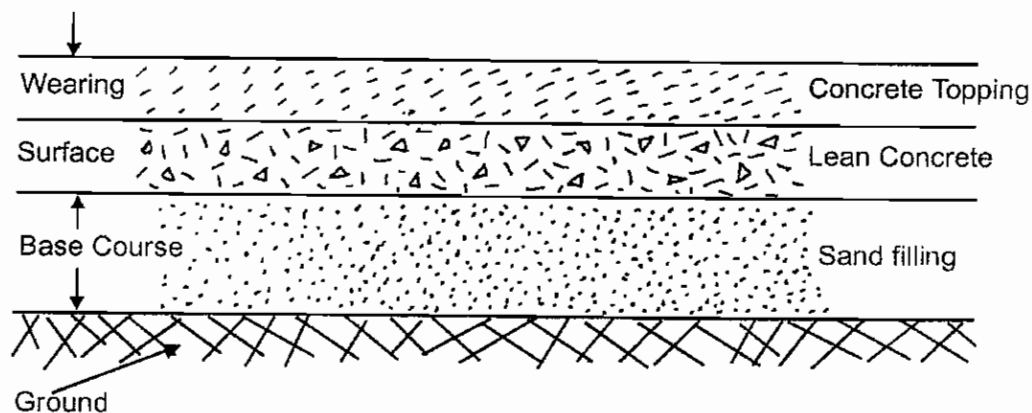

Fig. 7.2.7. Cement concrete flooring

### 4. Ellis pattern flooring

This floor should be laid by using C.C.1:3:6 of aggregates size 3 mm to 9 mm. the thickness of this floors should be 15 cm. above the concrete a topping of 20 mm thick should be given. This type of floors are largely used in office buildings, schools and public buildings.

### 5. Terrozo flooring

Terrozo is a concrete surface with special aggregate of marble chips mixed with white or coloured cement in proportion of 3 : 1 at first the base concrete should be laid. The concrete under layer is then spread, consolidated leveled and finished to a slightly rough surface. When the layer has hardened sufficiently, already prepared plastic terrazzo mixture is laid over the treated under layer and compacted by tamping or rolling. This should be cured for seven days and should be polished by floor polishing machines.

### 6. Granolithic flooring

It is a finishing coat provided over the concrete surface to form a hard, resistant to abrasion and durable flooring. In this flooring grading of aggregates is very important. Course aggregates from basalt or limestone or quartzite are suitably graded from 10 mm. The concrete mix is usually of 1:1:2 or 1:1:3. The granolithic concrete should be laid before the base concrete has set. The minimum thickness of finishing should be 13mm. After lying, the surface is tamped and floated with wooden floats and finally smoothed by means of steel trowel. This should be used for factories, workshops, schools, hospitals and garages.

## 7. Asphalt flooring

This type of floor is laid on the previously prepared concrete bed. The asphalt is broken into pieces and is put into an iron pot and is heated with fire upto the asphalt has melted. Grit is then gently added to the molten mass in the proportion of 2:1. This mixture is poured on the surface by means of iron ladle. The mixture is used immediately. It should be 10 mm thick in residences and office buildings and 20 mm to public buildings and 25 mm to factories.

### Advantages of asphalt floors

1. Water proof
2. Easily cleanable
3. Don't affected by acids.
4. There should be no cracks
5. Long durable

## 8. Mosaic flooring

Over the hard base concrete bed this floor should be laid. Concrete surface should be cleaned and cured. Above that c.m. 1:3 should be spread for 1 cm thick uniformly. Mosaic tiles should be laid with sufficient slope. These are laid with white or coloured cement. Then the floor should be cured. The flooring should be polished by using floor polishing machines.

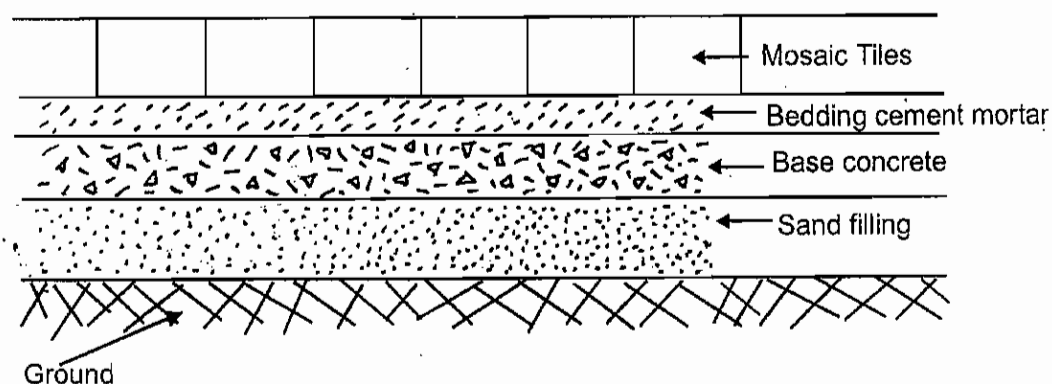
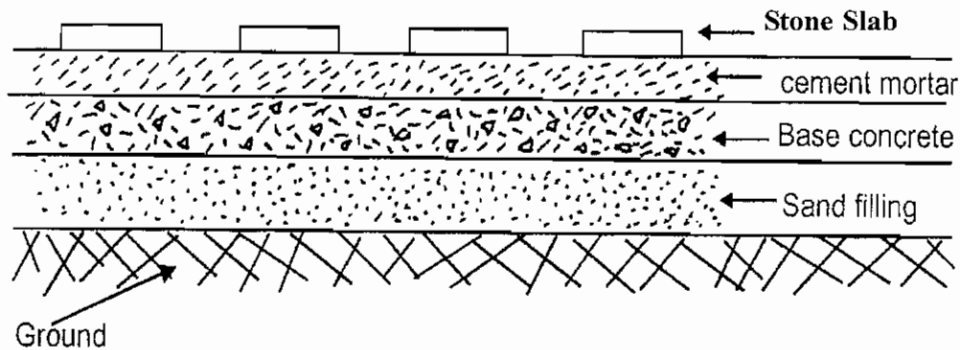

Fig. 7.2.8. Mosaic floor

## 9. Timber floorings

In hilly areas where the climate is damp and wood is easily available, wooden floors prove economical and as such are commonly used. The ground below the floor is covered with a 5 cm layer of cement concrete. Timber floors essentially consists of boarding supported on timber joists. The sleeper walls are honey combed.

## 10. Stone slab flooring



**Fig. 7.2.9. Stone slab flooring**

The stone slab for flooring may be square or rectangular with width not less than 38 cm and thickness of 2 to 4 cm. Stone slabs are laid on 20 to 25 mm thick layer bed of mortar. A slope of 1 to 40 is necessary to be given in stone slab flooring for proper drainage. It is hard, durable and resistance to wear and tear and as such is used in workshops, motor-sheds and godowns.

### 7.2.6. FLOOR FINISHING AND FLOOR COVERING

Floor finishes and floor covering are used for appearance and protection for the floors. The following materials are used for floor finishing.

1. Cuddappa slab
2. Glazed tiles
3. Rubber tiles
4. Plastic tiles

#### 1. Cuddappa slab

Sharp edged, square or rectangular shaped cuddappa slabs are used for floor finish. The bottom side of cuddappa slabs are rough and the top and edges should be well dressed. These slabs are laid by rising c.m. 1:3 with a joint thickness of 5mm.

#### 2. Glazed tiles

These tiles are fitted over strong cement concrete floors. The top of the concrete surface should be rough and cement mortar layer should be laid. Cement mortar should also be applied at the bottom of tiles and are laid. The joint thickness should be minimum.

#### 3. Rubber tiles

This type of flooring is used in residential buildings like offices, hospitals, schools etc. these are suitable for concrete floor and timber floors. These are sound proof and can got in several colours.

#### 4. Plastic tiles

These are laid over concrete or timber floors. These are heated and pasted on the floor. This should be of 225 mm width and 3mm thickness. These are not affected by greese and acids.

#### 7.2.7. FLOOR COVERING

The following materials are used for floor covering.

##### 1. Plywood boards

This boards are fitted on timber floors. The sides should be nailed.

##### 2. Cork sheet and cork tiles

This sheets are also used above timber and concrete floors. Cork sheets are available in 1.8 m width and 13 to 30 m length. Cork tiles should be of 450 mm width and 900 mm length and thickness of 6,8,10,14 mm. The surface should be flat. It is long durable, good appearance and in many colours.

##### 3. Linoleum

It is a covering laid over wooden or concrete floors to enhance its appearance. It is available in varities of colours both in plain and printed form. It is mostly sold in rolls. These are mostly used in residences, public buildings, trains, ships and shops.

##### 4. Mats

These are manufactured from natural or artificial fibers. Wood wool and Cotton are natural fibers, Cellulose, Nylon, Polyester are artificial fibers. It should not be slip.

### QUESTIONS

#### Part-A

#### Choose the best answer and write

- 1) Good requirement of a floor
  - a) Planned
  - b) strong
  - c) Hard
  - d) mild
- 2) Types of floors
  - a) four
  - b) two
  - c) one
  - d) three
- 3) When RCC floors are required they are provided with
  - a) stones
  - b) slabs
  - c) Rods
  - d) Trees
- 4) If we have to fix smooth tiles its condition should be
  - a) Hard
  - b) Rough
  - c) mild
  - d) strong
- 5) The ply wood Board are fixed in this floor
  - a) RCC floor
  - b) composite floor
  - c) Timber floor
  - d) Rib floor

- 6) Types of R.C.C. floor  
a) four                      b) five                      c) three                      d) two
- 7) Cork floor and cork tile are respectively in length  
a) 12 m to 20 m              b) 13 m to 30 m              c) 14 m to 50 m              d) 15 m to 4 cm
- 8) Shape of linoleum  
a) circle                      b) square                      c) Rectangle                      d) Length
- 9) Natural carpets fibre are alike the fibre of  
a) Mango fibre              b) cotton fibre              c) Tak fibre                      d) Jack fibre
- 10) The condition in which Mosaic floors are provided on concrete floor  
a) Hard                      b) strong                      c) light                      d) Tough

### **PART-B**

#### **II. Answer in one (or) two sentences**

- 1) What should be the thickness of Brick floor.
- 2) In what ratio cement concrete floors are laid?
- 3) For how many days terrazzo flooring are cured?
- 4) To which Building Granolithic floor are provided?
- 5) What should be the thickness of Ellispattern floor in centimetre.
- 6) What should be the form of stone slab floor.

### **PART-C**

#### **III. Answer in one (or) two sentences**

- 1) Write 4 types of floors.
- 2) Write the materials used for flooring.
- 3) Write two qualities of a good floor.
- 4) What are the types of composite floor?
- 5) What is the difference between Granolithic floor and Terrazzo floor?
- 6) What are the materials used for external plastering?
- 7) What are the types of floor spread.

## **PART-D**

### **IV. Answer in Shortly**

- 1) Draw the neat sketch of Timber floor and define.
- 2) Draw the sketch of cement concrete floor and explain.
- 3) Define the construction of Mosaic on the concrete base.
- 4) Define R.C.C. floor.
- 5) What are the requirement of Good floor.

## **PART-E**

### **V. Answer in Detail**

- 1) Define the various types of floor spread and floor finishing?
- 2) Write the types of floor and define any three with sketch.

## UNIT-VIII

### 8.1 AUTOCAD

#### 8.1.1 INTRODUCTION

The Shortest form of computer Aided design is CAD. Before constructing a building the preparation of drawing such as elevation, plan are drawn and the building is constructed as per the drawing. So by using computer we can draw the plan with utmost care and clarity at the same time we can draw fastly according to our taste.

#### AUTOCAD

An American company called Auto Desk prepared Auto Cad. This software is highly used for the preparation of drawings, particularly in other branches like Civil, Mechanical, Electrical, Electronics.

#### Usage of Auto Cad for drawing with computer

- 1) If drawing is prepared by using Auto cad a beautiful, clarity, good type of drawing can be obtained instead of manual preparation of drawing.
- 2) It will take much time while using varieties of colour lines in manual drawing. But within a short time all these can be done in Auto Cad.
- 3) It is very tough to edit (or) correct manual drawing. But corrections can be easily done in Auto Cad.
- 4) We can show the original appearance of the building by drawing the three dimensional sketches in Auto Cad.
- 5) We can show through a drawing the needed requirements in a house by getting information from the owner of the building. It is not possible in manual drawing.
- 6) As per our requirement we can make some changes in the drawing and several copies may be taken at a time. It is not possible in manual drawing.
- 7) By joining the two drawings and we can make it as a single drawing. It cannot be done like that in manual drawing.

These are all the usages of Auto Cad while using it in a building drawing.

#### Auto Cad commands

To draw a sketch in a computer (or) Auto Cad so many commands are used for drawing. For this there was a necessity of compulsory typing of release 14 in a command box. But in the latest (or) modified software of Auto Cad 2000, 2002, 2004, 2007, 2010 the highly used commands are given in tool bar (or) icon. Let us know the required commands to draw a building drawing.



## **Units**

- 1) Selecting the limits of unit is to be done before drawing a sketch. (Eg) Decimal, Engineering, Architectural, Fractional and Scientific.
- 2) Selection of Drawing unit format. (Eg) Millimeter, Centimeter, Feet, inches etc.,
- 3) Drawing the angle of measurement in a sketch. (Eg) Degree / min / Sec gradients, radians etc.,
- 4) These commands are used to control the direction.

### **8.1.3. FUNCTION KEYS**

Esc Whatever may be the commands used. 'Esc' key is used to come out from the command.

F1 Key helps to know the Auto Cad perfectly. This is an help window for Auto Cad function key.

F2 is an Auto Cad text window. The function key are used to open the file and thus it is used to know the command we have used.

F3 is an OSNAP function when a command is under progress symbols of mid point centre point perpendicular etc., of a drawing can be shown by using this OSNAP function.

F7 Snap on (or) snap off to control the cursor moment in a drawing snap is used. Isometric views can be drawn by using this key.

F8 Ortho on (or) Ortho off

#### **Ortho on**

In this position  $0^\circ$  to  $90^\circ$  lines are drawn from one point to other point.

#### **Ortho Off**

In this position we can draw the line according to our required angle from one point to another point.

#### **F9 Grid on (or) Grid off**

When grid is on the points of 'X' axis and 'Y' axis like graph sheet are seen in window of Auto Cad drawing. But it is not visible in print out. Grid on position are used to draw straight line. Also we can know how far we are selecting the limits of drawing.

F10 Polar on (or) Polar off

#### **Polar on**

In polar on position when lines are drawn from a point to another point by using line command the distance of line, angle of line can be known. It can be used to draw the line to our required angle.

## **File management**

New : This command is used to draw a new drawing on Auto Cad.

Open : It is used to open the saved drawing which is already drawn.

- Save : It is used to save the drawing we have already drawn in Auto Cad Window.
- Save As : It is used to take the print out of duplicate copy (or) to change the title of drawing which is already. Saved and to save it in another file.
- Quit : This command is used to come out from AUTO CAD.
- Plot : This command is used to print the drawing of auto cad.
- Export : This is used to change the drawing file drawn from Auto Cad to another file.
- Exit : It is used to come out from auto cad to desk top.

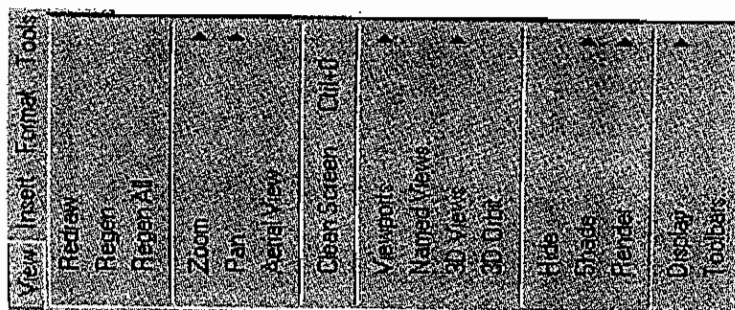
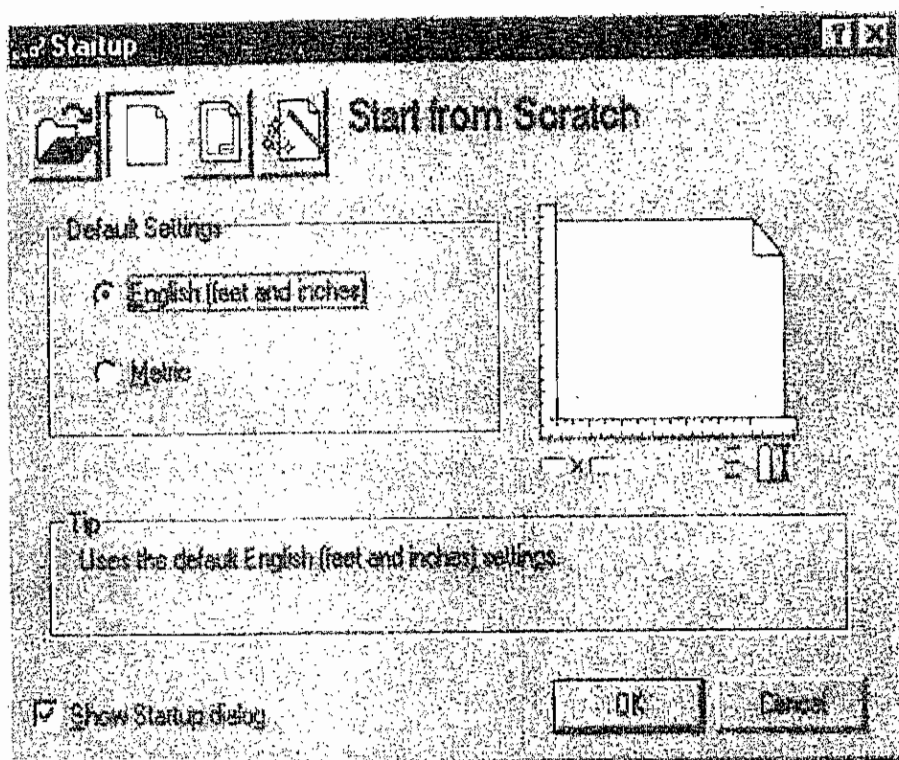

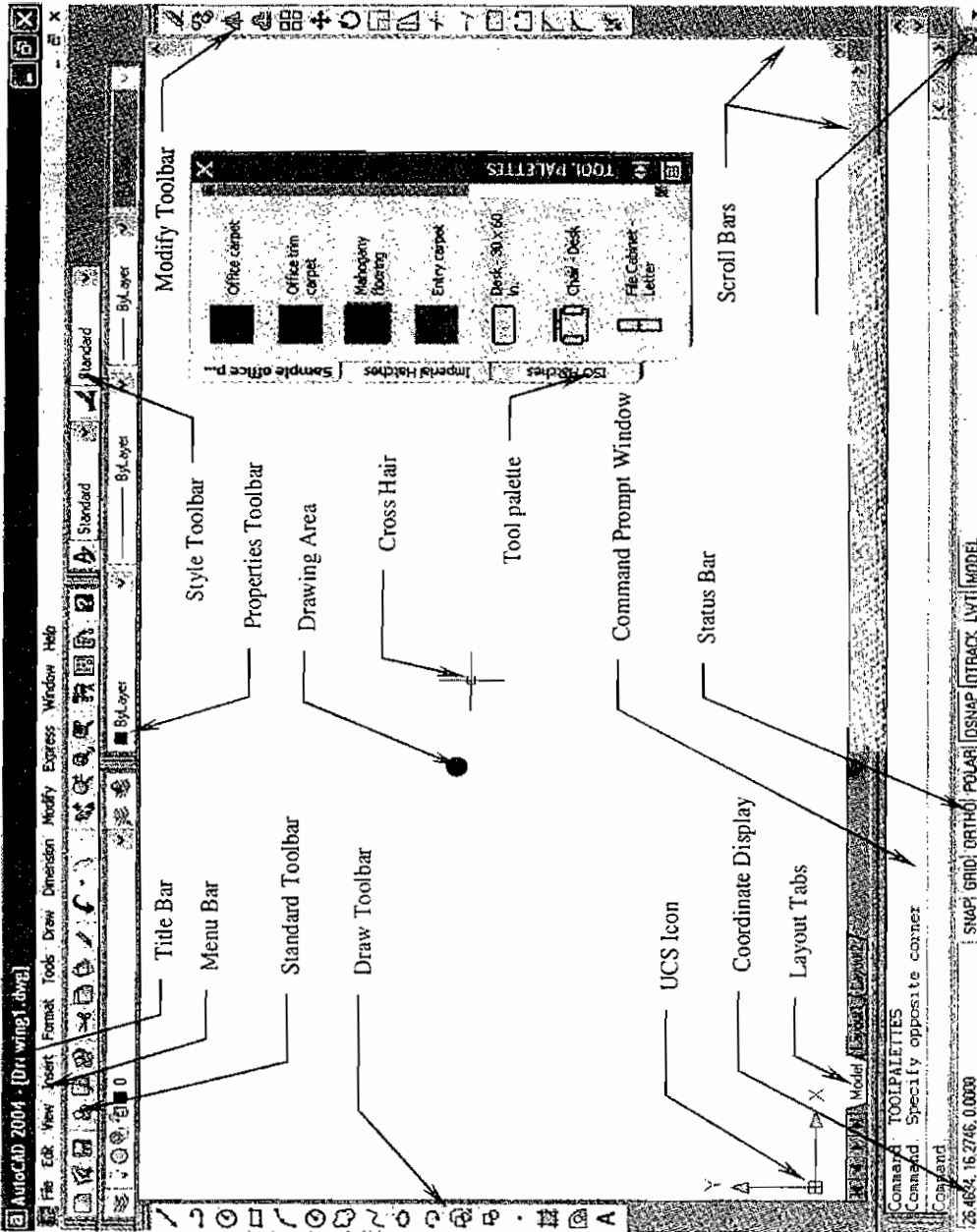





### 8.1.5 DRAWING LIMITS

Before we draw a sketch we have to know the limits of the drawing we have to draw the boundaries of the size of drawing like the selection of size of drawing sheet (A1 A2 A3 A4) in manual drawing. In XY direction this measurements should be given.

### 8.1.6. DRAW COMMANDS

#### a) Line

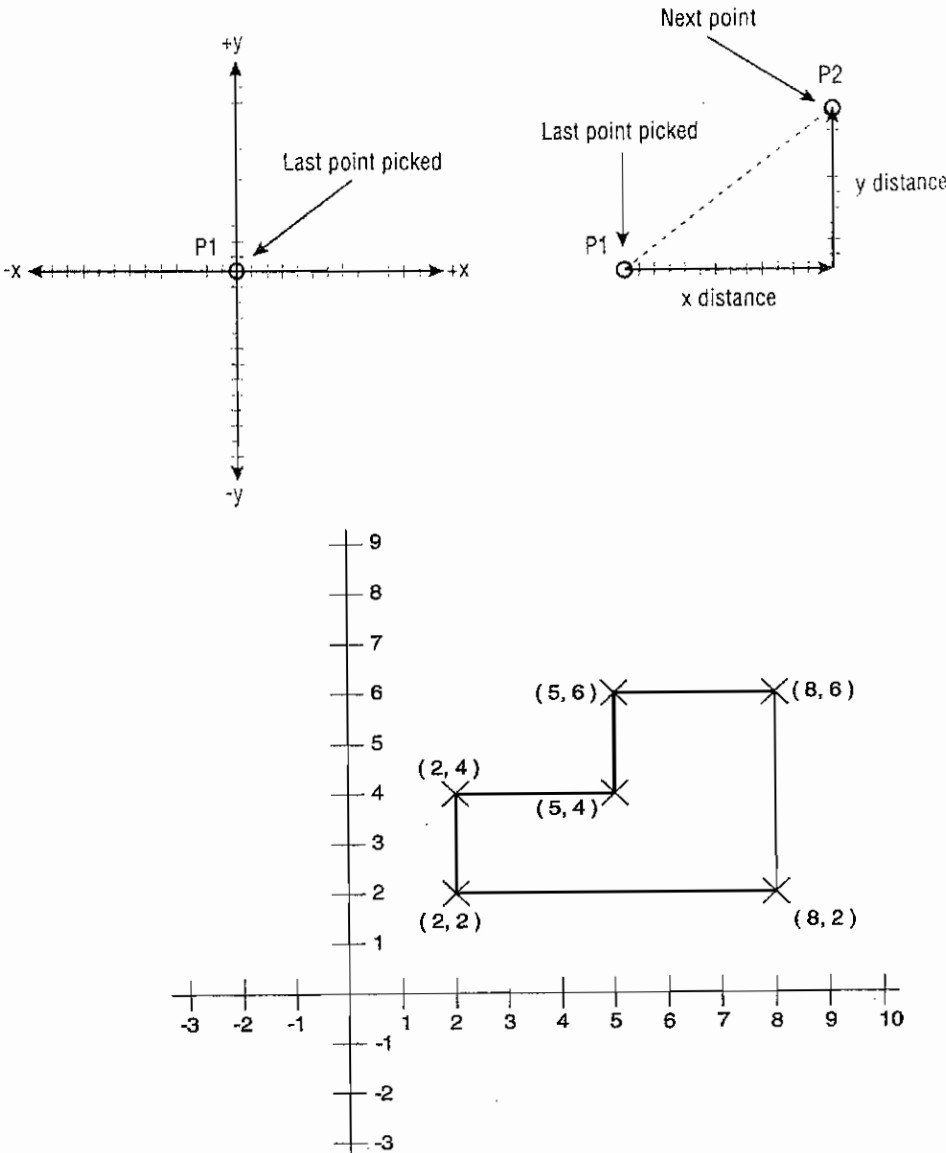

We can draw a line by using the line command. By commands we can type the size.

**a. 1. Absolute co-ordinate method**

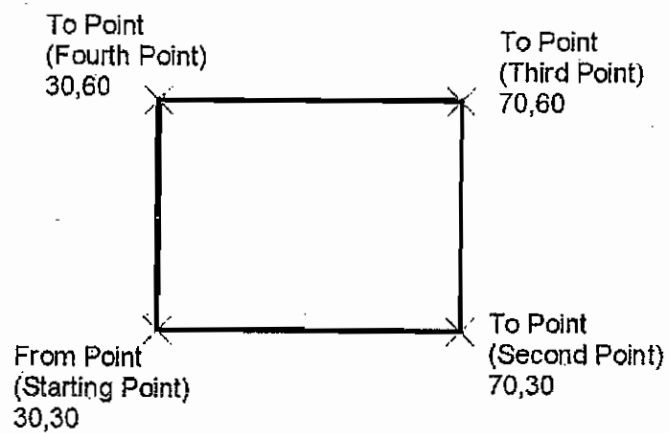
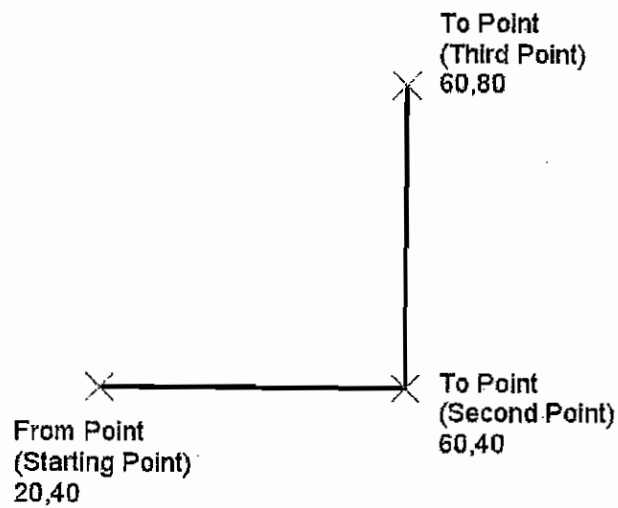
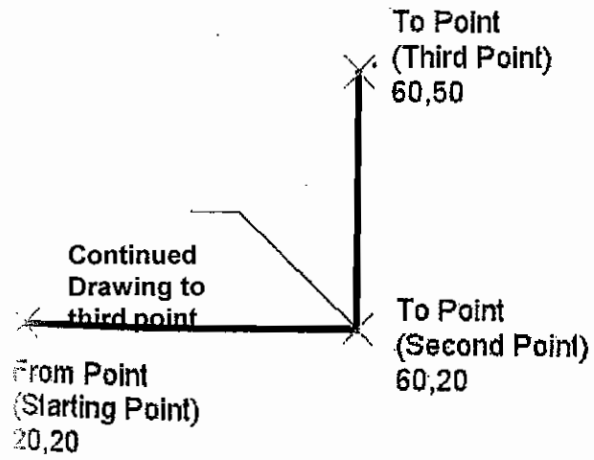

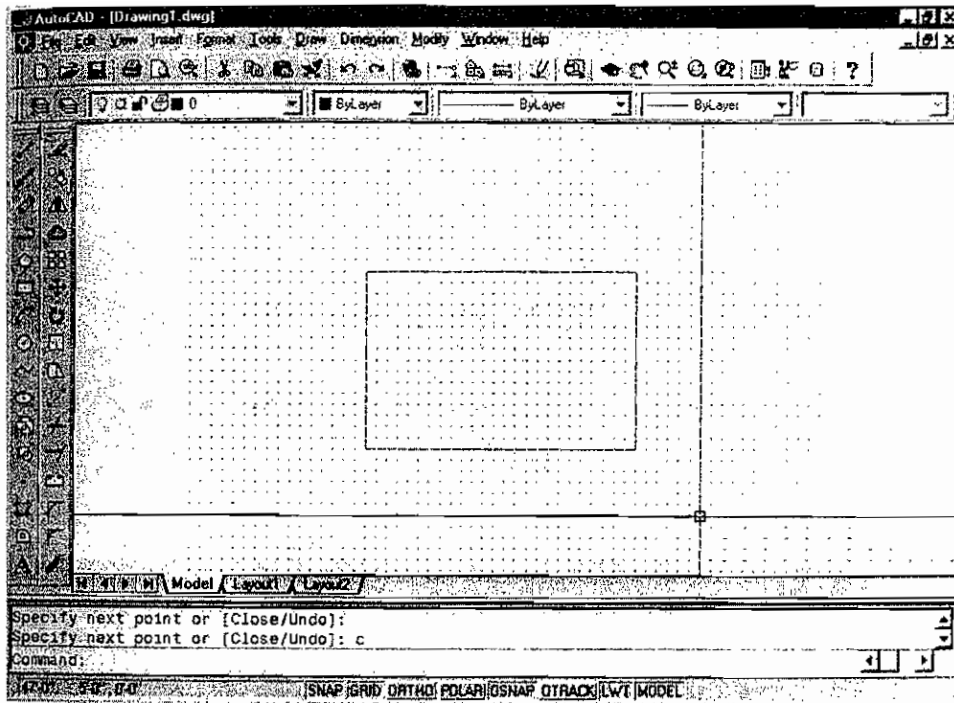

In this method we have to give the statement of points from origin.

## 2. Relative co-ordinate method

In this method we have to give the co-ordinates of the starting point towards X-axis (or) distance of y-axis from the point.

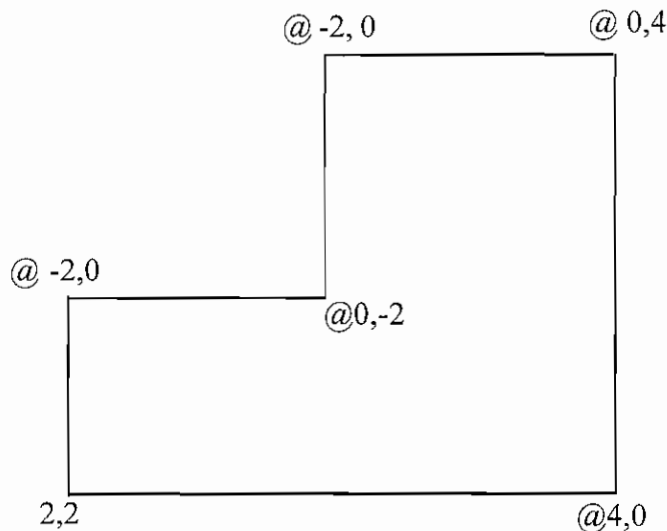

## 3. Polar co-ordinate method

In this method sketch is drawn by giving the angle of direction and distance from starting point to next point.



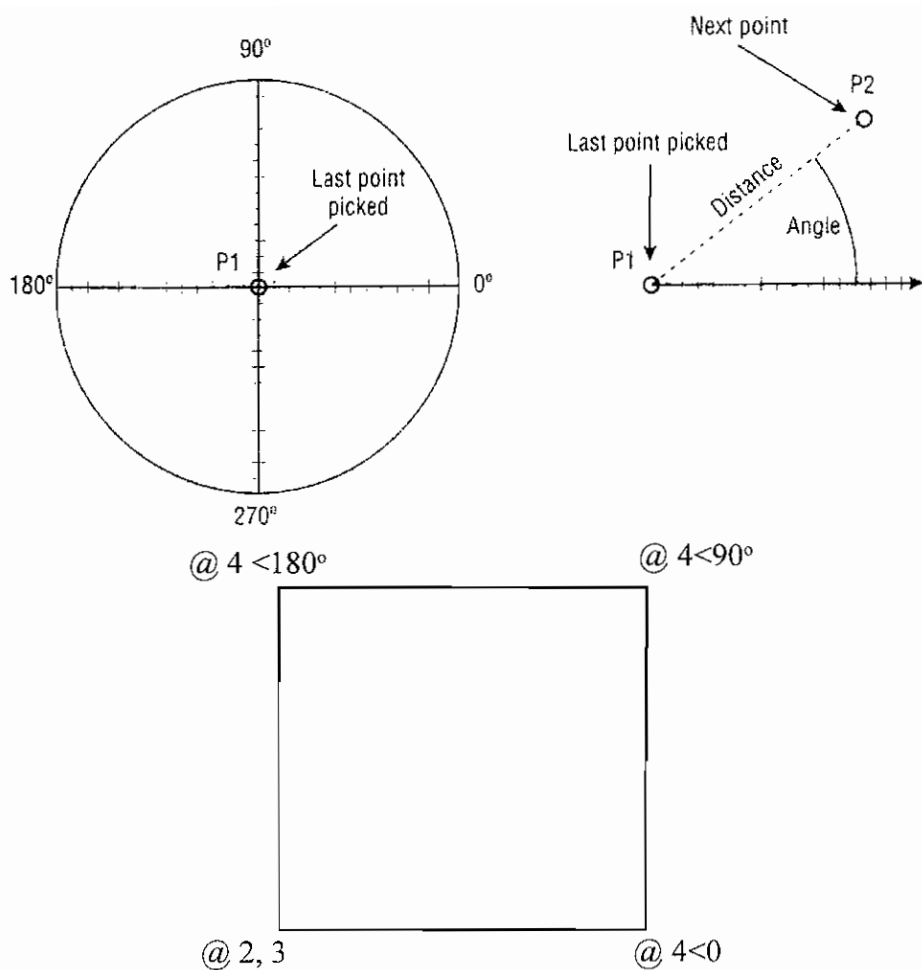

## b. Poly line

Poly line means many characteristics of a line.

### Special characteristics of a poly line

Line that is drawn with the help of poly line has a single characteristic features.

- 1) We can enlarge the size of thickness of a line.
- 2) With Poly line we can draw different shaped drawings with a single characteristic feature.
- 3) The line drawn by poly line can be easily changed. To do this command PEd is available.
- 4) One line can be joined with another line with a single characteristics poly line.
- 5) Structure of several lines drawn with a poly line is called as an object. This command is highly useful for drawing area, circumference, hatching.

### c. Circle

Generally to draw a circle if there is a centre and radius we can draw a circle and we can follow this methods to draw a circle.

#### a) Centre point radius method

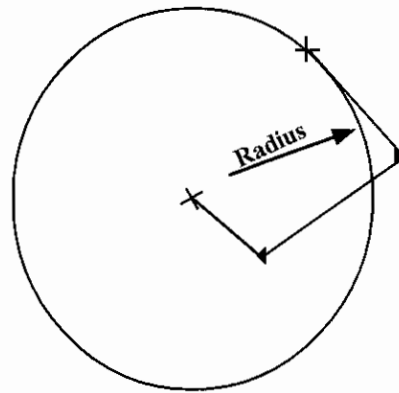

#### b) Centre point dia method

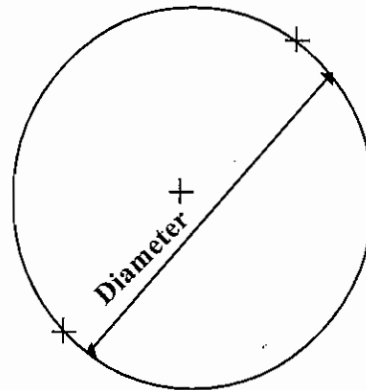

#### c) Three point method

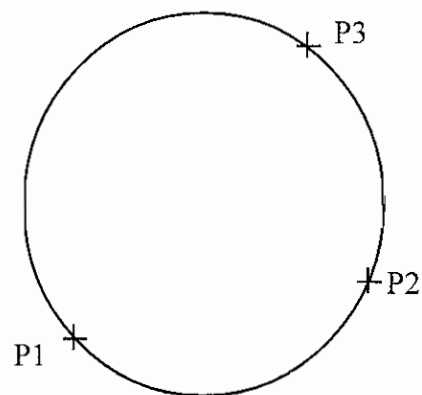

d) Two point method

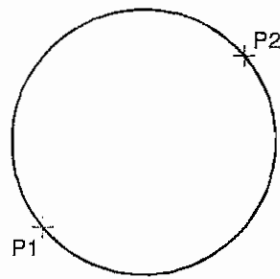

e) Tangent radius method

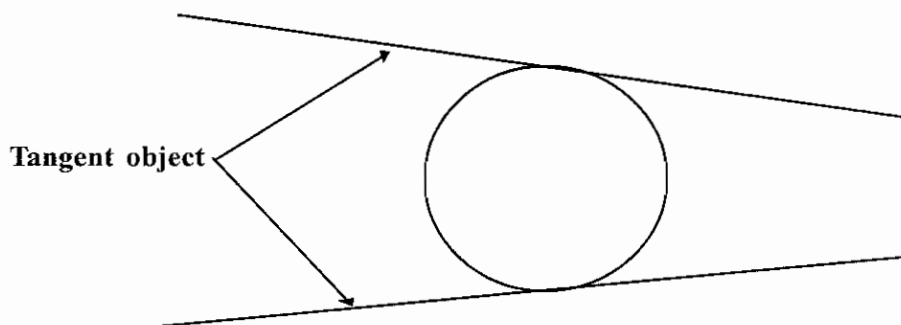

d) Rectangle

There are two dimensional measurements available for rectangle such as length breadth (or) depth. We are not using the measurements when we are drawing by Auto Cad. Instead of that rectangle is drawn with two diagonal.

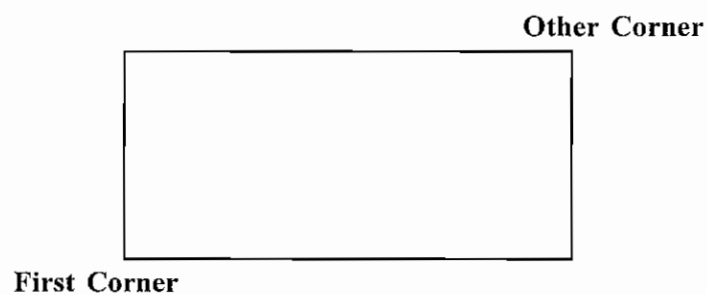

We have to give the values of lower edge of right side and values of opposite corner of the rectangle. Two corners are noted as first corner and other corner respectively. The inner commands such as syntax / chamber / elevation / fillet / thickness / width / are in this method.

### e. ARC

Curve (or) Semi circle is called as Arc. Three points are required to draw a arc. Also we can draw the arc with the centre point of arc, Angle of arc, radius of arc. There are six methods to draw a arc.

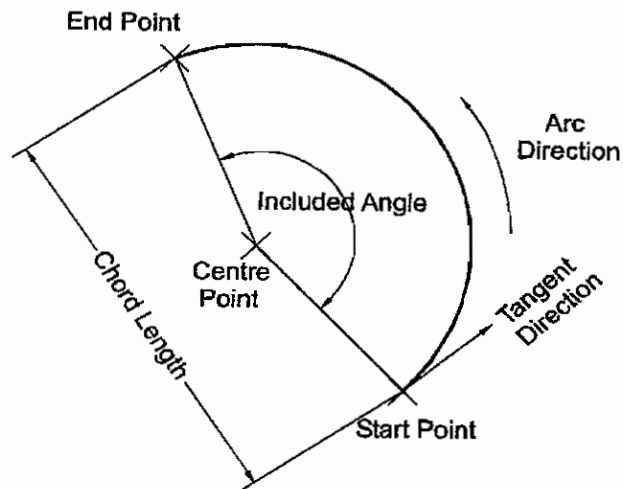

a) By three points

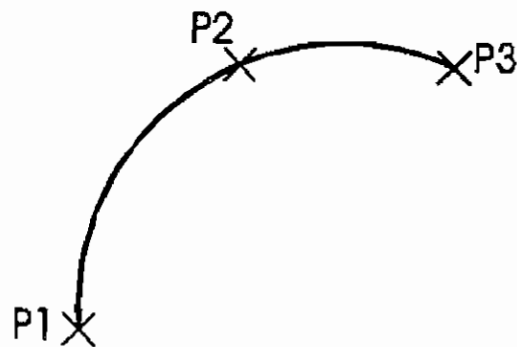

b) By start, centre, end point.

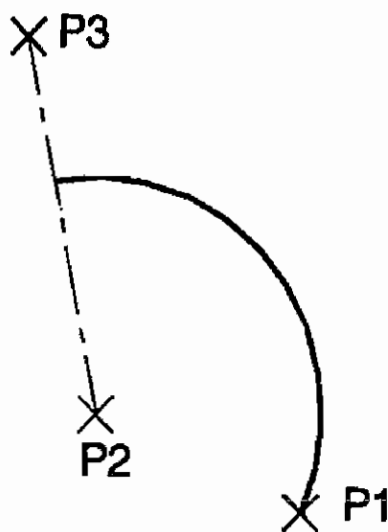

c) By start, centre, included angle.

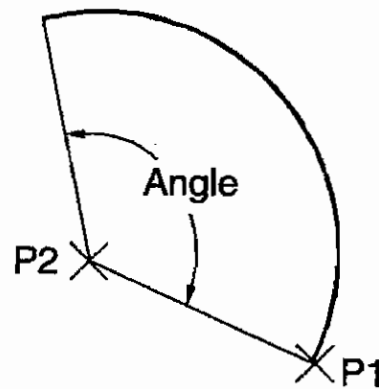

d) By start, centre, length of the chord.

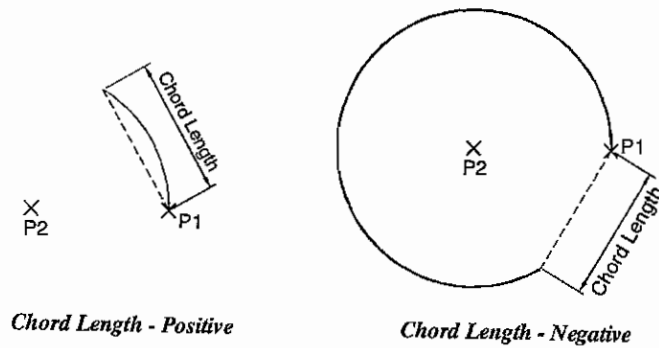

e) By start, end, radius

f) By start, end, direction.

### f) Polygon

A drawing drawn with several angles (or) with several sides is called polygon. In this angle (or) sides should be in equal measurement. Polygons of 3 to 1024 sides can be drawn.

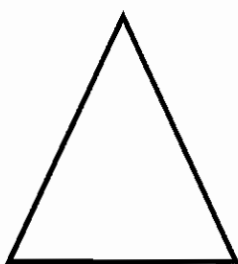

3 side

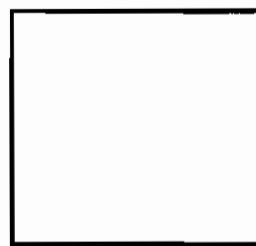

4 side

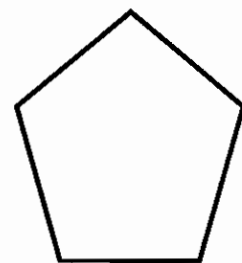

5 side

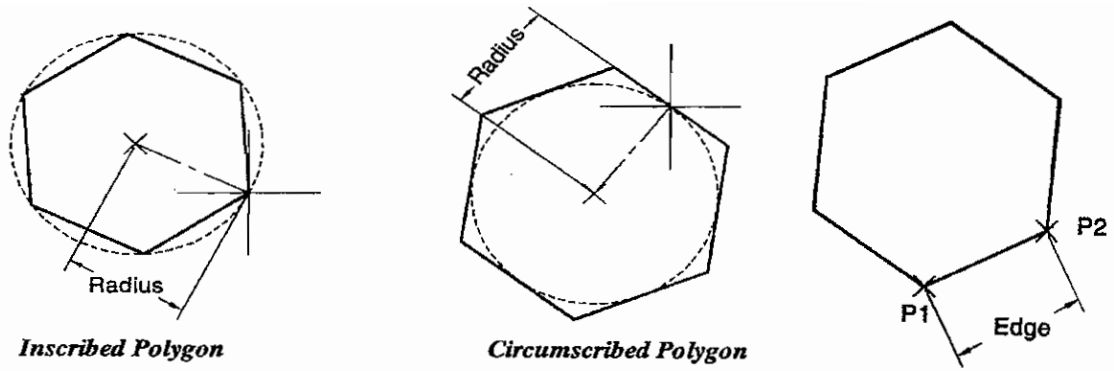

**Inscribed Polygon**

**Circumscribed Polygon**

**g) Ellipse**

Ellipse is a circle drawn by two different axis. One axis is noted as major and another is noted as minor. It is noted that half of the distance of minor axis is axis distance. With this point we can draw the ellipse in 4 methods.

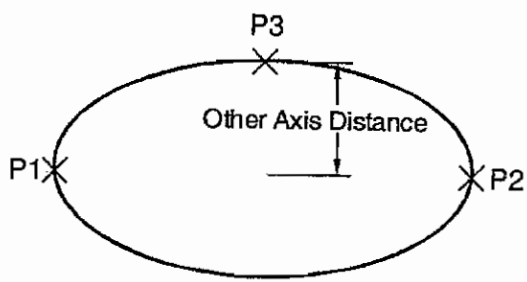

**Ellipse by axis endpoints**

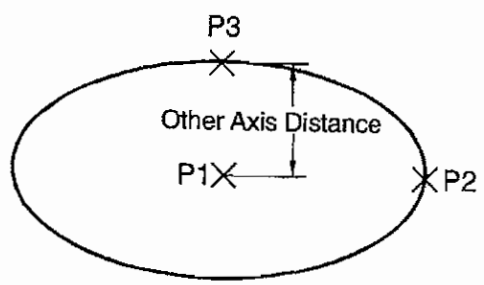

**Ellipse by axis Centre point**

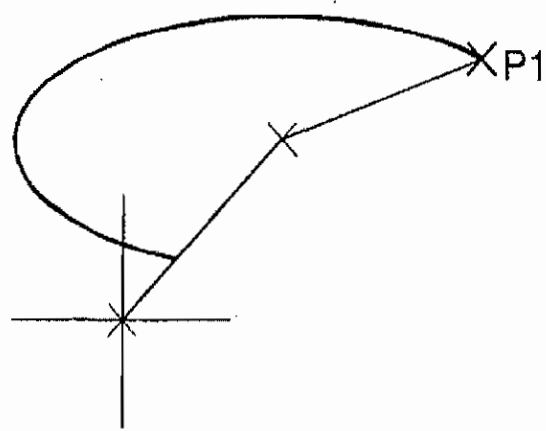

**Ellipse arc by start and end angles**

## QUESTIONS

### Part A

#### I. Choose the best answer

- 1) The country developed the software of Auto cad.  
a) Indian                      b) Japan                      c) China                      d) America
- 2) The concern developed the software of Auto Cad.  
a) Auto desk                      b) Auto Car                      c) Auto Cad                      d) Tally
- 3) To draw the drawings which branch uses the computer  
a) Civil                      b) Mechanical                      c) Electrical                      d) All the above.
- 4) Very tough to make correction (or) to change the drawing.  
a) Drawing by computer                      b) Manual drawing  
c) Computer and Manual drawing                      d) none of the above.
- 5) The command used to draw new drawing.  
a) save                      b) open                      c) New                      d) plot
- 6) The name of command used to take print out from Auto Cad  
a) Quit                      b) Plot                      c) Exit                      d) Save as
- 7) In how many way the drawings are drawn by using the command 'line'.  
a) Eight                      b) four                      c) three                      d) two
- 8) The command having two different axis.  
a) Circle                      b) curve                      c) Ellipse                      d) Polygon
- 9) Which point is necessary to draw a circle.  
a) Starting point                      b) Centre point                      c) end point                      d) Radius.
- 10) What lines can be drawn with the given angle using Ortho on stage.  
a)  $0^\circ$  to  $90^\circ$                       b)  $90^\circ$  to  $45^\circ$                       c)  $30^\circ$  to  $45^\circ$                       d)  $30^\circ$  to  $60^\circ$

### Part B

#### II. Answer in one (or) two words

- 1) What is the expansion of CAD
- 2) Who developed AUTO CAD
- 3) What is the name of software used to draw the drawing in computer.
- 4) What are the axis initially used to draw lines.
- 5) In how many methods circle can be drawn by using circle command.

- 6) With how many minimum sides polygon can be drawn in a computer.
- 7) With how many maximum sides polygon can be drawn in a computer.

#### **Part C**

#### **III. Answer in one (or) two sentences**

- 1) What do you mean by the software AUTO CAD.
- 2) Mention 4 commands used for drawing.
- 3) Define circle command.
- 4) Define line command.
- 5) Define curve command.

#### **Part D**

#### **IV. Answer shortly**

- 1) Define AUTO CAD.
- 2) Define any 4 commands used to draw
- 3) Define methods of drawing the circle with sketch.

#### **Part E**

#### **V. Answer in detail**

- 1) What are the uses of AUTO CAD by using computer.
- 2) Define any 4 commands.



## 8.2 AUTO CAD CONTINUATION

### 8.2.1. MODIFY COMMANDS

#### a) Erase

By using this command objects of one (or) several lines are removed (or) erased.

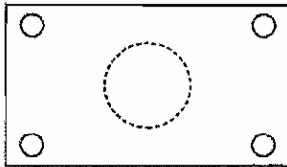

*Object Selected*

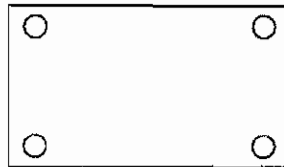

*After Erase*

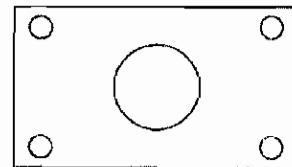

*After Oops*

#### b) Copy

Initially the object is drawn while duplicating the object. Then the base point is selected and the duplicate object is fixed at the displacement point.

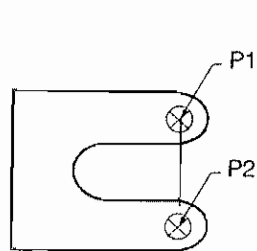

*Single Copy*

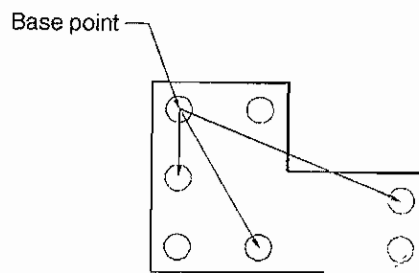

*Multiple Copy*

#### c) Mirror

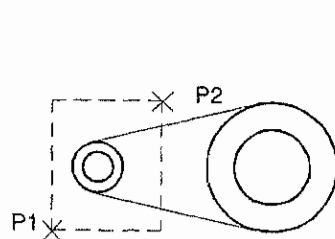

*Object Selected*

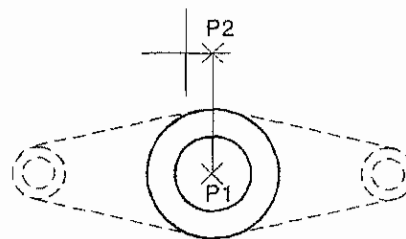

*Mirror Line*

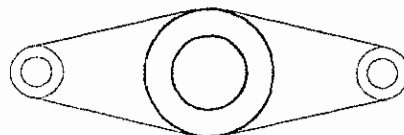

*Original Objects Retained*



*Original Objects Deleted*

If an object is placed in front of a mirror the objects reflects in the mirror. Like this if we draw mirror line at an object then the object will reflect in reverse direction.

We can fastly draw the symmetrical figures by using this mirror command. Hence it reduces the drawing time.

#### d) Offset

By using this command curves, circles, rectangles are drawn parallel to some distance

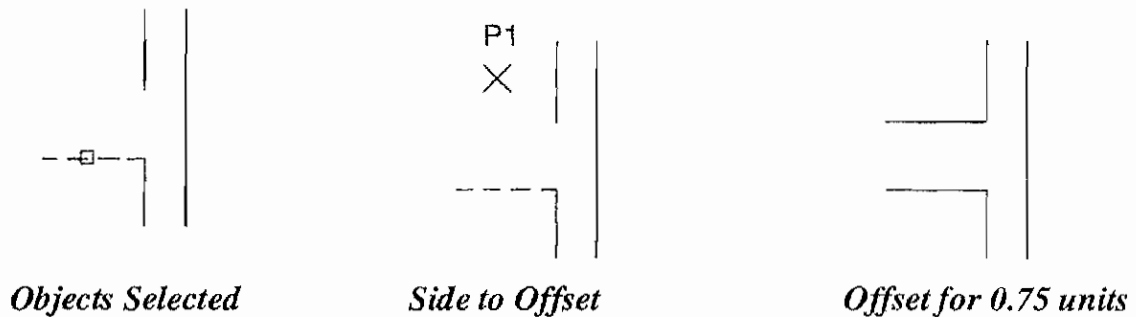

#### e) Move

When an object is moved from one place to another place it is called moving. It is similar to copy command as we seen earlier.

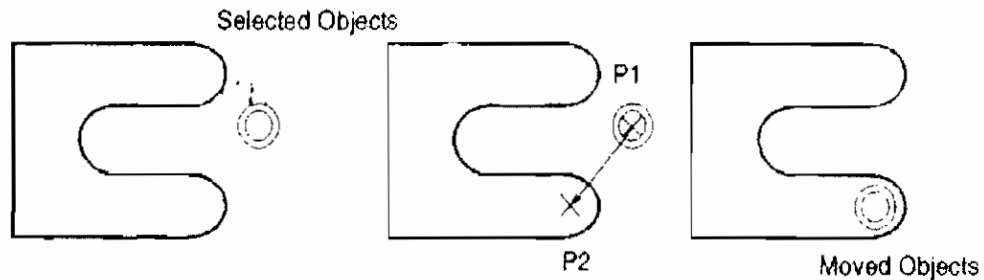

But the only difference is old object and duplicate object will be in copy command. But after moving the object in move command the old object will not be there.

#### f) Rotate

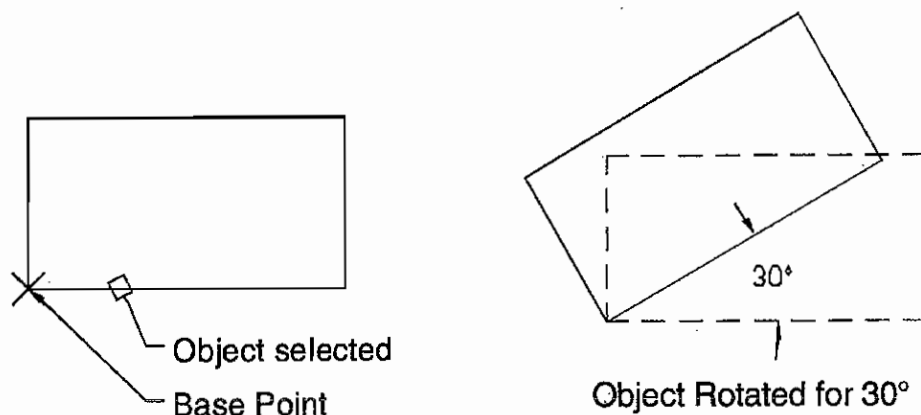

We have to use rotate command to rotate all the drawn objects (or) drawing object. That object may be changed from one point to another angle.

### g) Hatching

This command is used to construct a sectional view of the drawing object and to show the inner parts of the objects in detail, within the boundary of the drawing differentiating several parts by filling several patterns.

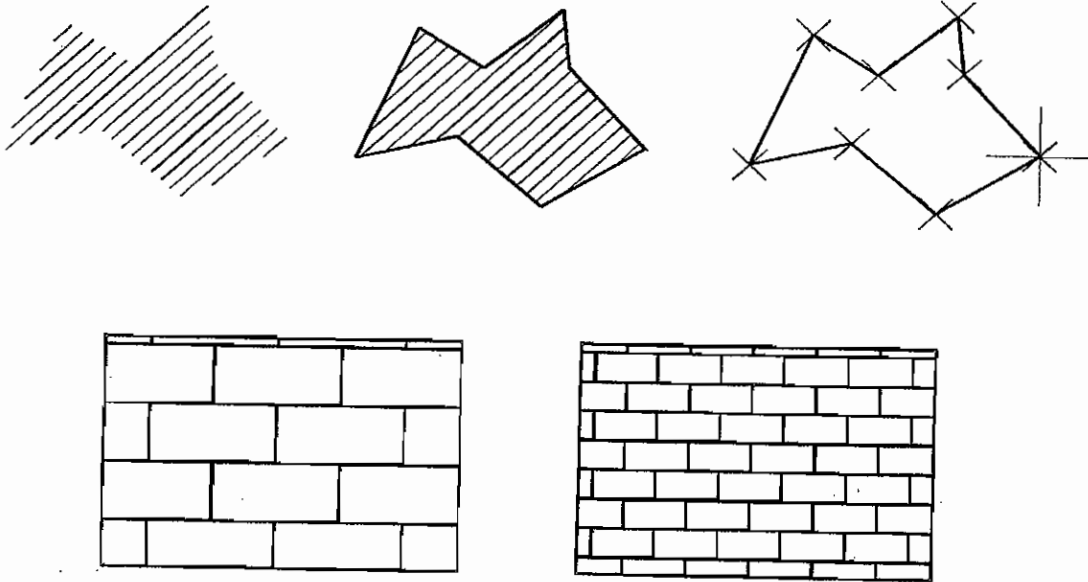

Particular boundary should be a closed boundary of line, curve, circle and polyline.

Also Hatch pattern can be edited. If we have to edit the hatch pattern before that the pattern should be exploded. Then lines in the pattern can be erased (or) alternative lines may be drawn.

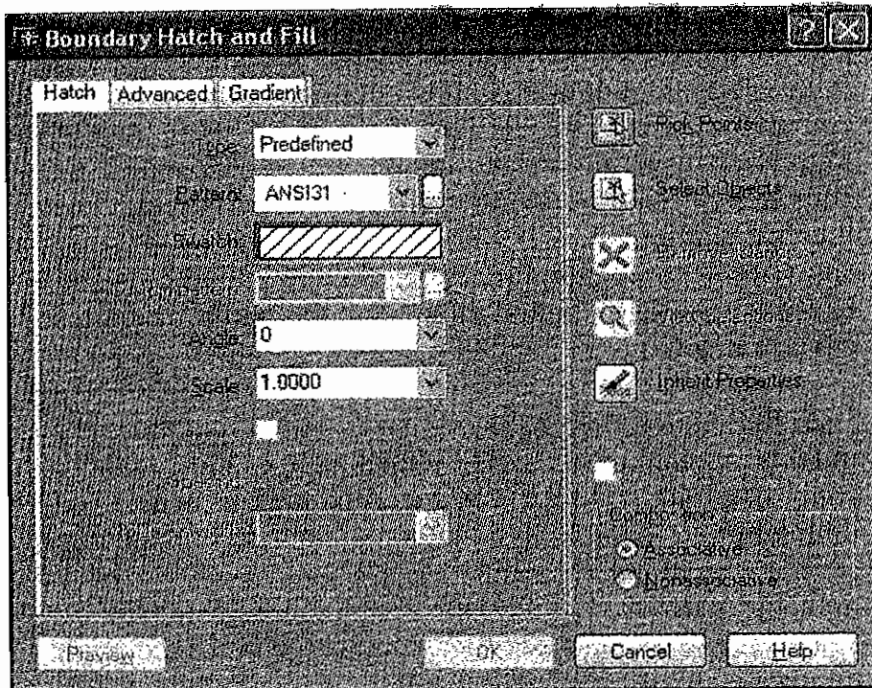

## h) Array

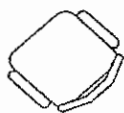
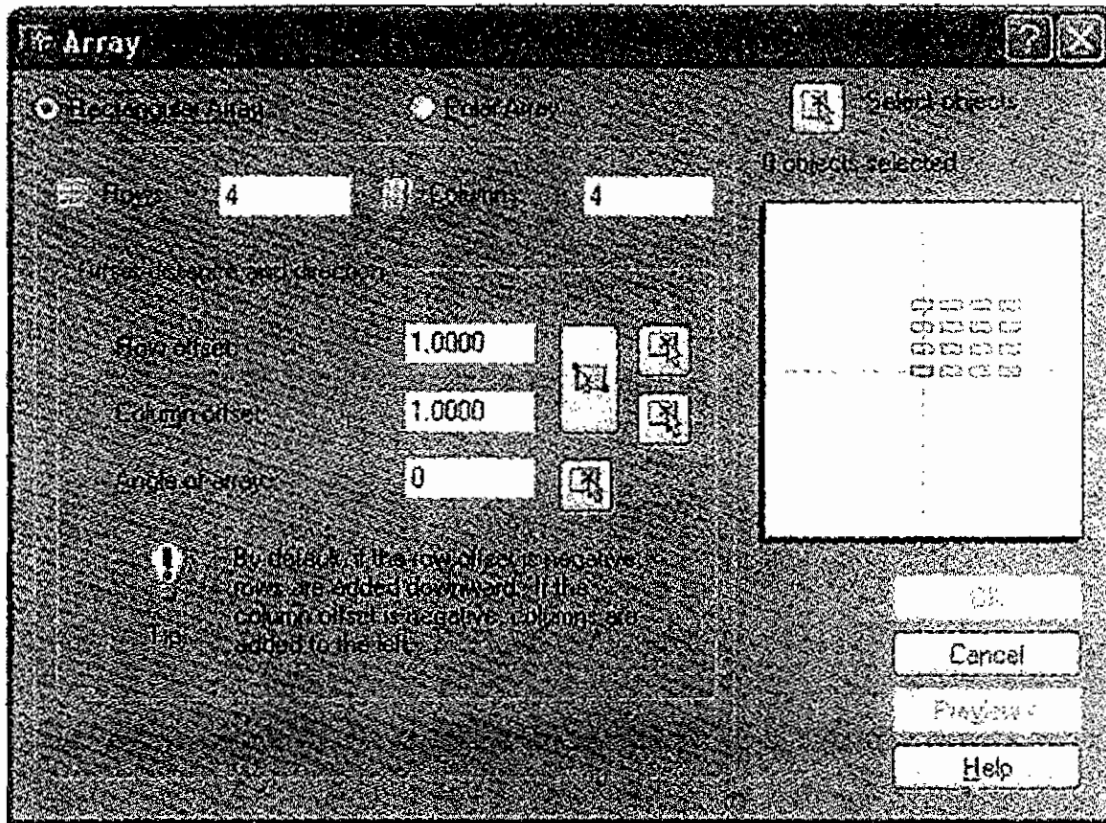

*Before Array*

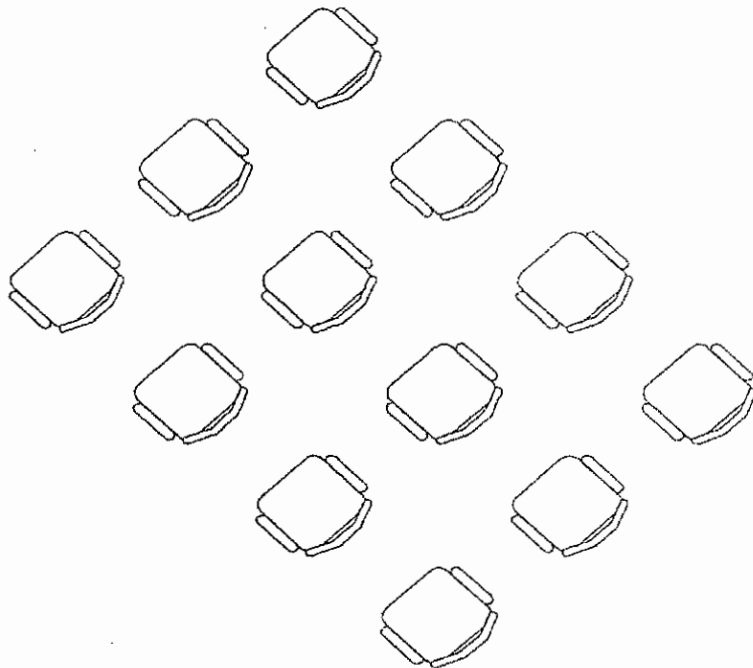

*After Array (Angle of Array = 45)*

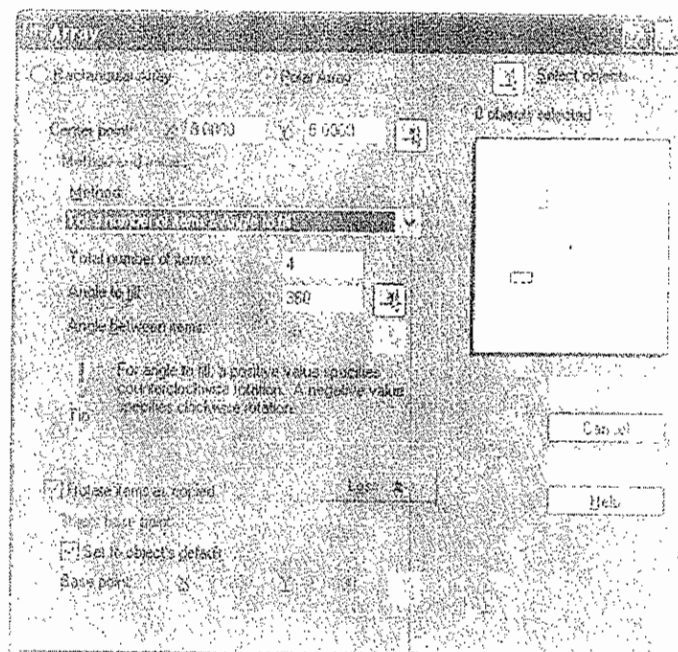

Classifying an object in uniform order is called Array command. This may be formed by a square (or) Rectangular, circular classification. Array of square formation is called Rectangular Array. In this order they are classified into two parts such as rows and columns. Horizontal formation is called row and vertical formation is called columns.

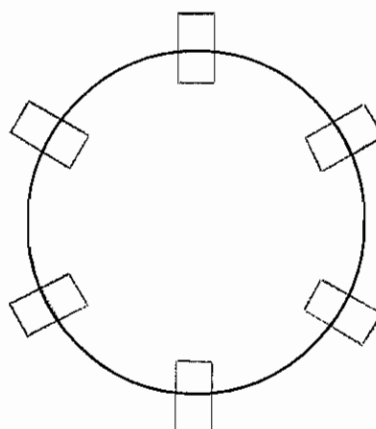

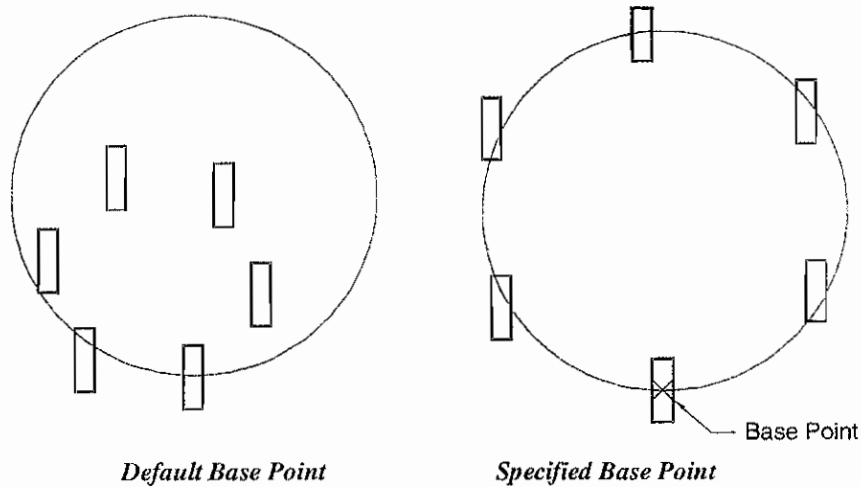

Circular Array is called circular class (or) Polar Array. We can classify the objects to our required form such as full circle (or) semi-circle.

### i) Stretch

This command is used to extend (or) reduce an object. This is like lengthen command. But we can only reduce (or) extend the line in lengthen command.

But any form of an object can be extended (or) reduced in stretcher command. In another sense size of the object such as length, breadth, height can be altered.

To select the object in this command we have to use cross window option and selection of extension portion is done. In order to make the other end of the object steady we can stretch the objects of curve, polyline, solid by using this command.

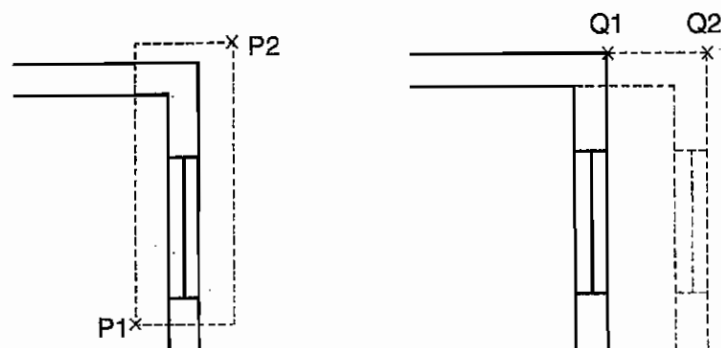

### j) Trim

After drawing an object the unnecessary lines are removed from the particular place by using this command. We have to select the edge when this command is used at the edges. If more than one cutting edge is there all the cutting edges should be selected. Then we have to select the unnecessary lines in order.

We can trim the form of circle, curve, polyline by using this command.

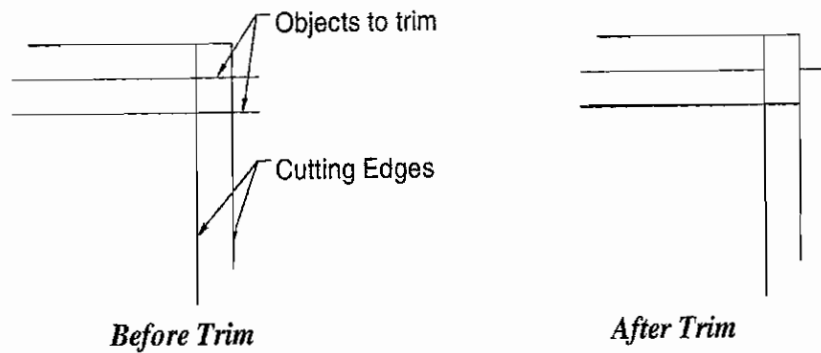

### k) Extend

This command is used to extend a line like lengthen command. We can use this command to extend the line and curved object. It will ask location of boundary edges while text ending a line in this command. If we select the boundary edge, that line will be extended. The line is extended up to the selected boundary even though if there is any object in the centre. In this boundary object line, polyline, circle, ellipse and letter are used.

### l) Break

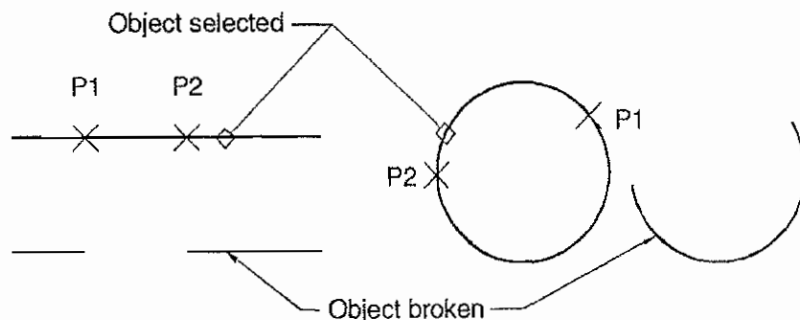

This break command is used to estimate the middle portion of the line (or) edge. By using this command we can break a line, circle, ellipse, polyline.

### m) Block

We can save a drawn object (or) full drawing by using block command. We can save an object by giving a block name while using this block command.

### n) Insert

Assuming that we have blocked the drawn points required for the drawing that can be used in various places, various sizes and in various angles in the drawing.

### o) Distance

To know the distance from a particular point to another point this distance command is used. Also we can know the intermediate distance of line. We have drawn (or) distance between two objects may be known.

### 8.2.2 Text command

Change  
P1

P1 X AutoCAD X P2  
Sample  
Text Line Entry

By using this command letters and numerals are typed by using the key board and if enter key is pressed all the typed matter in the monitor screen will come out. But in this command the typed matter is not visible. So we are not able to give proper location. So this command is not so useful. To avoid this problem D text command is available. Dynamic text is called D text.

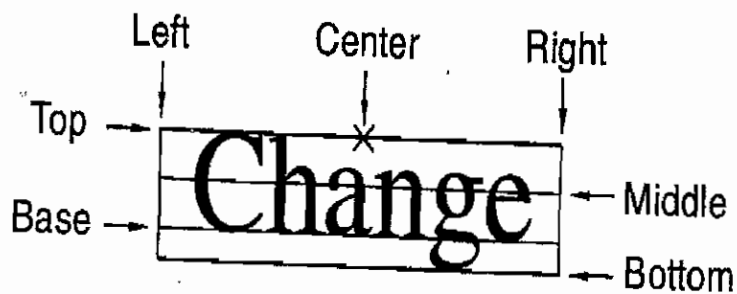

#### Vertical Justification

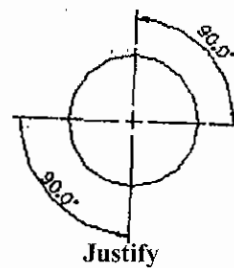
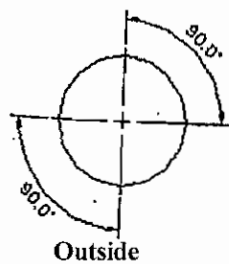
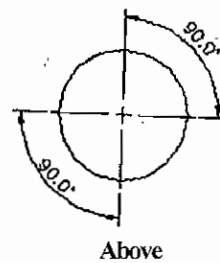
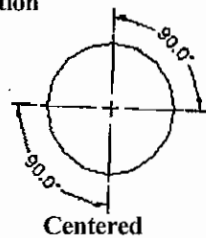



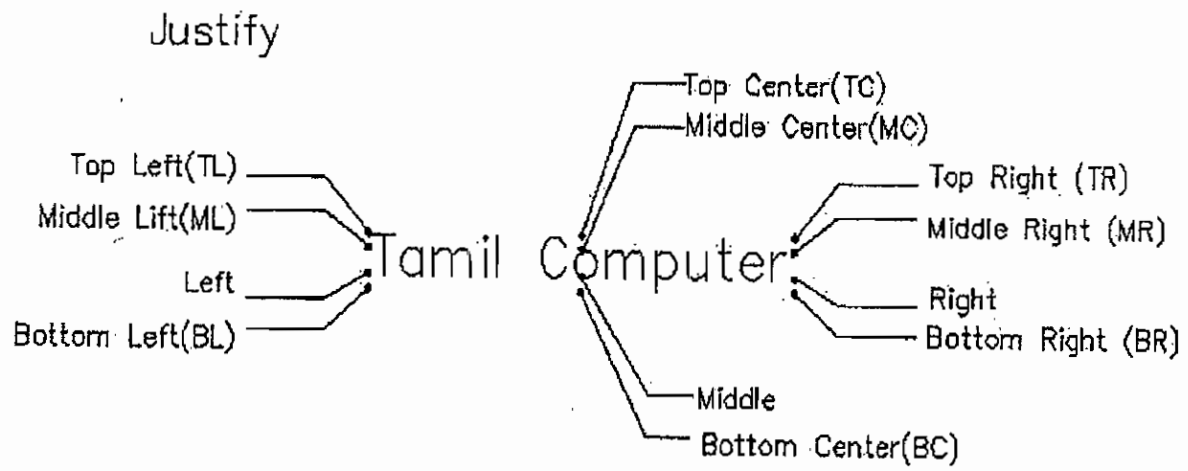

Left (Default Setting)

### Editing Text

Assuming words (or) parts are typed in several places in drawing. If there is any spelling mistake in the typing it may be corrected by using this command. When letters are typed it becomes an object. So spelling mistake is made correct by using this command.

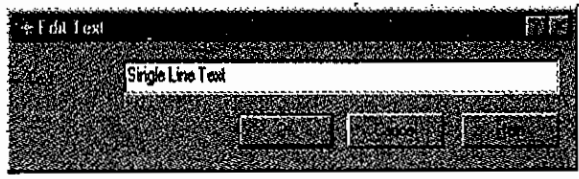

### M Text

Command M text is used to form the typed words into a sentence. This command will decide the text boundary. The typed sentences are included in the boundary. The above lines are formed as single object.

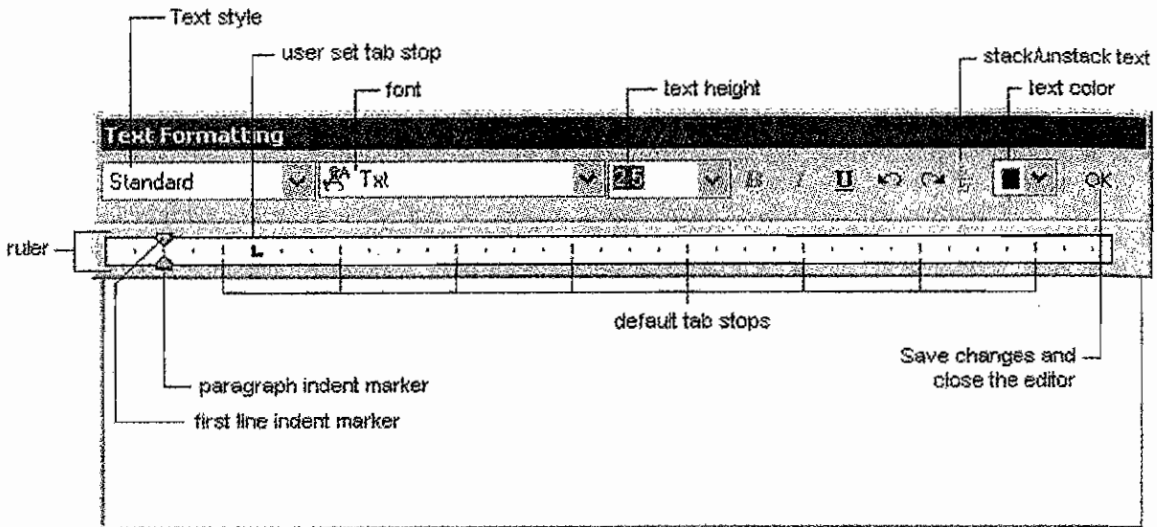

## ZOOM

This command zoom is used to see the object by magnifying (or) reducing it.

Extend (or) E

It helps to show the whole drawing even if the drawn sketch is out of the limit.

Zoom extent

Zoom window

Zoom Dynamic

Zoon Centre

ZoolAll

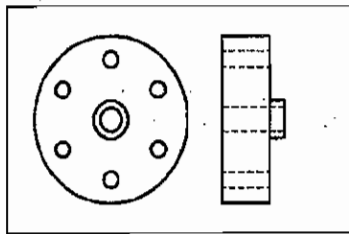

*Current View*

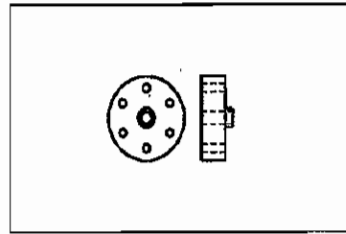

*After Zoom - Scale 0.5*

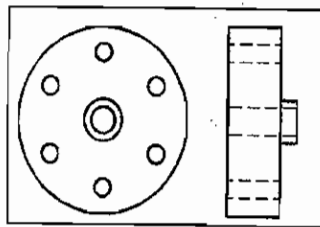

*Before Zoom - All*

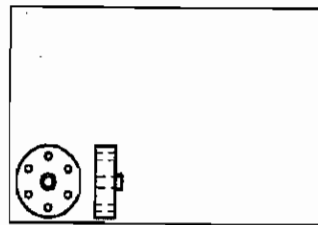

*After Zoom - All*

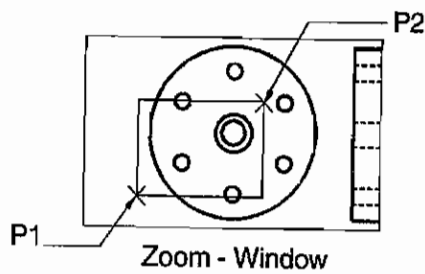

*Zoom - Window*

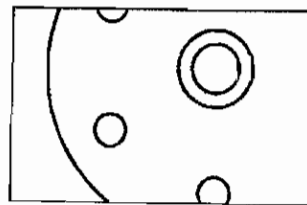

*Zoom - Window (Before and After)*

### 8.2.3 Dimension

If we have drawn an object and if there is no measurement then the drawing will not attain its fulfillment. If we furnish the details such as length, breadth, depth, angle, radius, diameter of the object then the object gets the nature of producing formation. Dimension method is available for drawing this measurement. Some commands are available for this method.

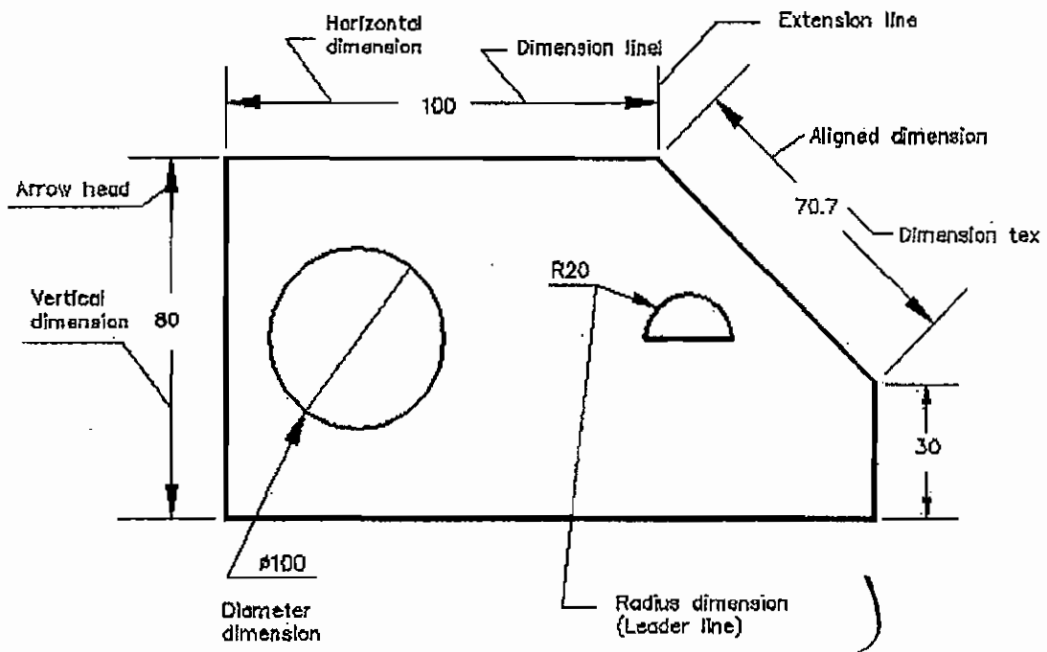

### Methods of measurement

In the classification of dimensioning there are linear, angular, radius diameter and co-ordinates are available. Now we can see some dimension variable used in dimension part.

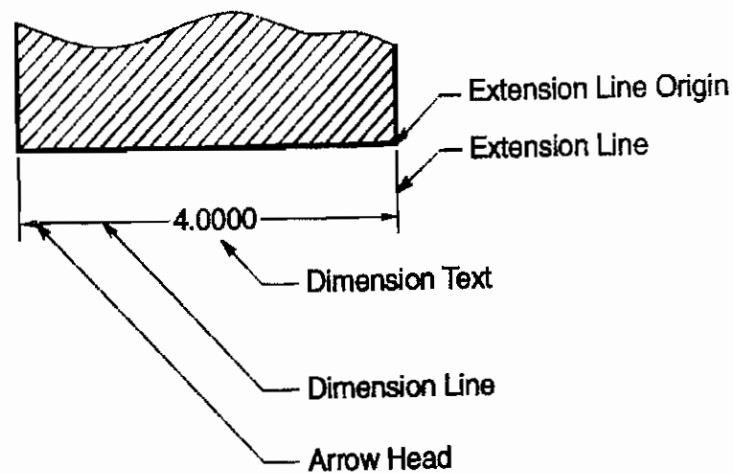

## Dimension line

Dimension line is a single line. Side measurements of the object are indicated with Arrow mark from one end to another end.

A single line indicating the side measurement of object from one end to another end with arrow mark on both side are called dimension line. The vertical line from both side of the object is called extension line. In the middle of dimension line, the size of measurement for that side is indicated. We can fit the dimension line according to the convenience. Also we can hide the dimension line according to our convenience. For that the option suppress is available. In this there is a way to hide the first line (or) second line (or) both line.

## DIMENSION TEXT

Selection of actual size of the side of an object by AUTOCAD is called dimension text.

That is drawing a size of line 100 and by giving dimension command two edges of dimension line are selected in such a way it selects dimension text 100. If there is any necessity to change the value of this text there is an alternative option called new text is also available. By noting prefixes and suffixes to this text, we can also design a text by attaching required symbol to the prefix and suffix of the text.

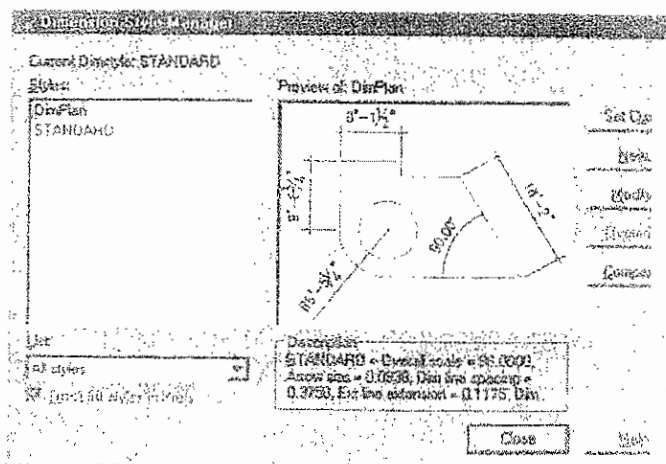
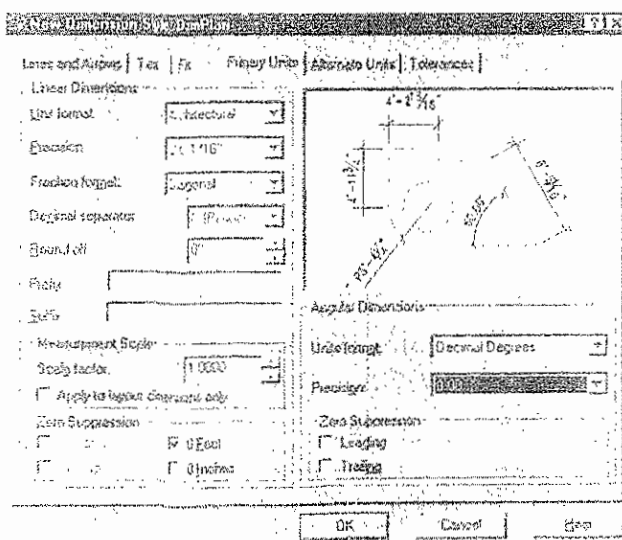

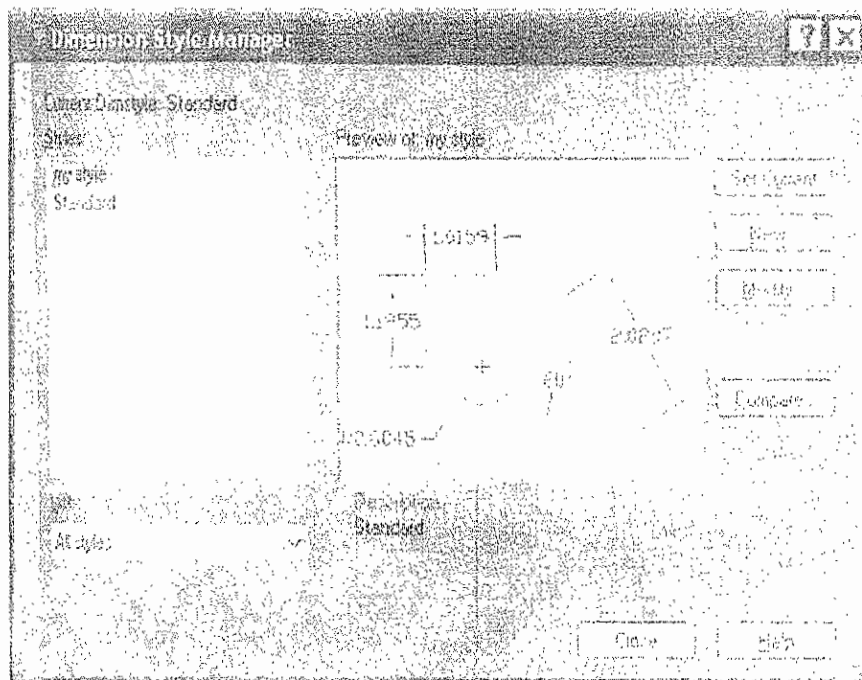
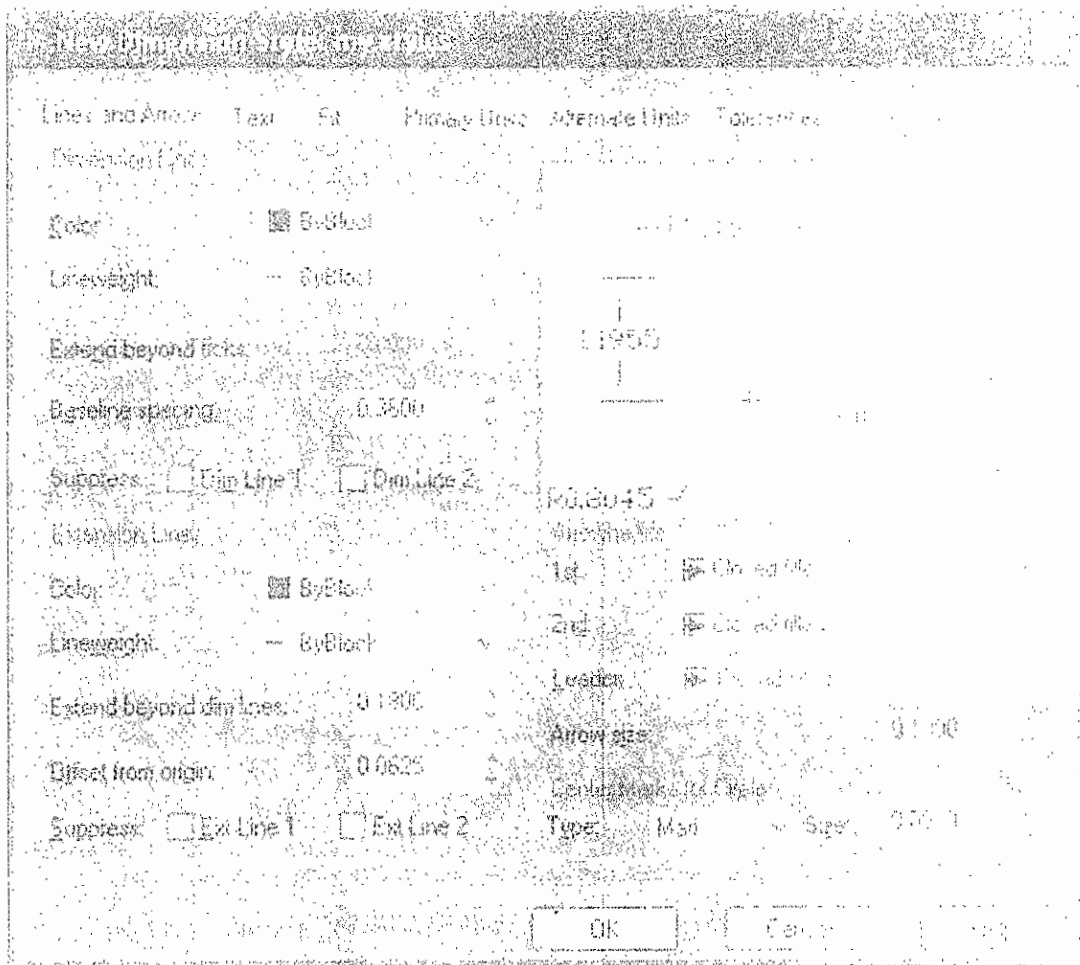

### Horizontal Justification

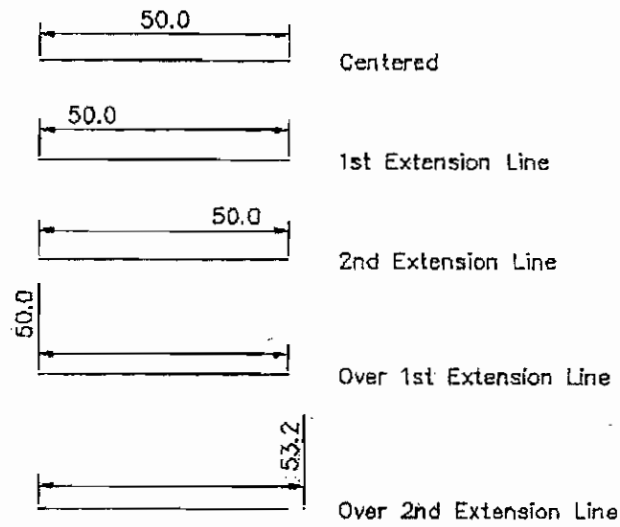

### Types of dimensioning

#### 1) Dimension linear

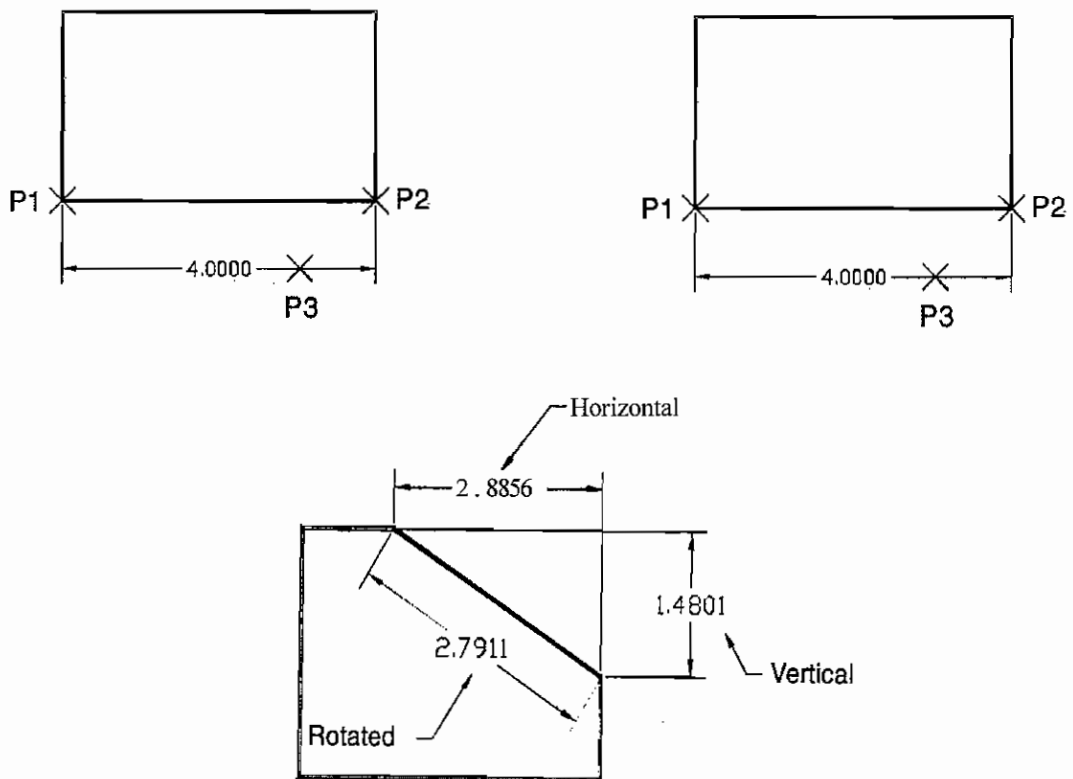

**2) Dim Aligned**

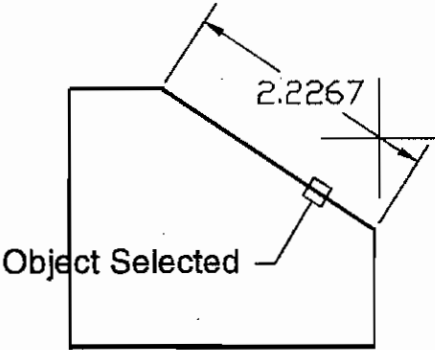

**3) Dim Radius**

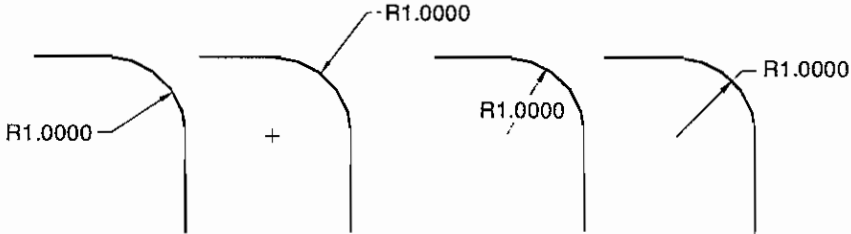

**4) Dim Diameter**

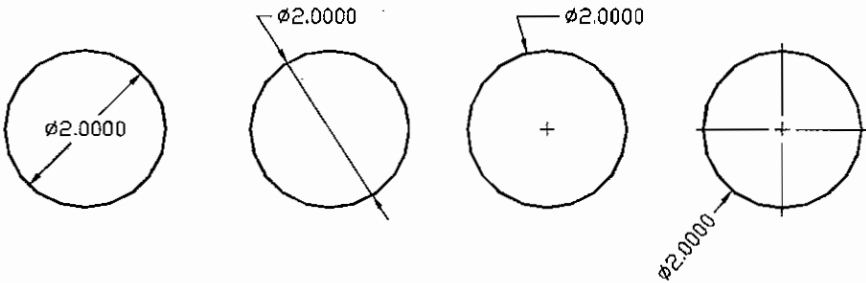

**5) Dim Centre**

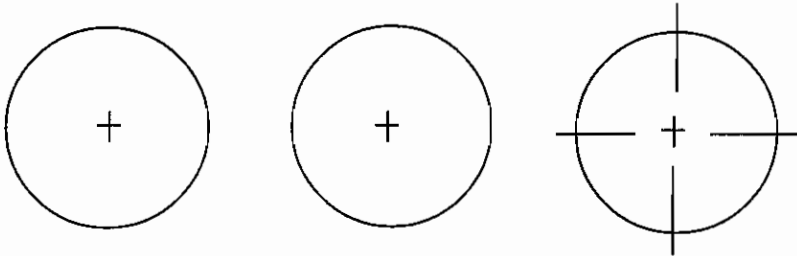

## 6) Dim Angular

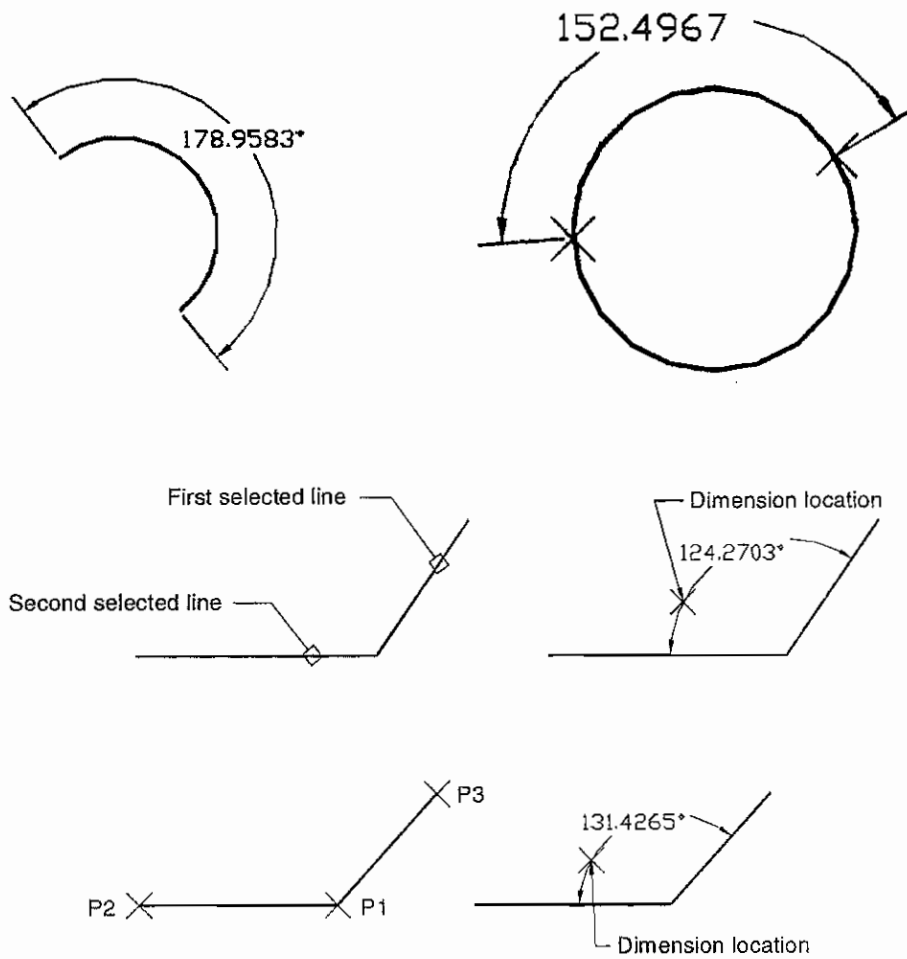

## 7) Dim baseline

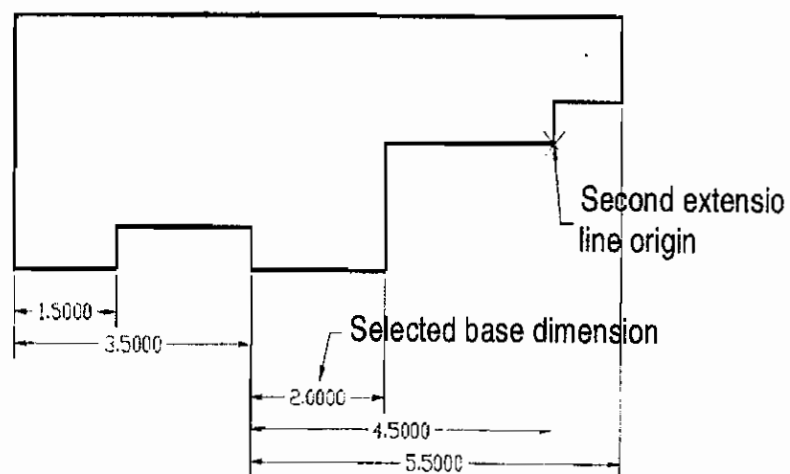



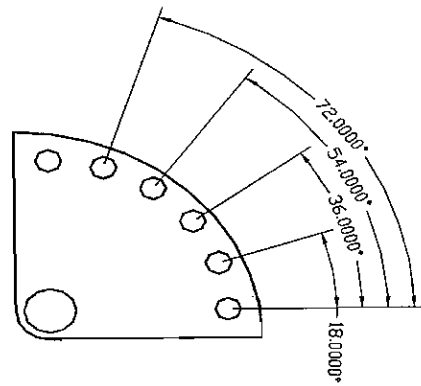
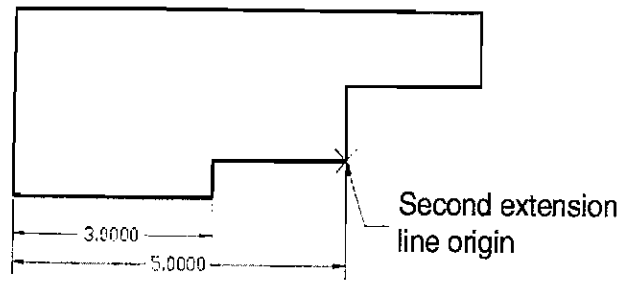

**8) Dim continue**

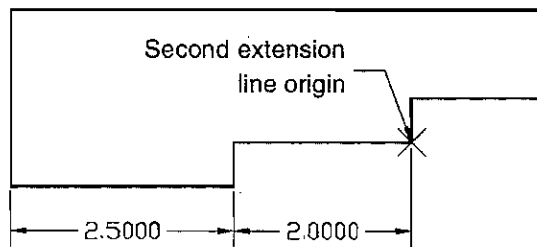

**9) Dim ordinate**

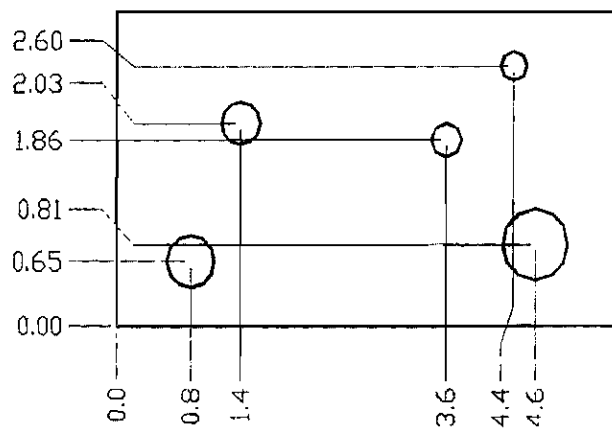

Form of dimensioning structure

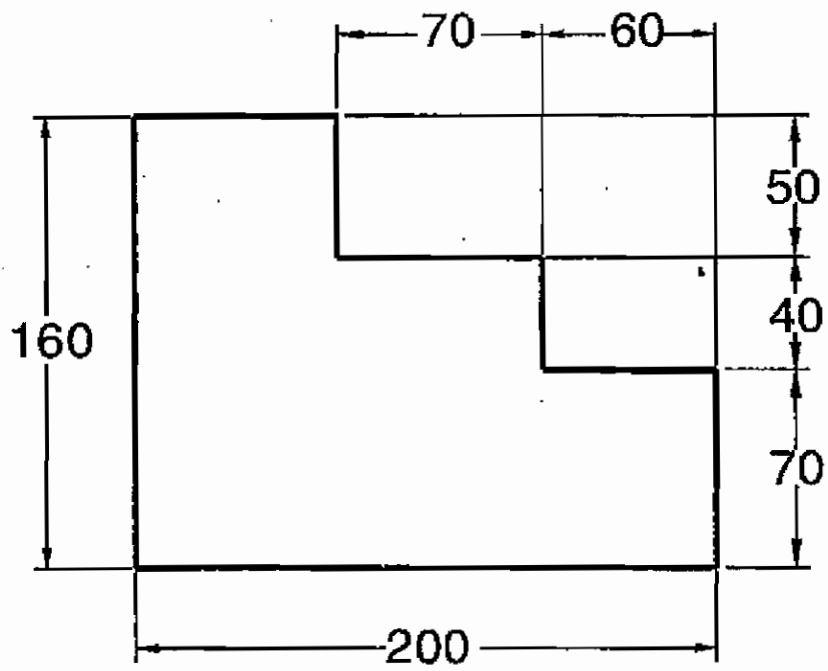
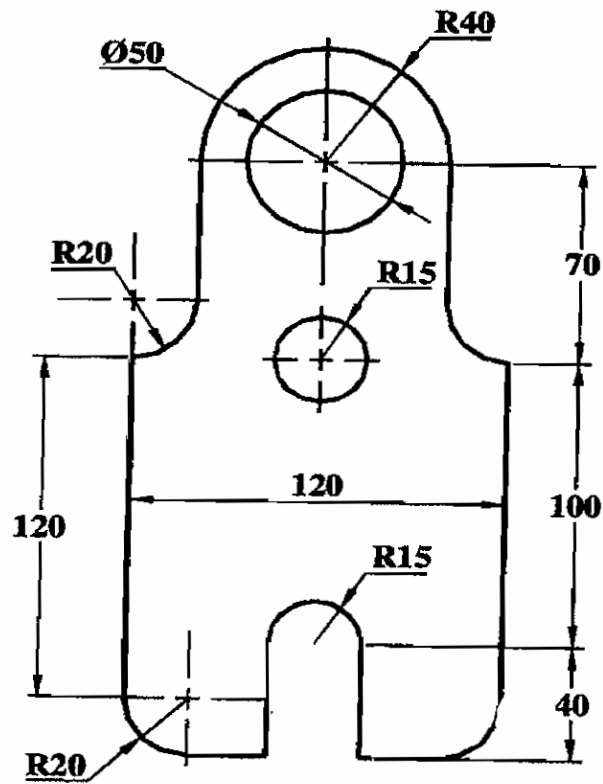

## 8.2.4 Layer

It is very tough to understand a drawing if we show the full details of the object in the same drawing when we prepare the manual drawing we will give the details of the drawing in several places of the object.

Also some structure do not require some details, so with other information another drawing is to be drawn.

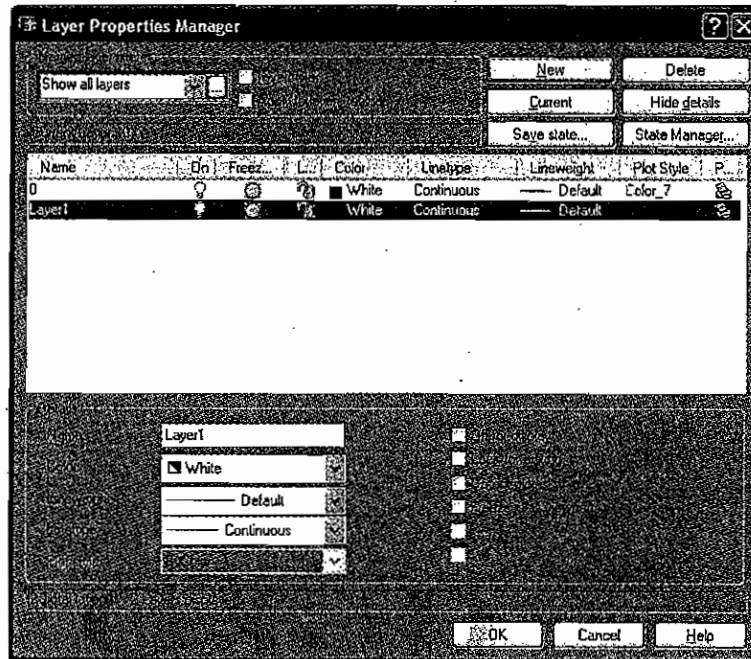
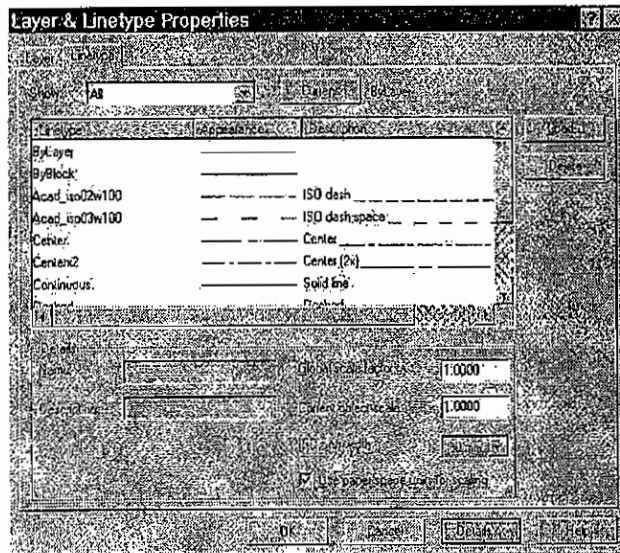

To eliminate this problem drawings are drawn in the layer method of Auto Cad. In this method we can take print out of the drawing object with required details. These layers are formed by giving a layer name.

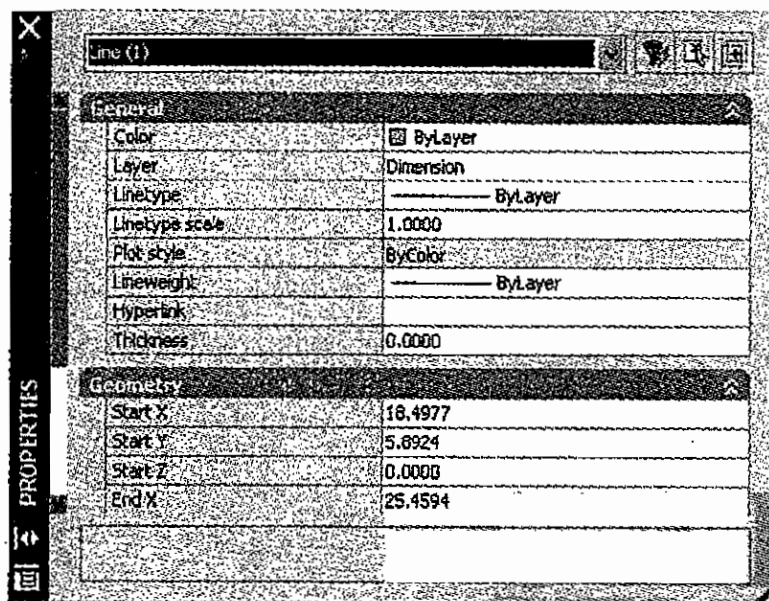
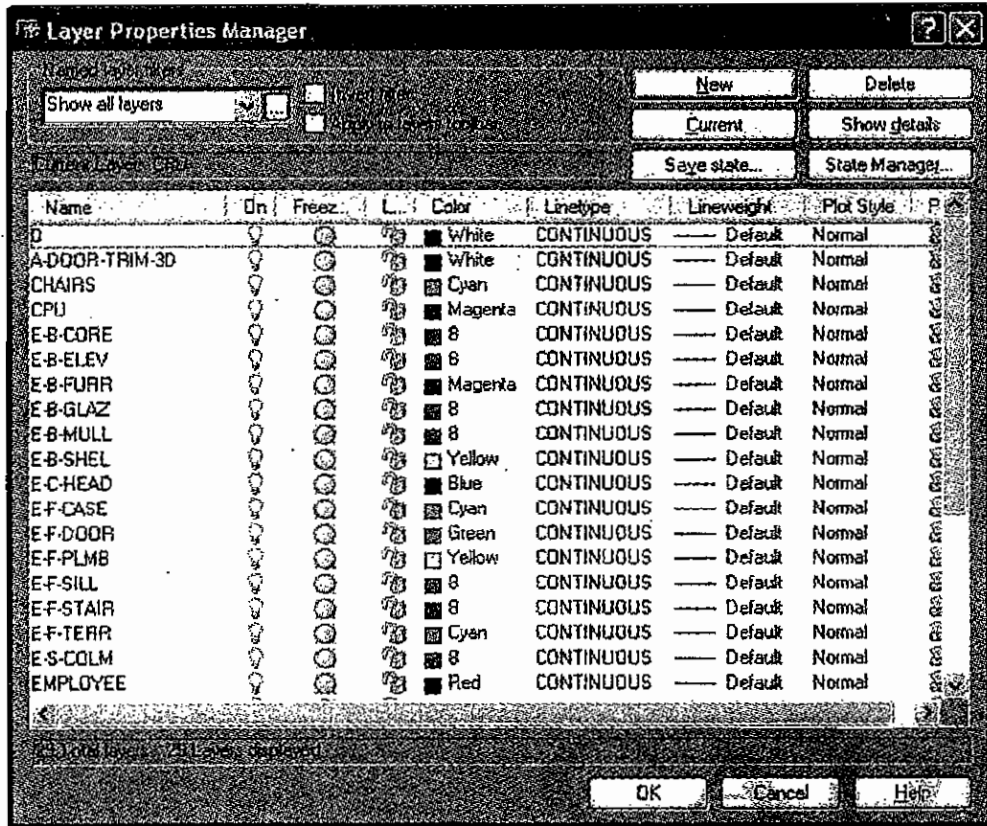

Options for on/off the layer, making freeze, Lock the layer are available in this command. Also each layer can be formed to a particular characteristic layer i.e., particular characteristic line type and colour are formed to those layers.

Assuming an architectural drawing is drawn in layer method. If foundation floors, electrical fitting, plumbing details are drawn in Individual layer. Print out of building plan may be taken when we switch on the required angle.

### Layer on/Off

This characteristic is used to switch off the unnecessary layer when we switch off the particular layer the drawing drawn in that layer will not be visible to our eyes.

Also that drawing cannot be printed (or) plotted. That layer may be switch on when required.

### Freeze

When we freeze a layer the objects in that layer are hidden. Also printing is not possible.

### Thaw

Opposite form of freeze take is thaw take. To operate the freezed layer again thaw is used.

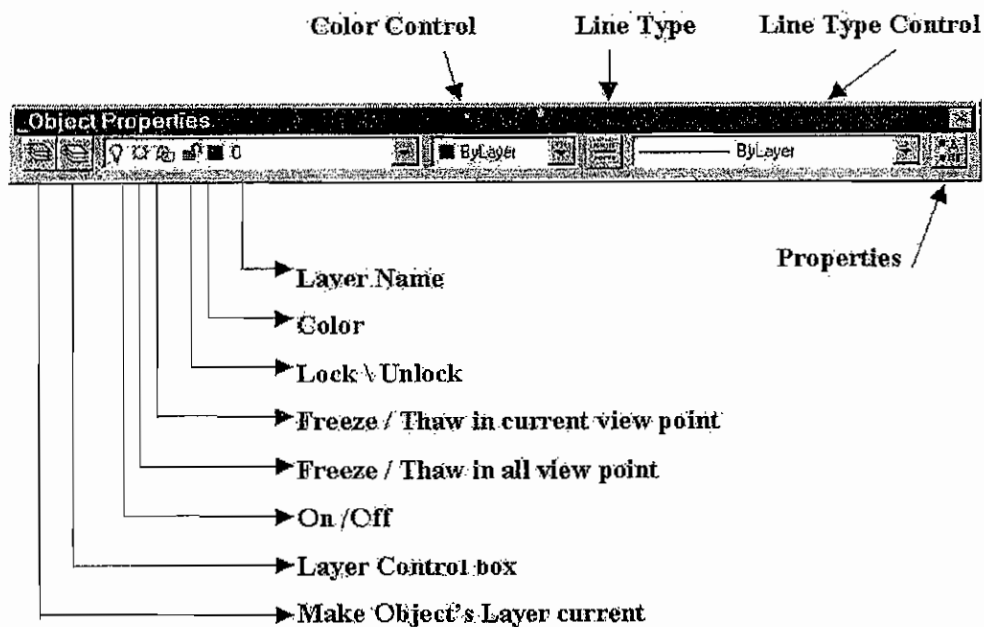

### Lock/Unlock

When we lock a particular layer the drawing in that layer will come to sight. The drawing in that layer attains the stage of impossibility of editing (or) selecting the drawing object in the locked layer cannot be erased. If we lock the layer after completing the drawing in a particular layer the drawing in that layer cannot be changed even by mistake.

## Unlock

If we press this take option selection of colour frame will appear. In that we can select the required colour. The drawing drawn in this layer will attain the colour we selected. So drawing should be drawn by giving separate colour to each layer colours are available from 1 to 255 types.

## Line type

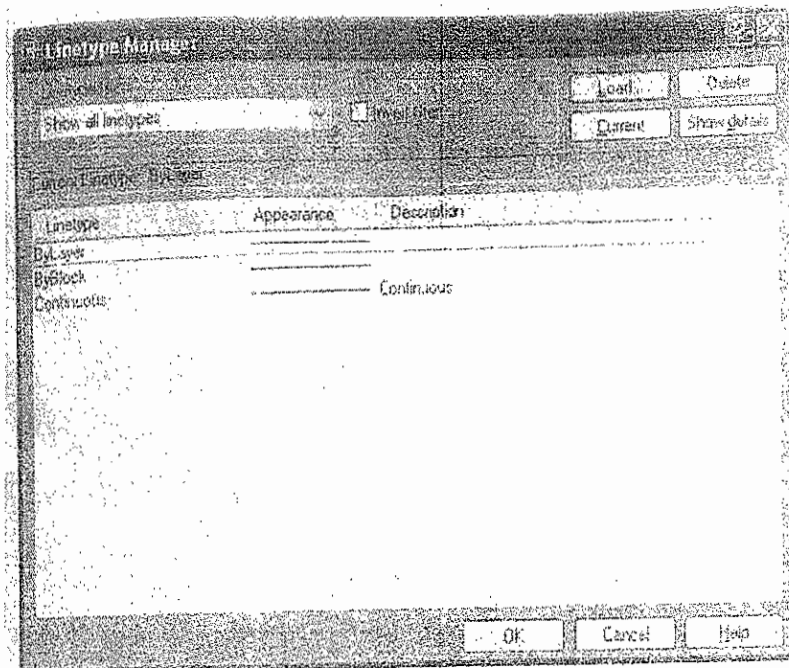
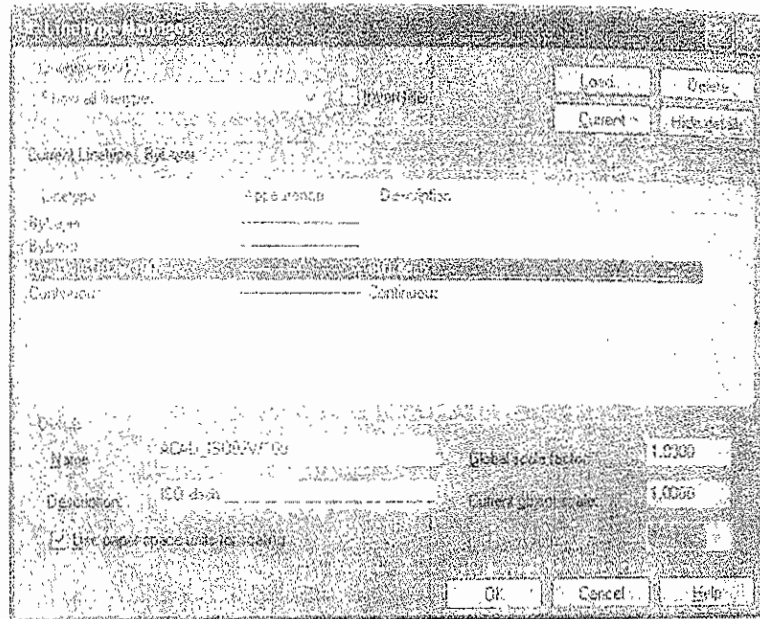

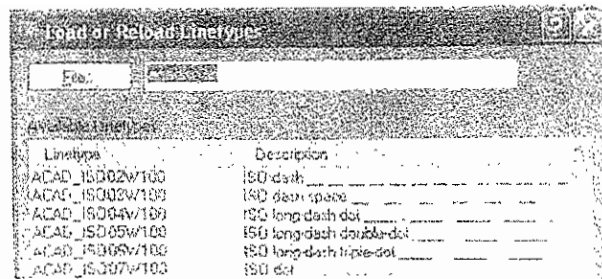

Above Figure will appear when we press this TAKE option several types of lines will appear in model structure.

Also we have to select several types of lines such as centre line, continuous line, hidden line, dashed line.

### Match properties

Assume the object in Dim layer is transferred to centre layer place the cursor in the object of centre layer then click the match properties button with the help of MOUSE BUTTON.

The characteristics changes the object in dim layer to centre layer.

Editing commands

### Regen

To renew a drawing which is already drawn this command is used. Sometimes the drawn object can be seen flat when we draw a circle (or) arc. Regen command is used to remove this flat formation.

### Explode

Objects of polyline regen polygon can be changed into individual object by using this command.

### Plotting Drawing

To make it use of the drawing we have drawn is copied in ordinary sheet (or) tracing sheet this command is used. There are two methods in copying such as printing and plotting. Printing is DOT MATRIX and used to take print in white sheet by inkjet and laser print. With this normally we can take print out in A3 and A4 sheet.

### Plot

Plot is nothing but taking tracing sheet print out in Indian Ink by Plotter instrument. We can plot upto AO size drawing. Drawings reproduced in tracing sheet and several copies are taken as blue print. Now colour plotters are available with this plotting may be carried out to photo print size.

While we are drawing a sketch to attain clarity and beauty we have to select the colours according to its thickness.

Clarity of drawing may also be obtained by selecting. Each pen to individual thickness and while plotting the drawing, selecting each colour to the each line thickness.

We can select the pen width in assignment part according to line type. Also the speed may be controlled according to the thickness.

### **Paper size and orientation**

In this part we can decide the paper for plotting (or) tracing size i.e., while the drawing is printed /plotted different size of papers are given to users and they can select according to requirement such as A4 size 210 mm x 297 mm.

We have to select the required size as per the text frame's width and height. Orientation of paper is according to breadth and width size. That is making convenient to the direction of landscape (or) portrait.

What ever may be size of drawing (e.g.) we have drawn A0 size, A0 size, Full scale, required size of drawing is produced when plotting is done. So this is a useful option.

### **Autocad**

Next plot rotation and origin dialogue box will display when we press Rotation and origin button. A radio button of circular angle 0°, 90°, 180°, 270° is there. By selecting this button, drawing is formed according to orientation of paper.

### **8.2.5 Isometric drawing**

Object drawn by ISOMETRIC DRAWING will be in VISUALIZING SHAPE. Full details of object with various view angle is shown in orthographic projection. But in ISOMETRIC VIEW we can see the visualizing form. We can give full details only when an object is drawn in orthographic view and isometric view.

### **Isometric projections**

Equal size view is Isometric view. Three axis of the object is seen in 180° angle.

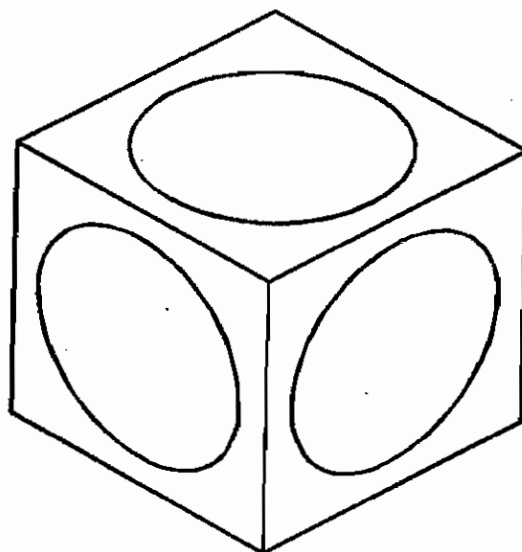



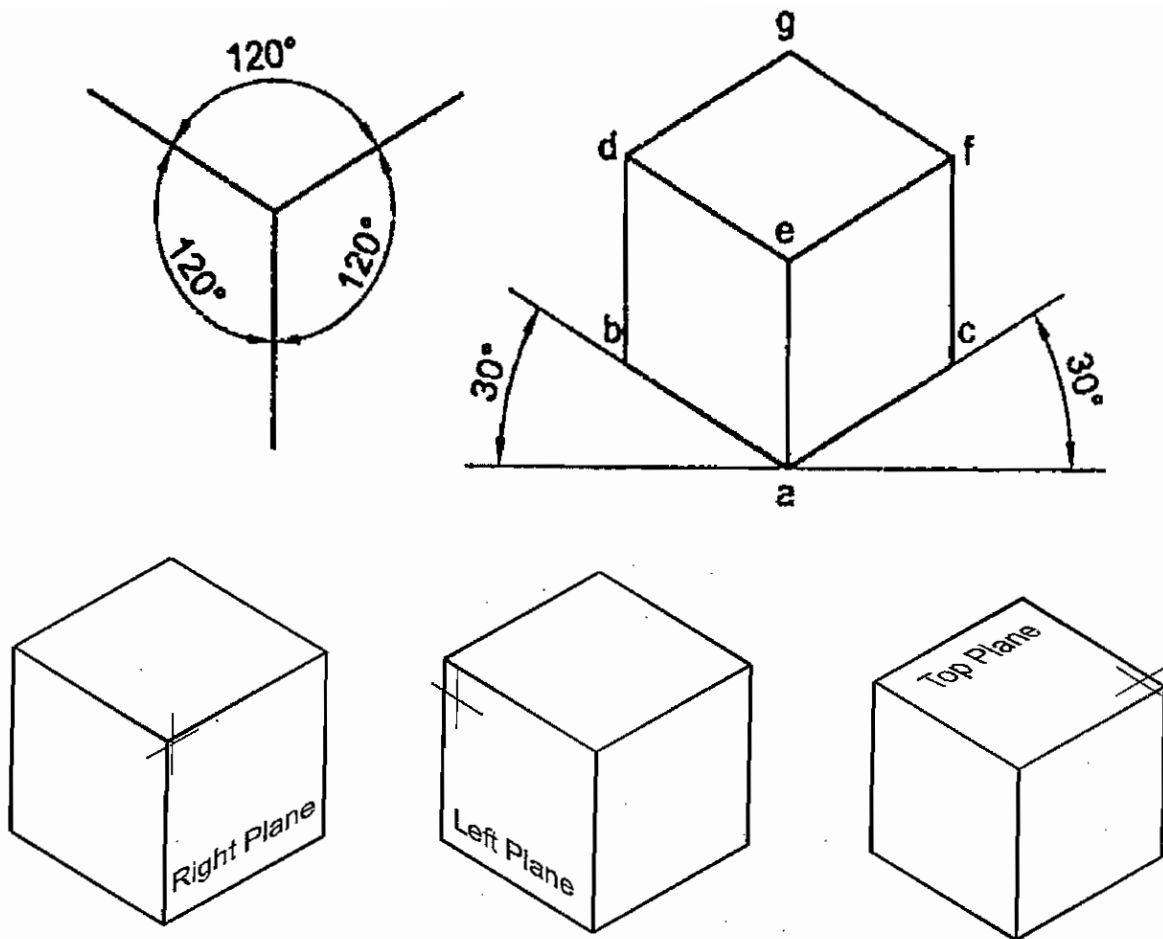

When we draw the drawing we have to use full scale. The hidden parts should not be drawn in hidden lines. The only visualizing shape of object will visible well.

We have to draw the drawing with 3 axis in this method.

Axis (Po, P1) drawn in horizontal position at 30° is called Right horizontal axis and the axis (Po, P3) is drawn at 30° angle to left side horizontal position is called left horizontal axis. In between these axis an axis (Po, P2) at 90° is also there, this is called vertical axis.

We have to change these 3 axis when we draw in ISOMETRIC drawing. That is cursor is moved to right axis and lines are drawn in that side. Then cursor is moved to left axis lines are drawn in that side. Like this upside lines are drawn by moving to vertical axis.

When Isometric Drawing is drawn the axis are changed and planes are drawn parallel to that axis. These are called isometric plane.

So, Isometric drawings are drawn with three planes of Right side plane, left side plane and top plane.

### Orthographic view

Drawing the visualizing shape of several angular shaped object in a drawing is called orthographic view.

Front view, top view, right side view, left side view, bottom view and Dimension of the drawing are drawn with the dimensional view of X, Y & Z axis.

When an object is on these three axis we have to imagine the angle of object and it is drawn on the drawing.

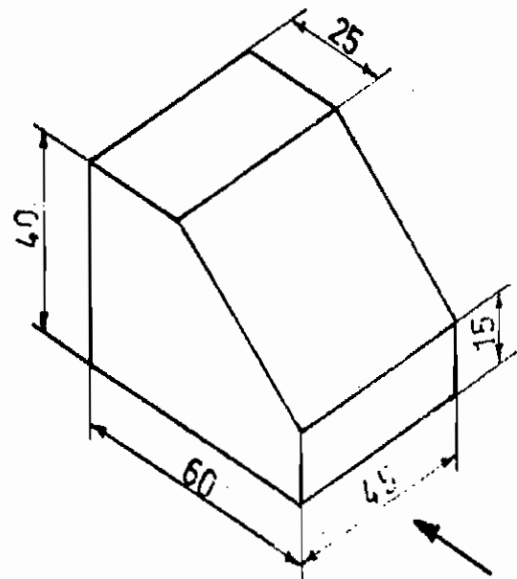
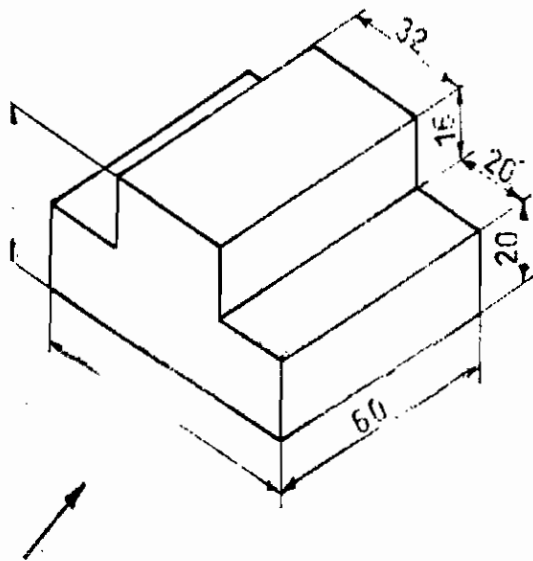
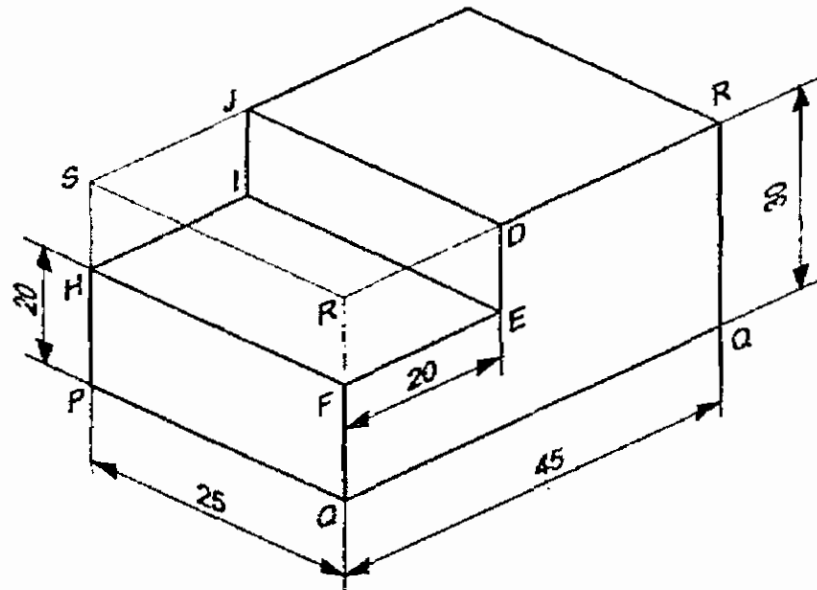

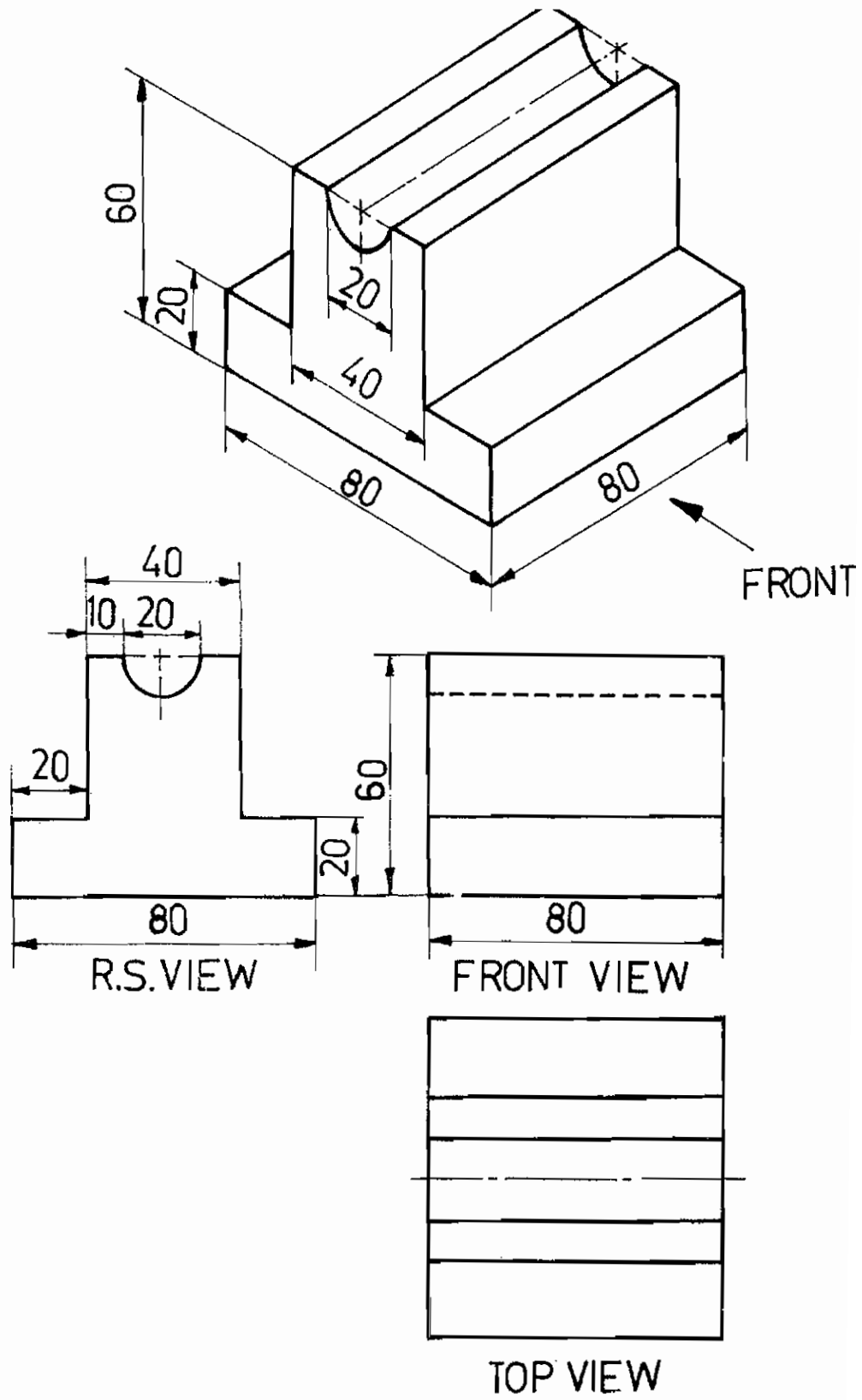

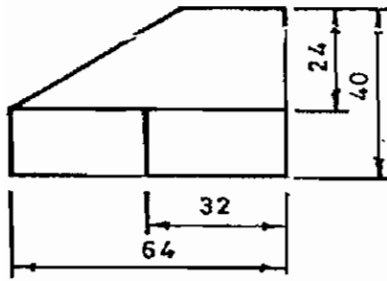
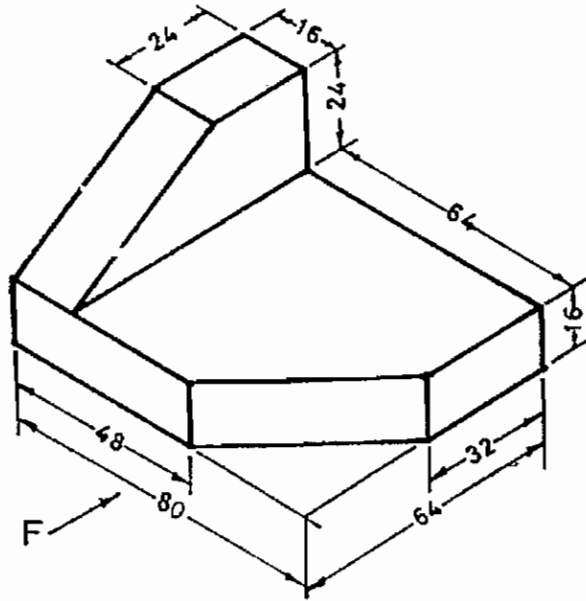

RIGHT SIDE VIEW

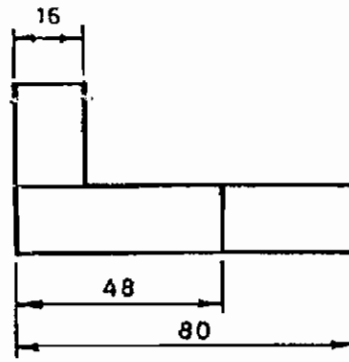

ELEVATION

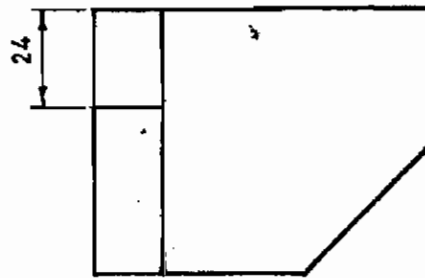

PLAN

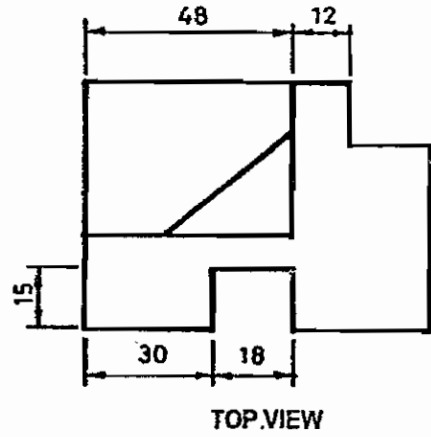
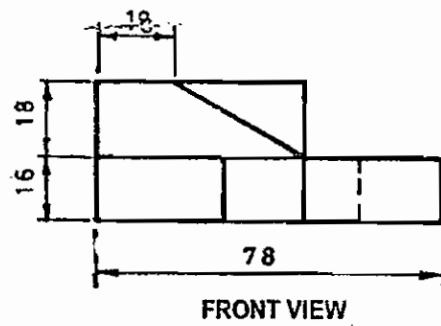
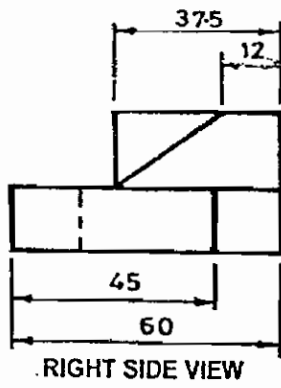
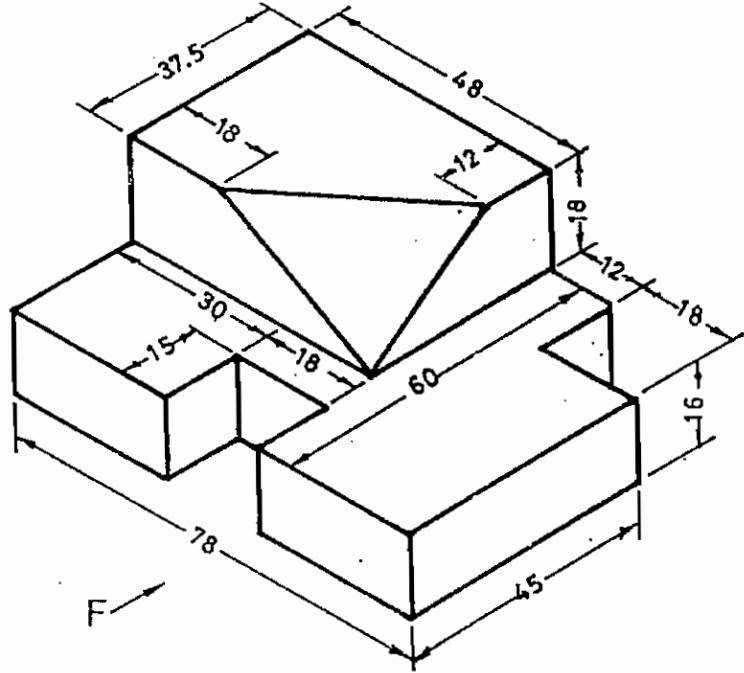

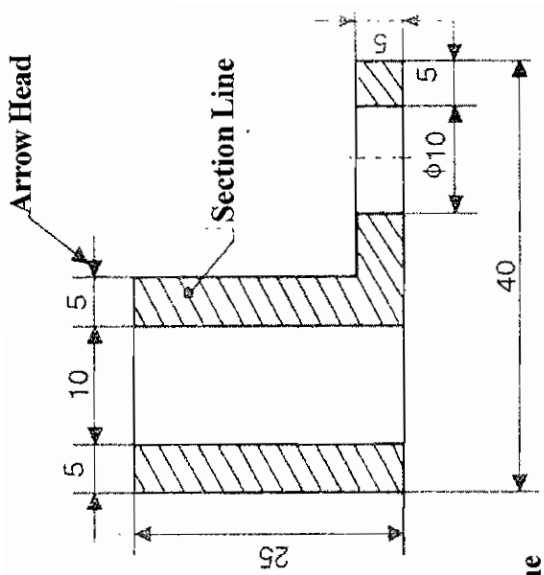

SECTIONAL FRONT VIEW

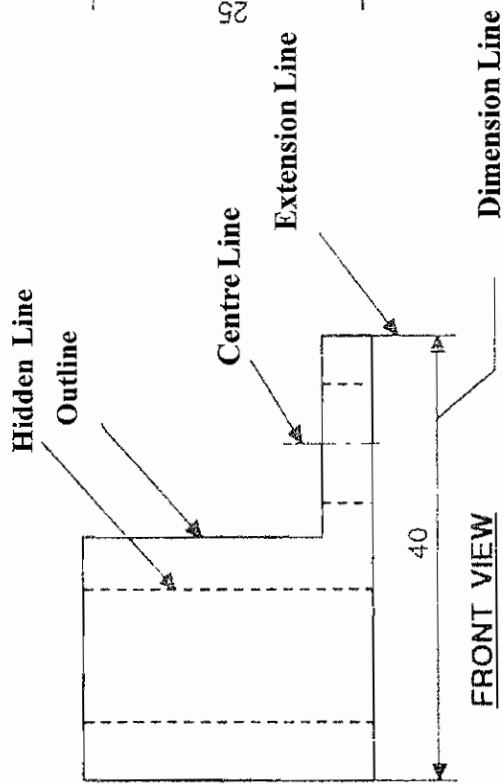

FRONT VIEW

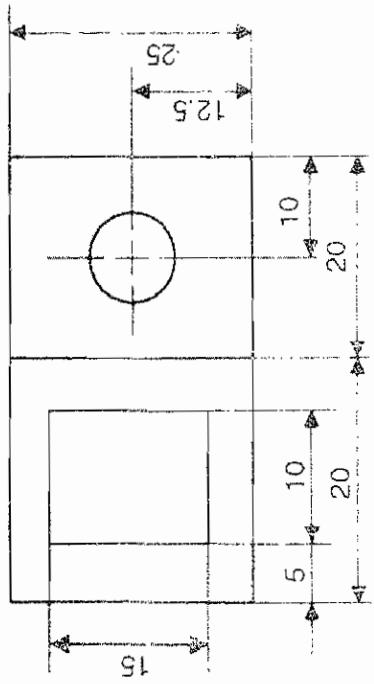

TOP VIEW

## QUESTIONS

### Part A

#### I. Choose the best answer

- 1) The command used to eliminate (or) erase an object  
a) Erase                      b) copy                      c) move                      d) offset
- 2) The command is useful to fasten the drawing and reducing the time of drawing.  
a) copy                      b) move                      c) offset                      d) mirror
- 3) The command used to rotate all the drawn object  
a) Move                      b) Rotate                      c) Hatch                      d) Trim
- 4) The command used to extend (or) reduce an object.  
a) Trim                      b) Extend                      c) Stretch                      d) Block
- 5) The command used to eliminate the middle part (or) part of edge.  
a) Block                      b) break                      c) Distance                      d) extent
- 6) The command used to change the wrongly typed words.  
a) text                      b) M text                      c) Editing text                      d) layer
- 7) The command used to visualize the object of large (or) small size.  
a) Array                      b) move                      c) Zoom                      d) copy
- 8) The command used to identify the type of line.  
a) Line                      b) Line type                      c) plot                      d) circle
- 9) The command used to take printout of a drawing in a tracing sheet.  
a) plot                      b) layer                      c) copy                      d) save
- 10) How many number of plane are there in Isometric drawing (or) three dimensional view.  
a) 5                      b) 4                      c) 3                      d)

### Part B

#### II. Answer in one (or) two words

- 1) Which command is used to move an object.
- 2) Which command is used to erase an object.
- 3) Which command is used to measure the distance between one point and another point.
- 4) Which command is used to take print of the drawn object.
- 5) In which paper object drawn are taken for print.

### **Part C**

#### **III. Answer in one (or) two sentences**

- 1) Define copy command.
- 2) What is mirror image
- 3) What is command 'offset'.
- 4) What is the command 'Rotate'.
- 5) What is the command 'Zoom'.

### **Part D**

#### **IV. Answer shortly**

- 1) Define the command Array.
- 2) What is dimensioning and define the three types.
- 3) Define the command layer or placing.

### **Part E**

#### **V. Answer in Detail**

- 1) What are the modify commands. Define any five.
- 2) What is the command dimensioning and define the types.



# **DRAUGHTSMAN CIVIL**

## **PRACTICAL I & II**

### **VOCATIONAL EDUCATION**

### **Higher Secondary - First Year**

A Publication under  
Government of Tamilnadu  
Distribution of Free Textbook Programme  
( NOT FOR SALE )

Untouchability is a sin  
Untouchability is a crime  
Untouchability is inhuman

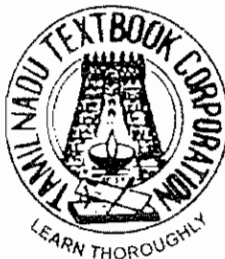

**TAMILNADU**  
**TEXTBOOK CORPORATION**  
College Road, Chennai - 600 006.

© Government of Tamilnadu  
First Edition - 2010

## **CHAIRPERSON**

**Mrs. M. SATHIAVENI**  
Chairperson  
Head of the Department (Civil)  
Central Polytechnic College,  
Tharamani, Chennai - 600 113.

## **AUTHORS**

**Mr. K. Senthilvelan**  
Vocational Teacher  
General Cariappa Hr. Sec. School  
Saligramam, Chennai - 600 093.

**Mrs. S. Deepa Patchiammai**  
Vocational Teacher  
NLC Girls Hr. Sec.School  
Block 11, Neyveli - 607 803.

**Mr. R. Ravi**  
Vocational Teacher  
Sengunthar Magasana Hr. Sec. School  
Tharamangalam,  
Salem Dist. - 636 502

**Mr. A.Tamilselvan**  
Vocational Teacher,  
RN. Govt. Boys Hr. Sec. School  
Aykkaran Pulam 2  
Nagai Dist. - 614 707.

**Mr. V.V. Balaji, B.E.,**  
Vocational Teacher  
Govt. Hr.Sec.School,  
Mettur Dam  
Salem Dist. - 636 401

This book has been prepared by The Directorate of School Education  
on behalf of the Government of Tamilnadu

**This book has been printed on 60 GSM Paper**

Printed by Offset at:

## **Syllabus**

### **PRACTICAL I (DRAWING)**

#### **DRAWINGS THROUGH MANUAL AND AUTOCAD**

##### **BASIC ENGINEERING DRAWING**

01. i. Lettering and Numbering Practice  
ii. Dimensioning Practice
02. Line techniques and circles
03. Geometrical construction  
Bisecting a line – Perpendicular - Division of line – Angles – Square
04. Conic Sections - Ellipse, Parabola and Hyperbola
05. Conventional symbols of materials
06. Symbols for Doors and Windows
07. Symbols for Sanitary fittings
08. Symbols for Electrical Fittings
09. Isometric view & Orthographic projections - Model – I
10. Isometric view & Orthographic projections - Model – II

##### **CIVIL ENGINEERING DRAWING**

11. Bond in Brick work – Right Angled (English Bond (or) Flemish Bond)
12. Section of Foundation (Types of footings of wall and foundation details for steps and wall)
13. Arches (Flat, Semi circular, Elliptical and Segmental Arch)
14. Panel door

## **SYLLABUS**

### **PRACTICAL II (LAB)**

01. Determine the Normal consistency of the given cement sample
02. Determine the Initial Setting time of the given cement sample.
03. Determine the Fineness value of the given cement sample
04. Determine the VOIDS RATIO of the given sand sample.
05. Determine the POROSITY of the given sand sample.
06. Determine the BULK DENSITY of the given sand sample.
07. Water absorption test on coarse aggregate.
08. Water absorption test on Brick.
09. Setting out work for a single room building for foundation.
10. Construct a Brick masonry in English bond for a one brick wall.
11. Construct a Brick masonry in Flemish Bond for a one brick wall.
12. White and colour washing for a plastered surface
13. Study of steel fabrication for a Lintel.
14. Study of steel fabrication for a one way slab.

## **PREFACE**

The task of Engineering studies is sky High. For which Civil Engineering students should have the relevant books for their need. Civil Engineering is a Universal Subject function without this faction.

Imparting Technical Education in school level have been started in 1978. Draughtsman Civil and Building Maintenance are combined in this book.

Basic Engineering Drawing, Building Materials and Practice and AUTO CAD are interlinked in one day to day life.

Understanding the concept of Civil Department syllabus, this book has been prepared in detail in each chapter with due importance are given to clear diagrams and questions.

Now the situation has changed by imparting Technical Education only through Engineering Colleges. At present, students who have studied in Vocational groups are deserved to admission at Polytechnic and Job opportunity are bright.

I must sincerely convey my thanks esteemed to the school Education Director and Joint Director whose partonage on this book to comeout and the committee of learned Teachers who shouldered the responsibility to bring the book in good shape.

The student community will appreciate and take lead of the task to modern world.

**M. SATHIAVENI**

Chairperson

**CONTENT**  
**PRACTICAL I (DRAWING)**

<b>S.No.</b>	<b>Name of the Exercise</b>	<b>Page No.</b>
<b>DRAWINGS THROUGH MANUAL AND AUTOCAD</b>		
<b>Basic Engineering Drawing</b>		
01.	i. Lettering and Numbering Practice	2
	ii. Dimensioning Practice	6
02.	Line techniques and circles	8
03.	Geometrical construction	11
	Bisecting a line – Perpendicular - Division of line – Angles – Square	
04.	Conic Sections - Ellipse, Parabola and Hyperbola	15
05.	Conventional symbols of materials	19
06.	Symbols for Doors and Windows	20
07.	Symbols for Sanitary fittings	21
08.	Symbols for Electrical Fittings	22
09.	Isometric view & Orthographic projections - Model – I	23
10.	Isometric view & Orthographic projections - Model – II	24
<b>Civil Engineering Drawing</b>		
11.	Bond in Brick work – Right Angled (English Bond (or) Flemish Bond)	25
12.	Section of Foundation (Types of footings of wall and foundation details for steps and wall)	29
13.	Arches (Flat, Semi circular, Elliptical and Segmental Arch)	32
14.	Panel door	35

## CONTENT

### PRACTICAL II - LAB

S.No.	Name of the Exercise	Page No.
01.	Determine the Normal consistency of the given cement sample	41
02.	Determine the Initial Setting time of the given cement sample	43
03.	Determine the Fineness value of the given cement sample	45
04.	Determine the VOID RATIO of the given sand sample.	46
05.	Determine the POROSITY of the given sand sample.	48
06.	Determine the BULK DENSITY of the given sand sample.	50
07.	Water absorption test on coarse aggregate.	52
08.	Water absorption test on Brick.	53
09.	Setting out work for a single room building for foundation.	54
10.	Construct a Brick masonry in English bond for a one brick wall.	56
11.	Construct a Brick masonry in Flemish Bond for a one brick wall.	58
12.	White and colour washing for a plastered surface	60
13.	Study of steel fabrication for a Lintel.	61
14.	Study of steel fabrication for a one way slab.	63

**PRACTICAL I**  
**(DRAWING)**



01. I. LETTERING AND NUMBERING PRACTICE

VERTICALTYPE

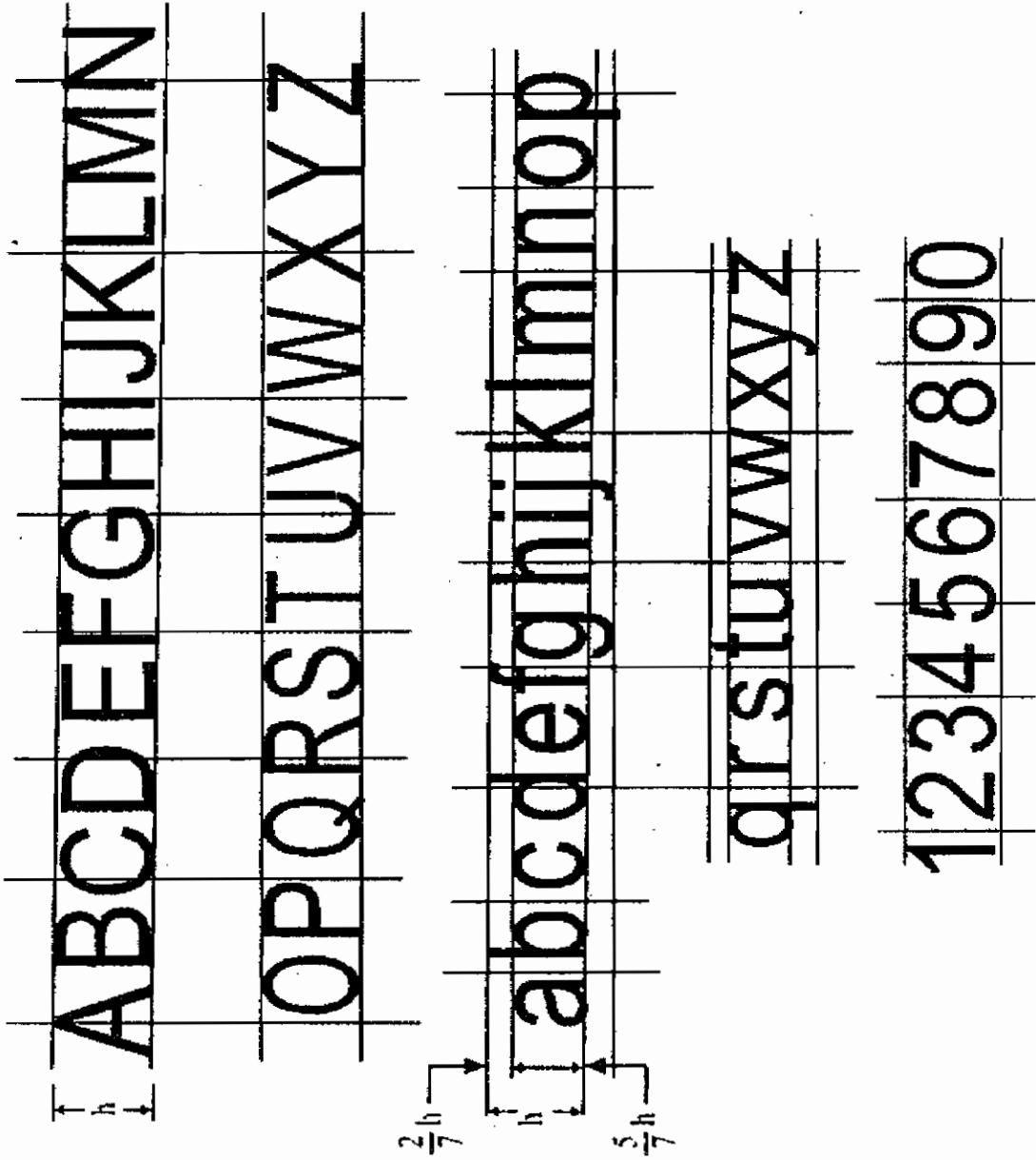

INCLINED TYPE

A B C D E F G H I J K L M N

O P Q R S T U V W X Y Z

a b c d e f g h i j k l m n o p

q r s t u v w x y z

1 2 3 4 5 6 7 8 9 0

**DOUBLE STROKE LETTERING**

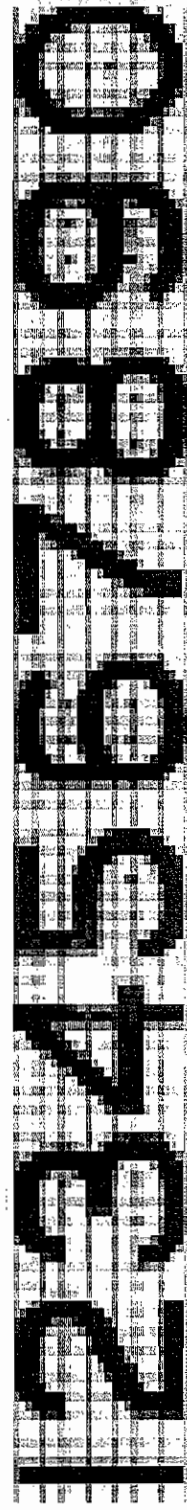
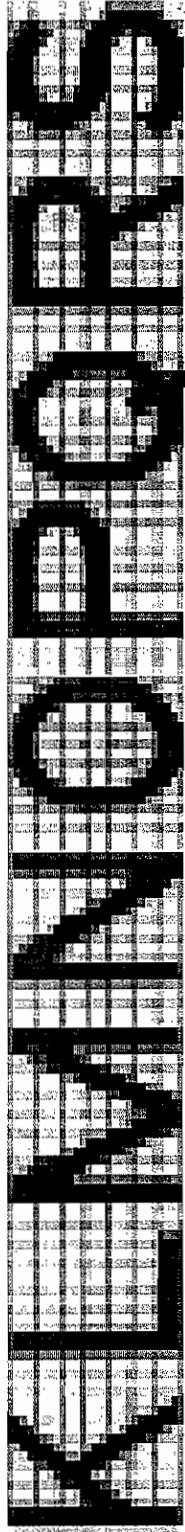

# IMPORTANT POINTS FOR BASIC DRAWINGS

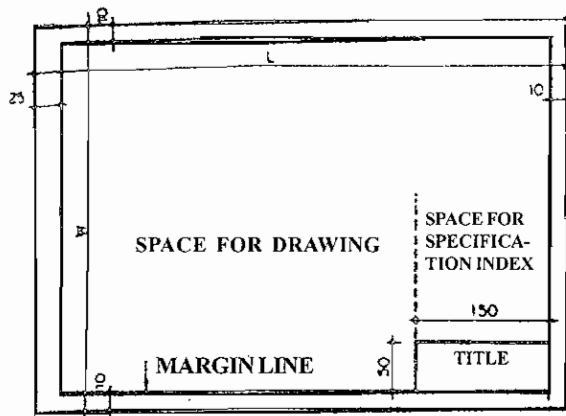

SIZE	W (mm)	L (mm)	A (m <sup>2</sup> )
A0	841	1189	1.00
A1	594	841	0.50
A2	420	594	0.25
A3	297	420	0.125
A4	210	297	0.063

## SIZE AND LAYOUT OF DRAWING SHEET

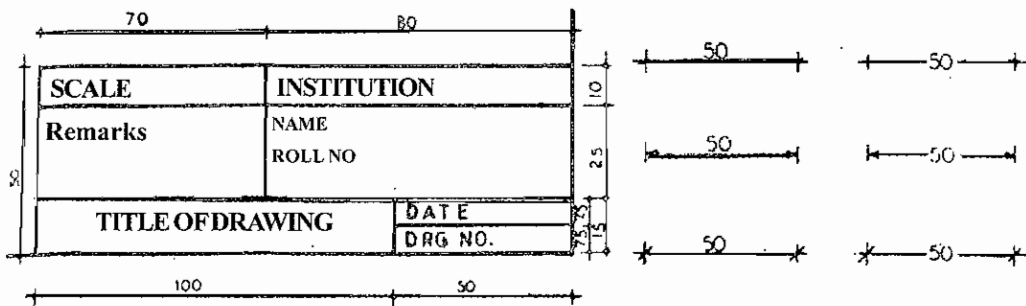

## DETAILS OF TITLE BLOCK

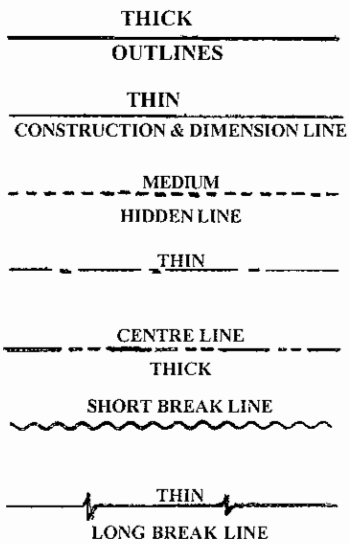

## DIFFERENT TYPES OF LINES USED IN CONSTRUCTION DRAWINGS

## METHODS OF DIMENSIONING

ALL DIMENSIONS ARE IN MILLIMETRES

## II. DIMENSIONING PRACTICE

### ALIGNED SYSTEM

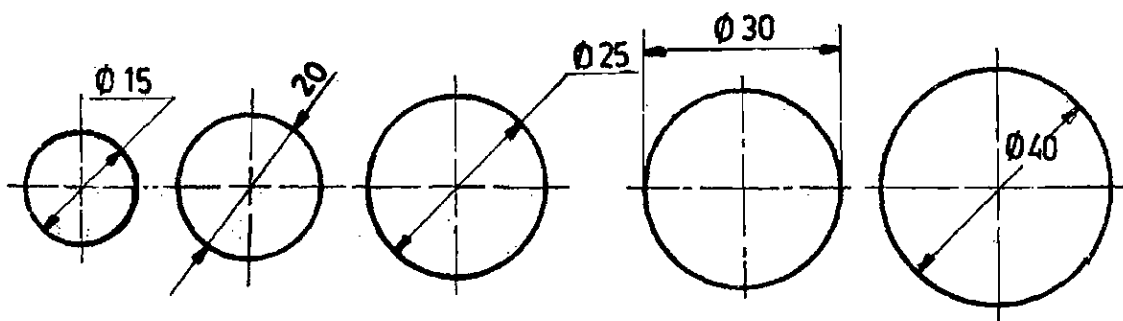
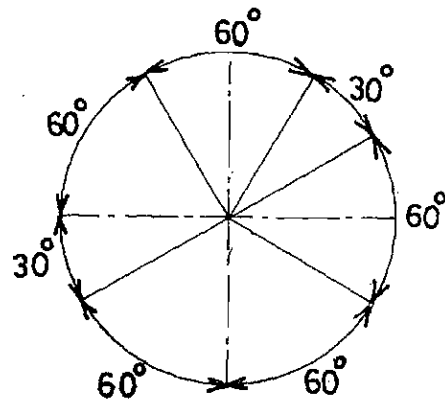
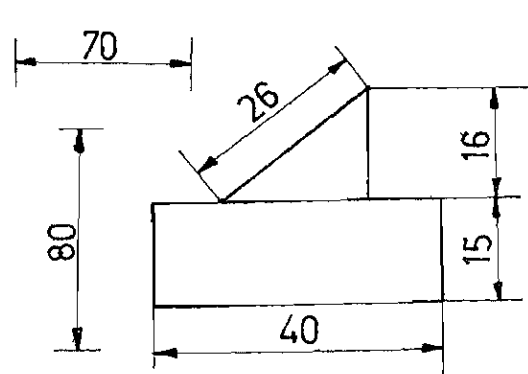
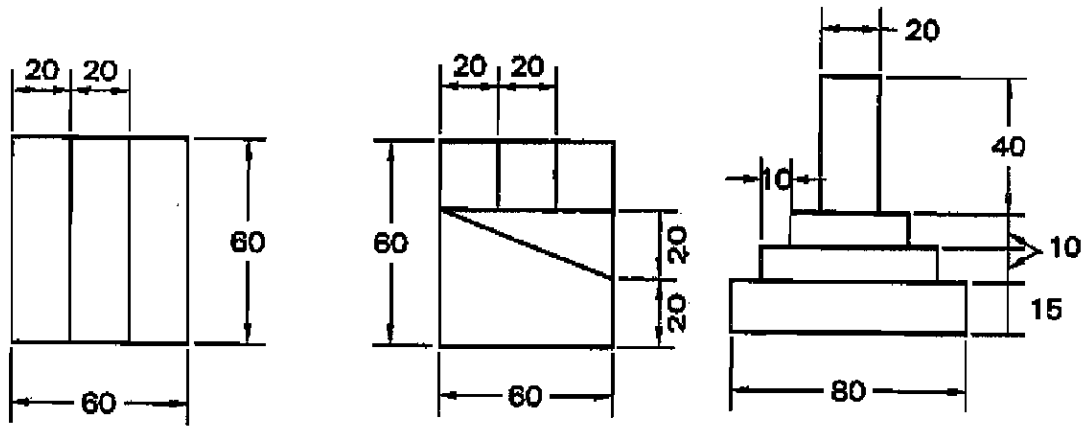

ALL DIMENSIONS ARE IN MILLIMETRES

# DIMENSIONING PRACTICE

## UNI-DIRECTIONAL SYSTEM

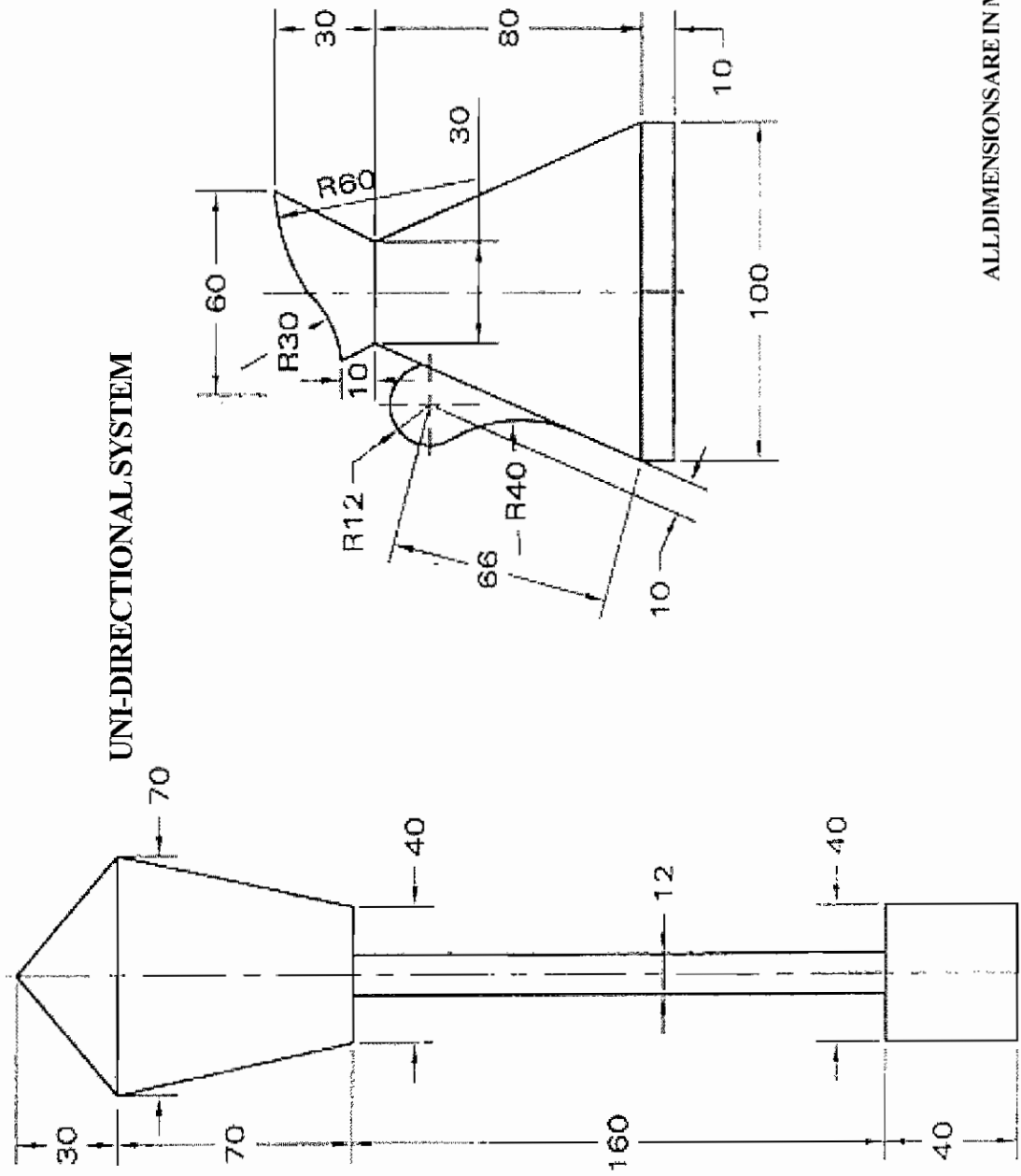

ALL DIMENSIONS ARE IN MILLIMETRES

## 2. LINE TECHNIQUES & CIRCLES

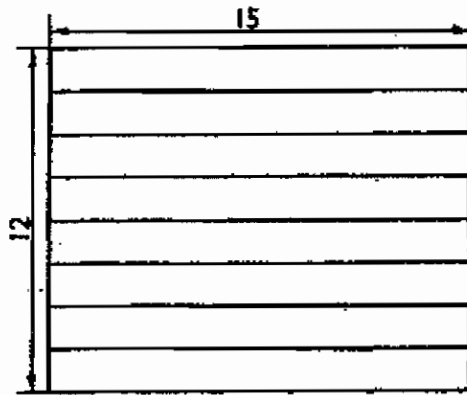

HORIZONTAL LINES

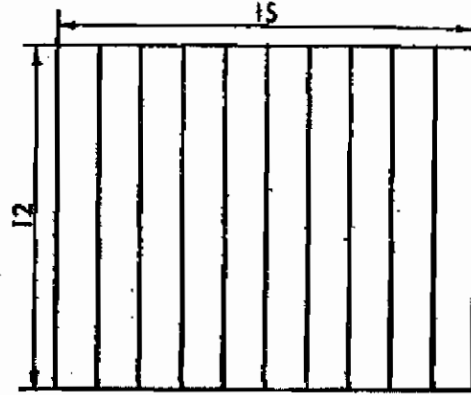

VERTICAL LINES

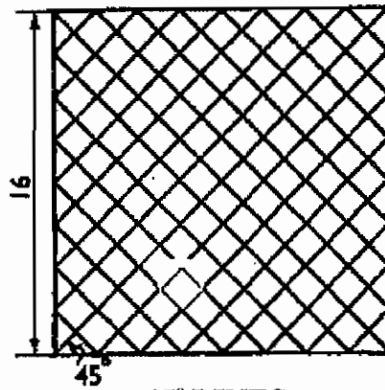

45° LINES

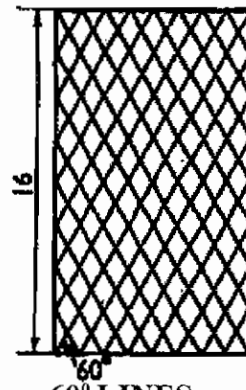

60° LINES

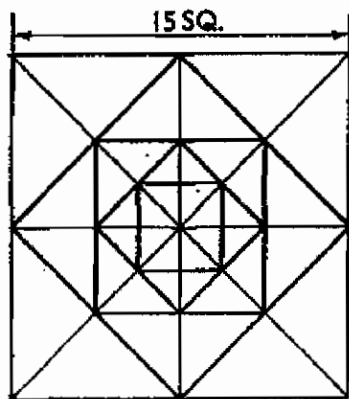

SQUARE IN SQUARES

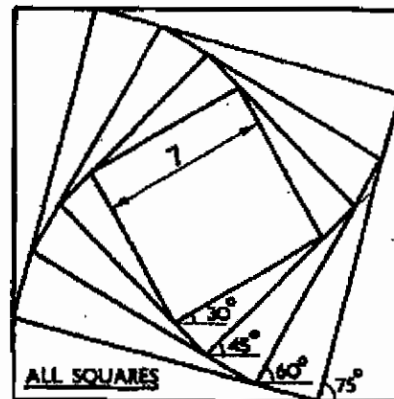

ALL SQUARES

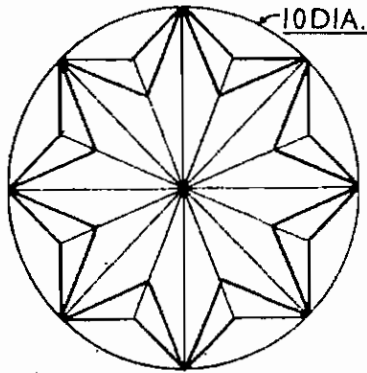

**CIRCLE AND DESIGN**

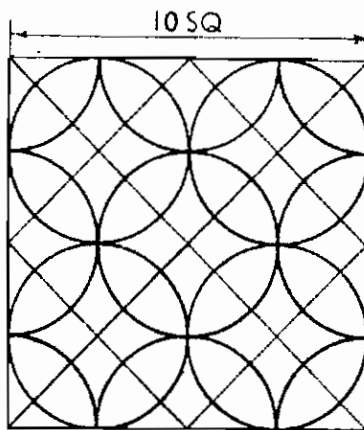

**SQUARE IN CIRCLES**

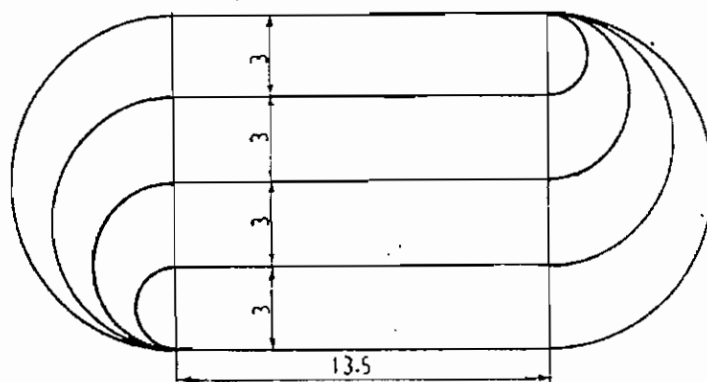

**RECTANGLE CIRCLES**



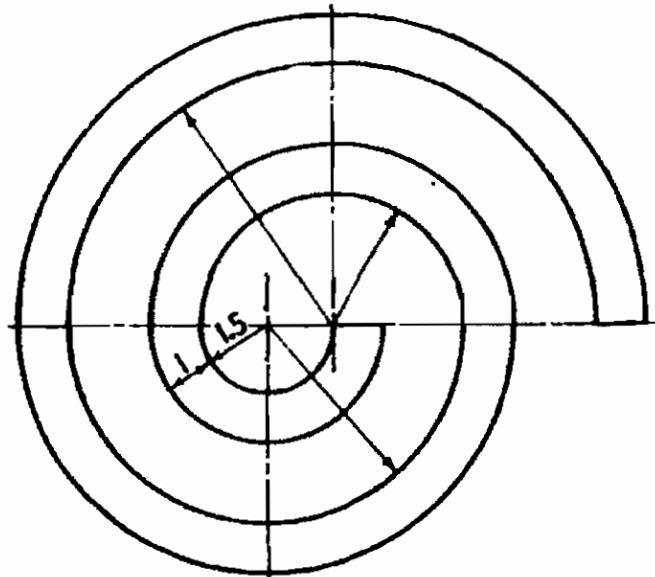

CONTINOUS ARC

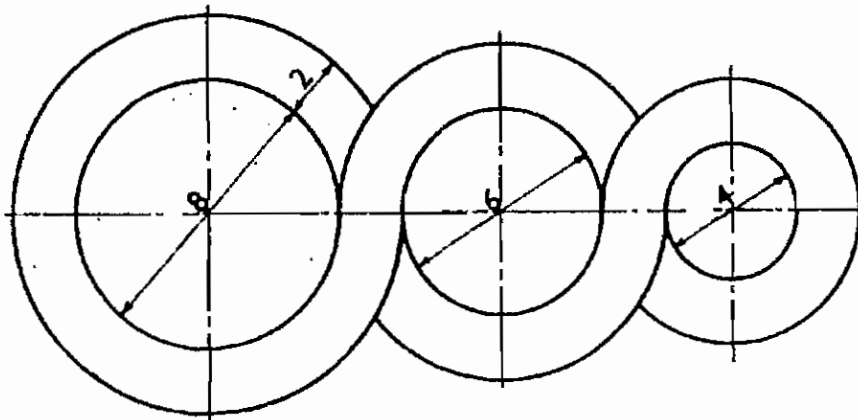

COMBINED CIRCLES

03. GEOMETRICAL CONSTRUCTION

BISECTING A LINE – PERPENDICULAR - DIVISION OF  
LINE – ANGLES – SQUARE

GEOMETRICAL CONSTRUCTION

BISECTING A LINE

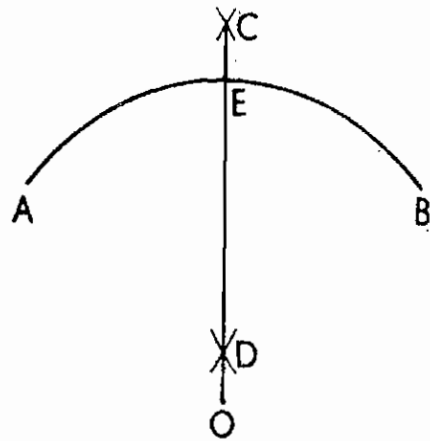
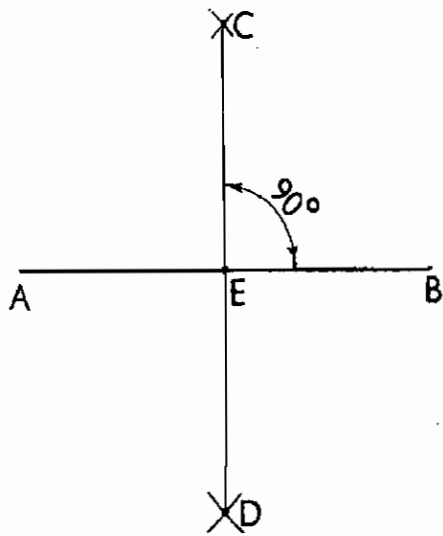

PERPENDICULAR

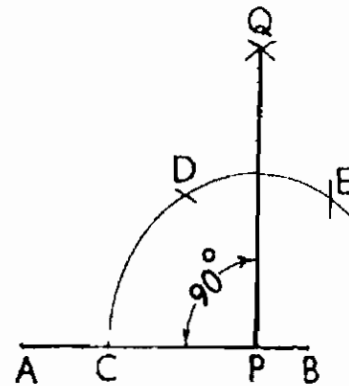
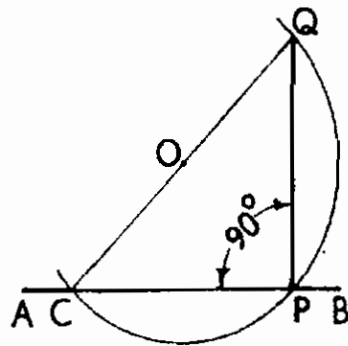
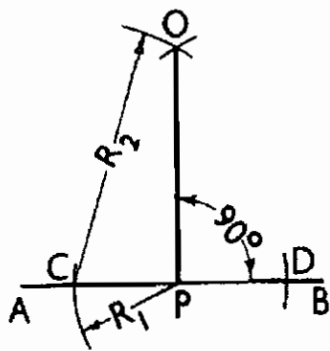

DIVISION OF LINE

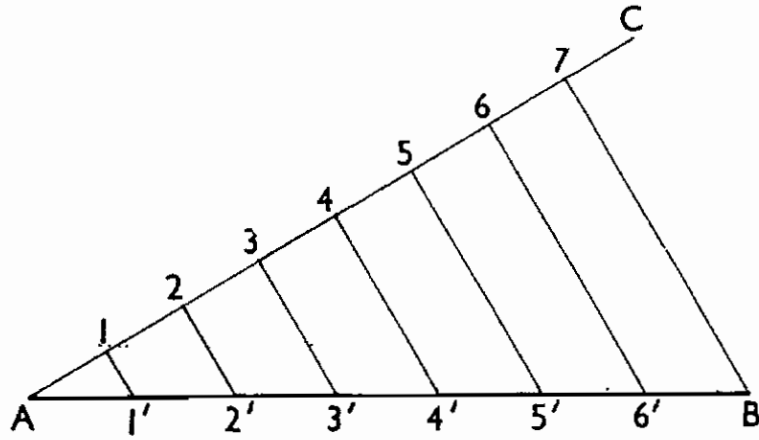

ANGLES

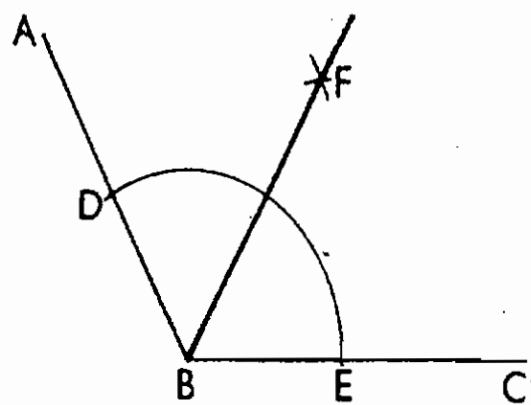
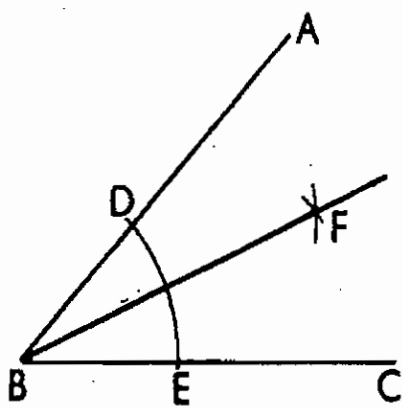

ANGLES

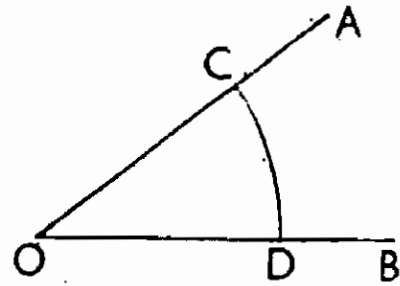
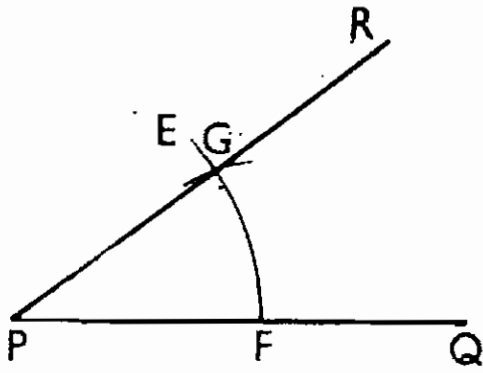

ANGLES

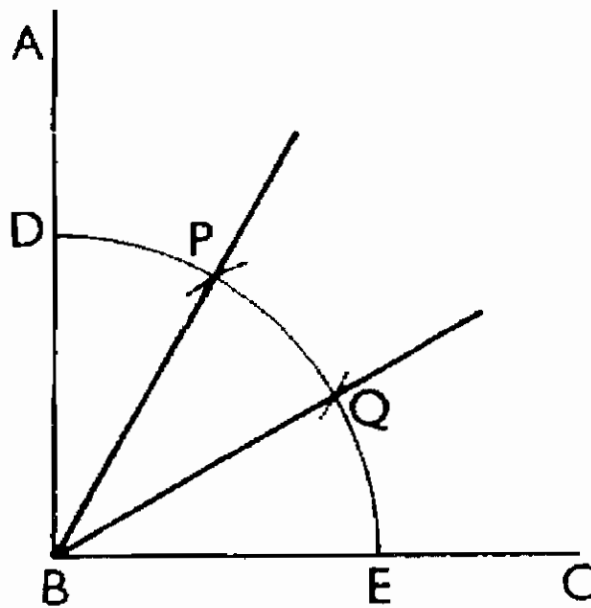

TRIANGLES

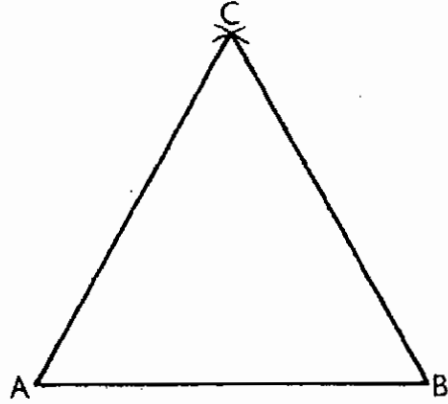
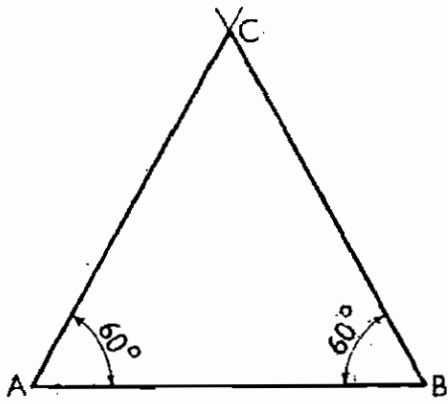

SQUARES

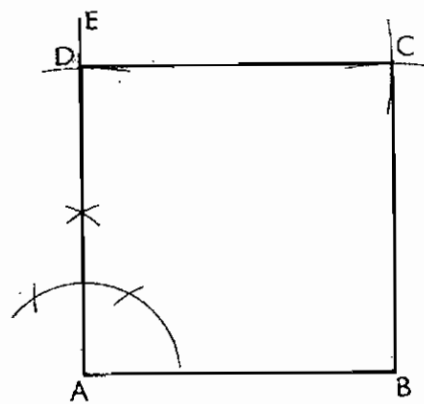
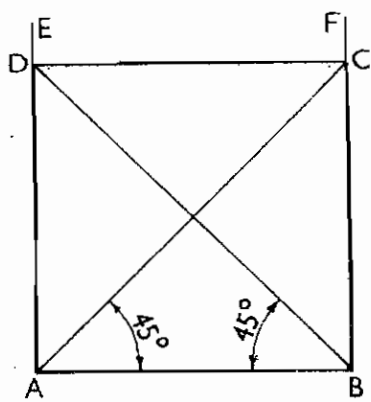

04. CONIC SECTIONS - ELLIPSE, PARABOLA AND HYPERBOLA

CONIC SECTIONS

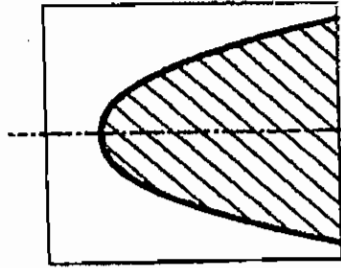

HYPERBOLA

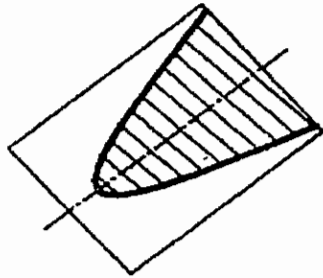
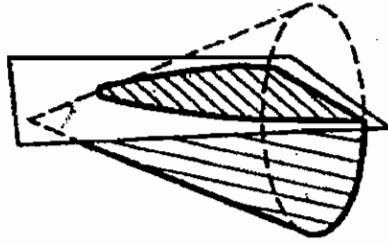

PARABOLA

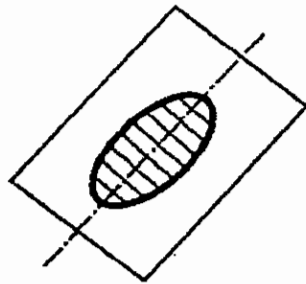
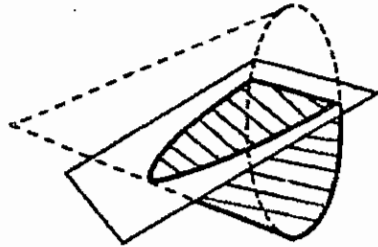

ELLIPSE

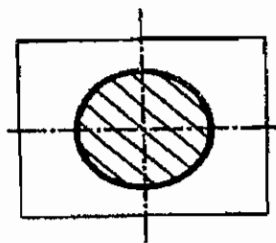
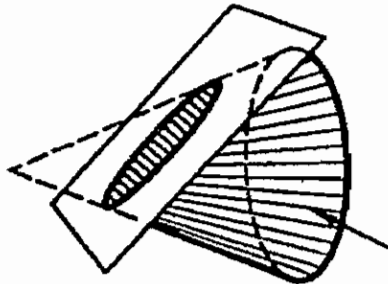

CIRCLE

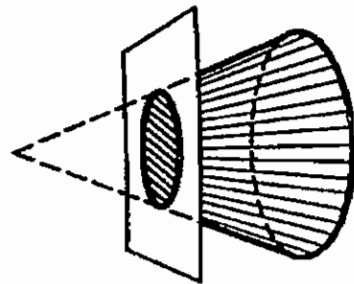

**ELLIPSE**

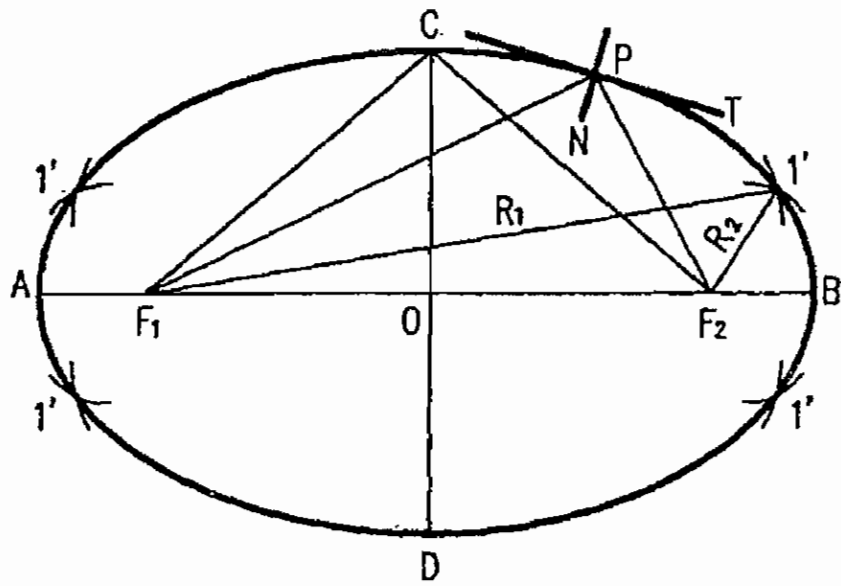

**ELLIPSE - CONCENTRIC CIRCLES METHOD**

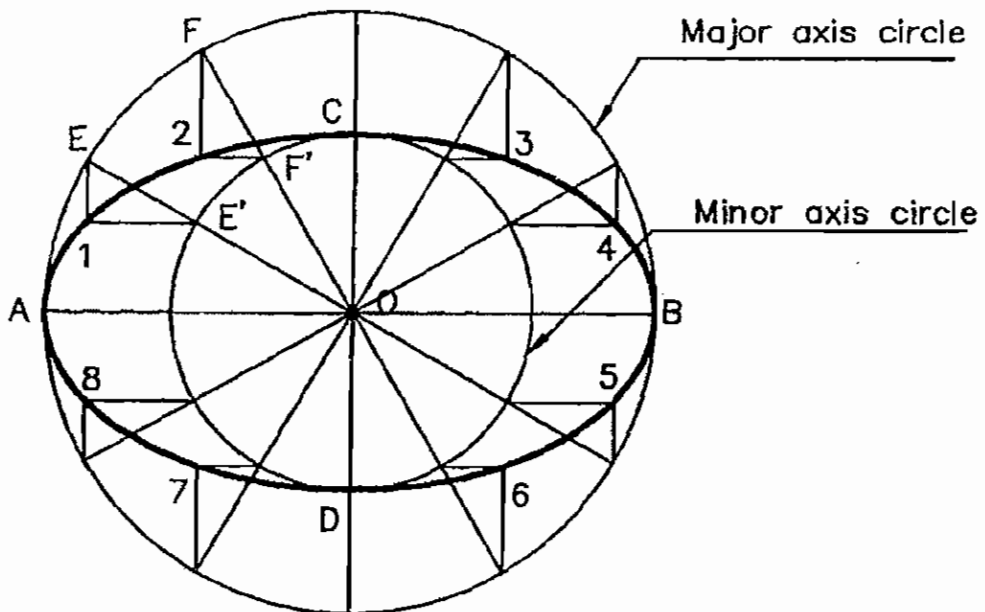

## PARABOLA - RECTANGLE METHOD

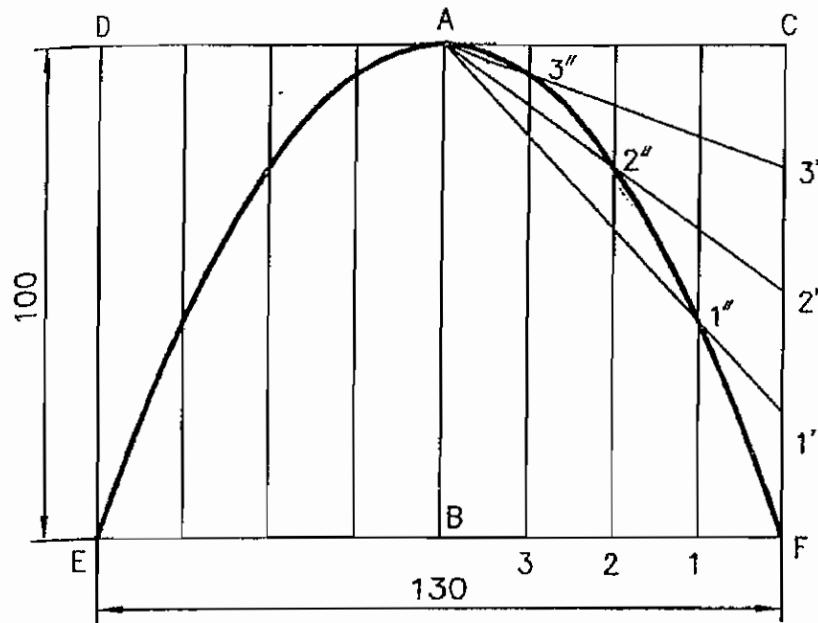

## PARABOLA - TANGENT METHOD

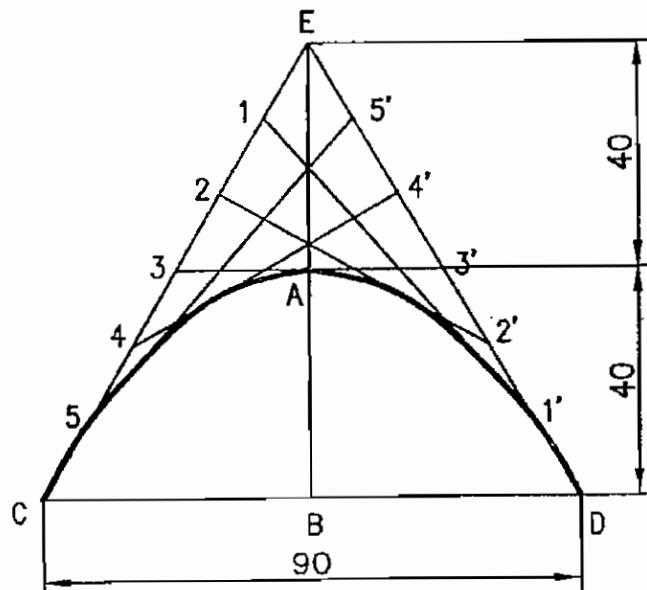

ALL DIMENSIONS ARE IN MILLIMETRES













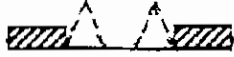

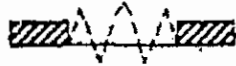

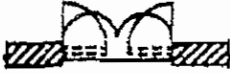

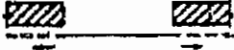









## 05. CONVENTIONAL SYMBOLS OF MATERIALS

MATERIAL		SYMBOL		CONVENTIONAL SIGNS		MATERIAL		SYMBOL	
EARTH		REINFORCED CEMENT CONCRETE		INDIAN TYPE W/C		SPECIAL BRICK		ROCK	
SAND		TIMBER IN CROSS SECTION		PEDESTAL TYPE URINALS		LEAD, ZINC		STEEL, COPPER, ALUMINIUM	
BRICK		TIMBER IN LONGITUDINAL SECTION		URINAL STALL		ASBESTOS, FELT, ETC.		PARTITION BLOCK	
STONE		GLASS		CEILING FAN		WATER PIPE LINE		PLASTER	
BRICK WORK IN ELEVATION		STAIR CASE		PLAIN KITCHEN SINK					
PLAIN CEMENT CONCRETE									

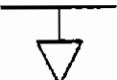
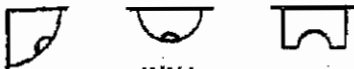



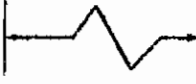
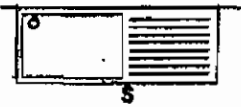









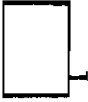

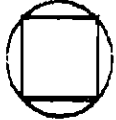

## 06. SYMBOLS FOR DOORS AND WINDOWS

<p>TOP HUNG WINDOW</p> 	<p>DOUBLE SWING DOOR</p>  <p>2 - LEAF</p>
<p>HORIZONTAL CENTRE HUNG</p> 	<p>FOLDING DOOR</p>  <p>SIDE HUNG</p>
<p>VERTICAL CENTRE HUNG</p> 	<p>FOLDING DOOR</p>  <p>CENTER HUNG</p>
<p>SIDE HUNG WINDOW IN ELEVATION</p>  <p>RH LH</p>	<p>FOLDING DOOR</p>  <p>2 - LEAF</p>
<p>SINGLE SWING DOOR</p>  <p>SINGLE LEAF</p>	<p>SLIDING DOOR</p> 
<p>SINGLE SWING DOOR</p>  <p>DOUBLE LEAF</p>	<p>ROLLING DOOR</p> 
<p>DOUBLE SWING DOOR</p>  <p>SINGLE LEAF</p>	<p>REVOLVING DOOR</p> 
<p><b>SYMBOLS FOR DOORS &amp; WINDOWS</b></p>	

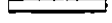
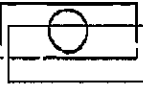
**07. SYMBOLS FOR SANITARY FITTINGS**

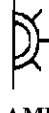
<p><b>BATH TUB</b></p> 	<p><b>DRINKING FOUNTAIN</b></p>  <p>WALL &amp; PEDESTAL TYPE</p>
<p><b>SHOWER STALL</b></p> 	<p><b>WATER METER</b></p>  <p>W.M</p>
<p><b>WATER CLOSET</b></p>  <p>EUROPEAN      INDIAN</p>	<p><b>FIRE EXTINGUISHER</b></p>  <p>F.E</p>
<p><b>UPINAL</b></p>  <p>CORNER      WALL HUNG      FLOOR</p>	<p><b>PUMP</b></p> 
<p><b>LAVATORY BASIN</b></p>  <p>WALL      PEDESTAL</p>	<p><b>WASHING MACHINE</b></p> 
<p><b>PLAIN KITCHEN SINK</b></p> 	<p><b>VENT OUTLET</b></p> 
<p><b>SINK WITH DRAINAGE BOARD</b></p> 	<p><b>RAIN WATER OUTLET</b></p>  <p>RWO</p>
<p align="center"><b>SYMBOLS FOR SANITARY FITTINGS</b></p>	

## 08. SYMBOLS FOR ELECTRICAL FITTINGS

<p><b>FUSE BOARD</b></p>  <p>MAIN</p>  <p>DISTR.</p>	<p><b>ALARM</b></p>  <p>BELL</p>  <p>BUZZER</p>
<p><b>MAIN SWITCH</b></p> 	<p><b>SWITCH</b></p>  <p>ONE WAY</p>  <p>TWO WAY</p>
<p><b>METER</b></p> 	<p><b>CEILING FAN</b></p> 
<p><b>LIGHT POINT</b></p>  <p>BRACKET</p>  <p>PENDANT</p>	<p><b>EXHAUST FAN</b></p> 
<p><b>LIGHT POINT</b></p>  <p>BULK HEAD</p>  <p>TUBE LIGHT</p>	<p><b>ELE. HEATER</b></p> 
<p><b>PIN SOCKET</b></p>  <p>5 AMPS</p>  <p>15 AMPS</p>	<p><b>TELEPHONE</b></p> 
<p><b>BELL PUSH</b></p> 	<p><b>EARTHING</b></p> 
<p align="center"><b>SYMBOLS FOR ELECTRICAL FITTINGS</b></p>	

09. ISOMETRIC VIEW & ORTHOGRAPHIC PROJECTIONS - MODEL - I

ISOMETRIC VIEW

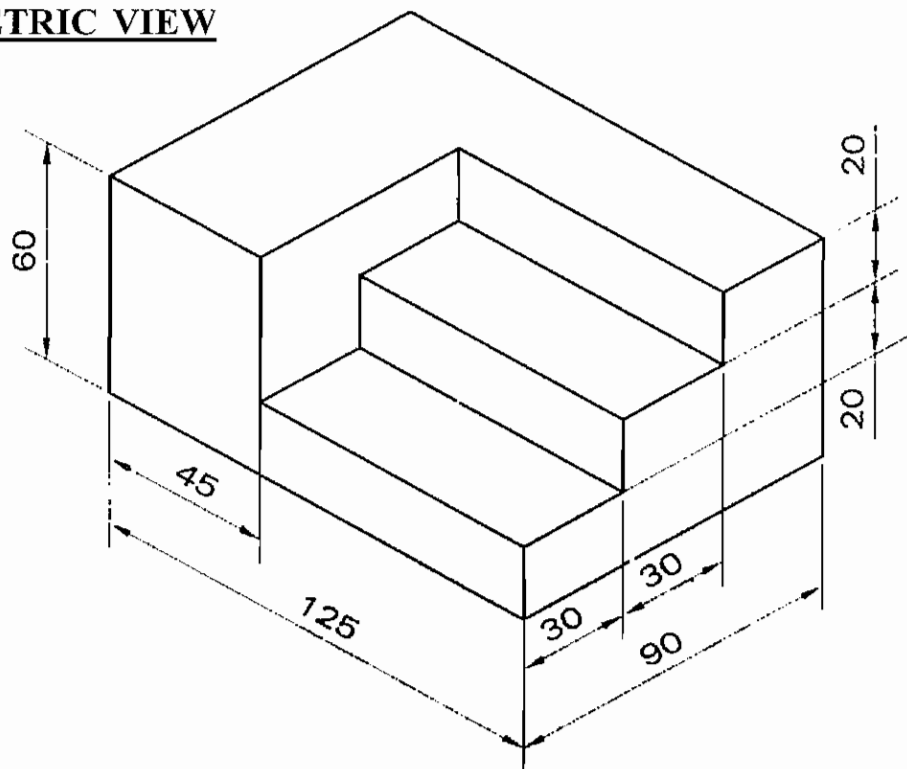

ISOMETRIC VIEW

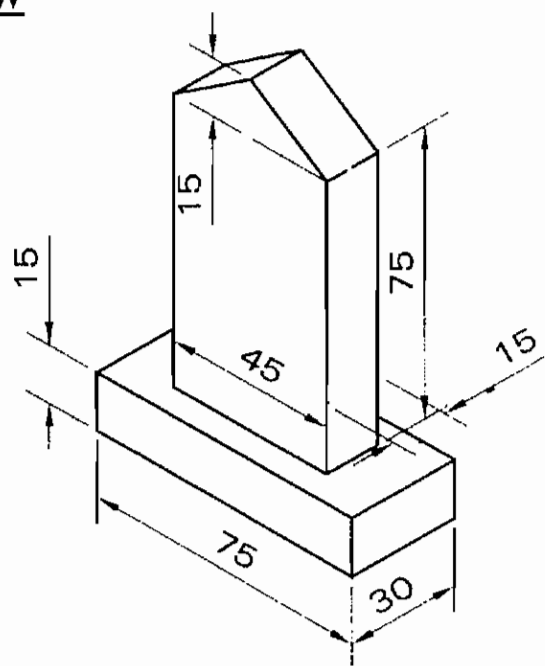

ALL DIMENSIONS ARE IN MILLIMETRES

10. ISOMETRIC VIEW & ORTHOGRAPHIC PROJECTIONS - MODEL - II

ISOMET

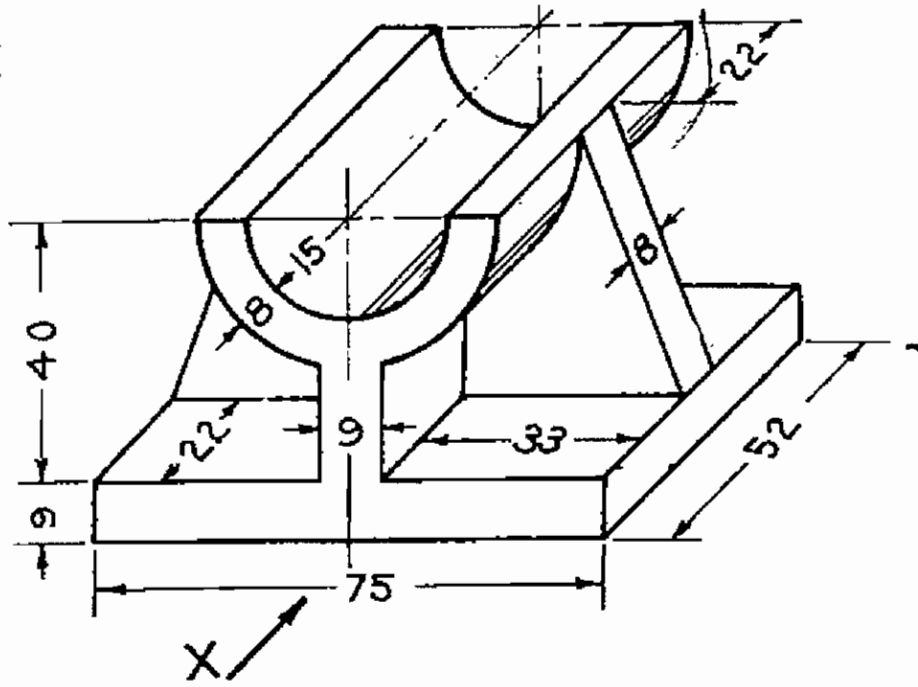

ISOMETRIC VIEW

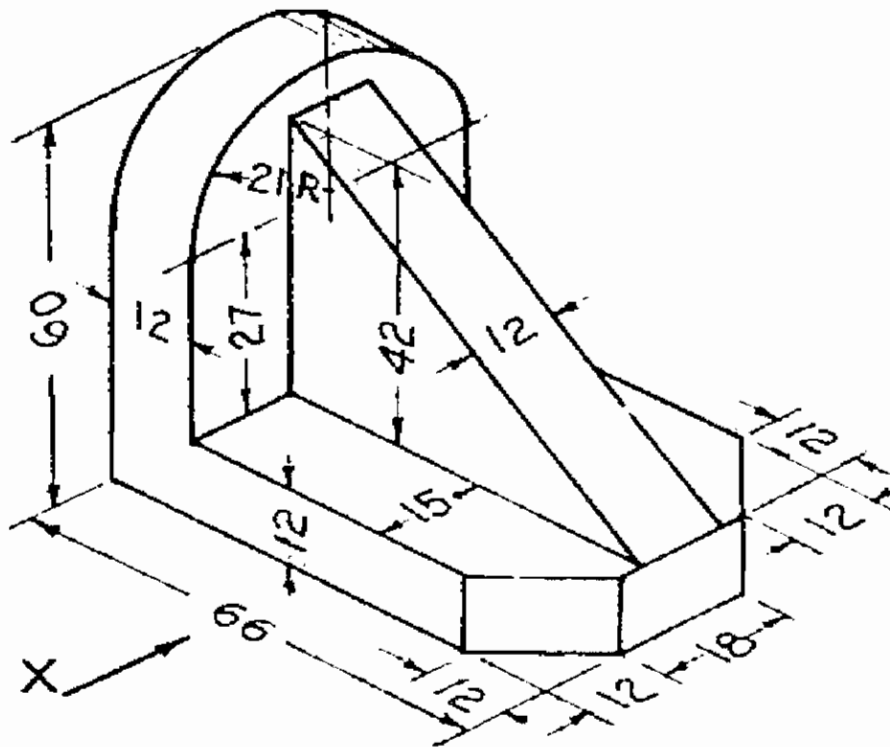

ALL DIMENSIONS ARE IN MILLIMETRES

11. BOND IN BRICK WORK – RIGHT ANGLED (ENGLISH BOND (OR) FLEMISH BOND)

ENGLISH BOND

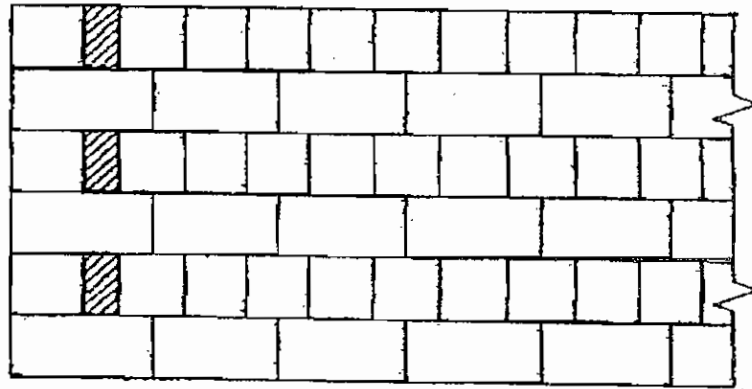

ELEVATION

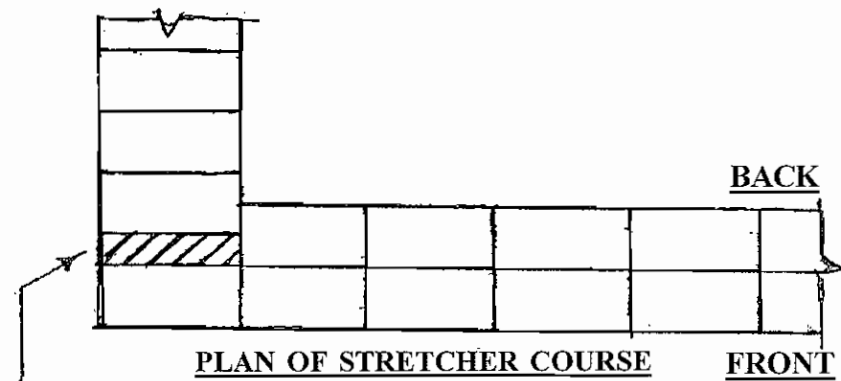

PLAN OF STRETCHER COURSE

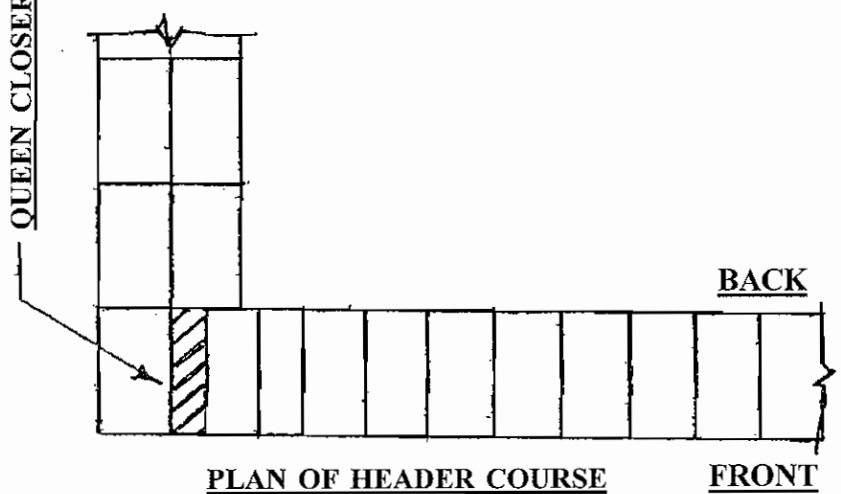

PLAN OF HEADER COURSE

ONE BRICK WALL - 20 CM



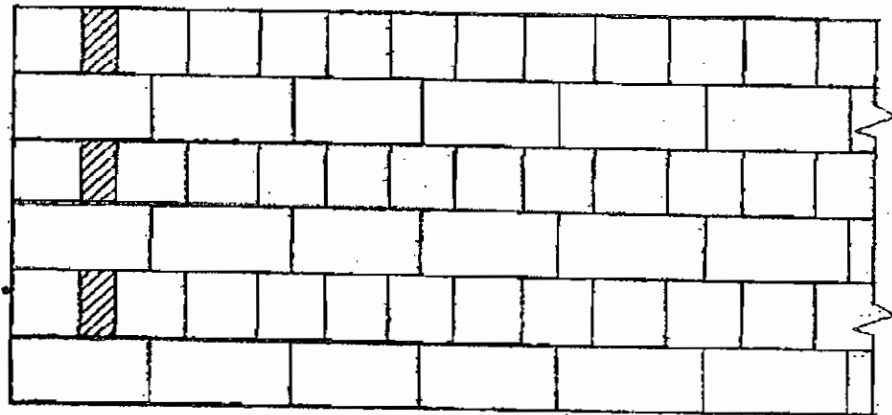

ELEVATION

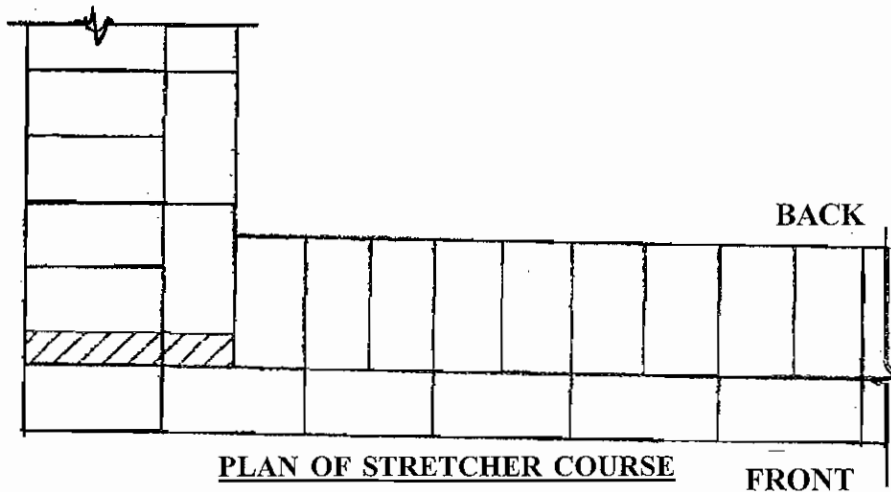

PLAN OF STRETCHER COURSE

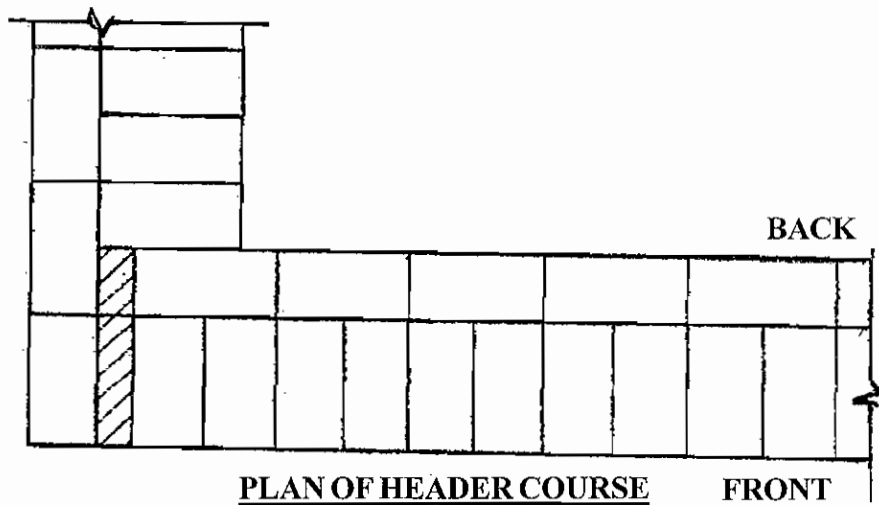

PLAN OF HEADER COURSE

**ONE AND HALF BRICK WALL - 30 CM.**

# FLEMISH BOND

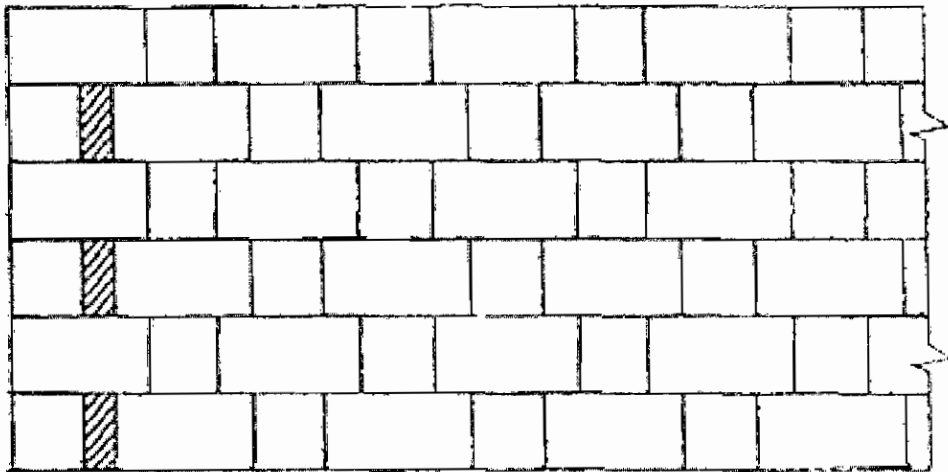

FRONT ELEVATION

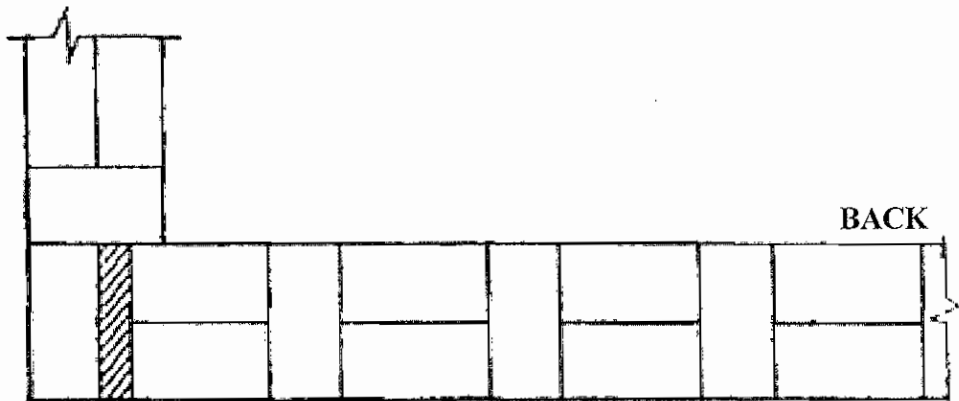

ONE BRICK WALL

BACK

FRONT

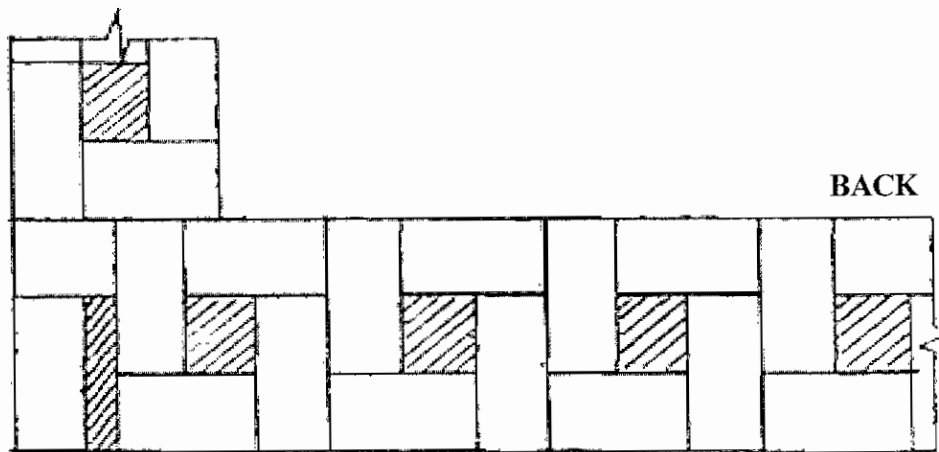

ONE & HALF BRICKS WALL

BACK

FRONT

PLAN - ODD COURSE

# FLEMISH BOND

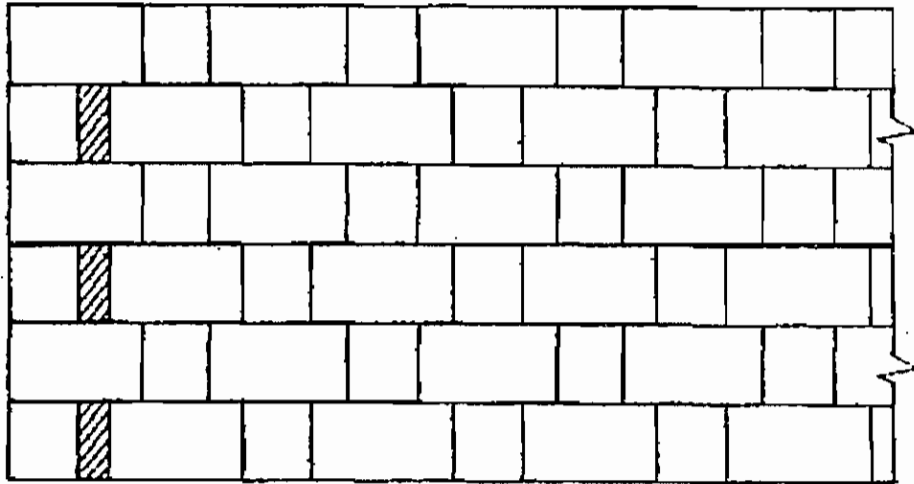

FRONT ELEVATION

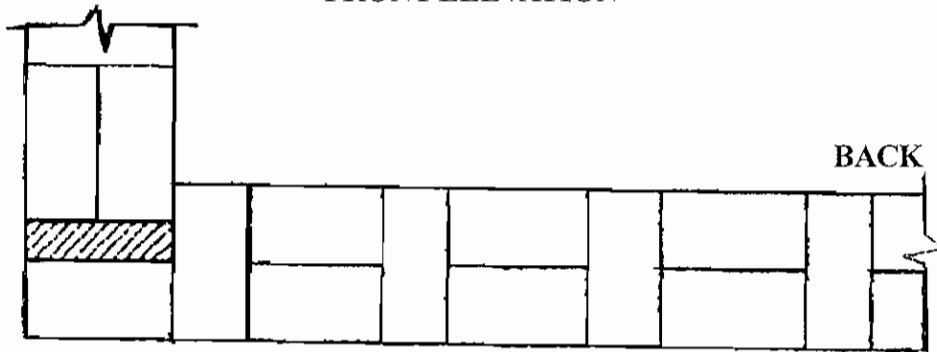

ONE BRICK WALL

FRONT

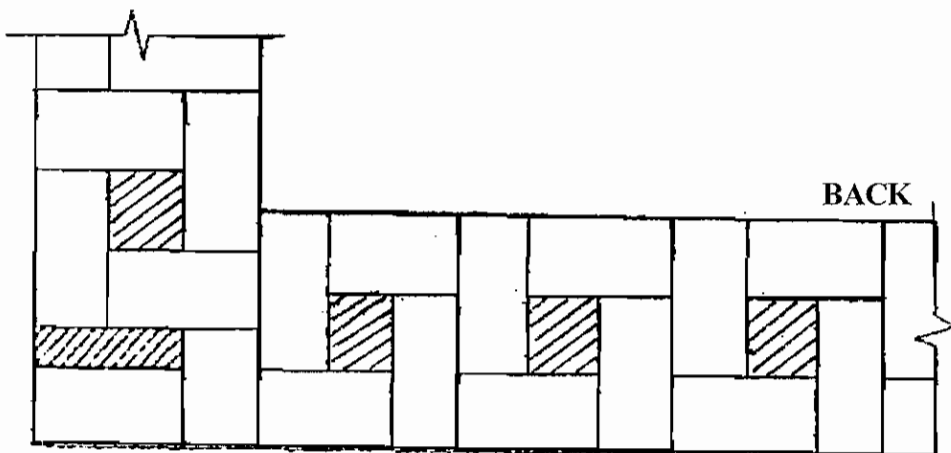

ONE & HALF BRICKS WALL

FRONT

## PLAN - EVEN COURSE

# FOUNDATION

## 12. SECTION OF FOUNDATION (TYPES OF FOOTINGS OF WALL AND FOUNDATION DETAILS FOR STEPS AND WALL)

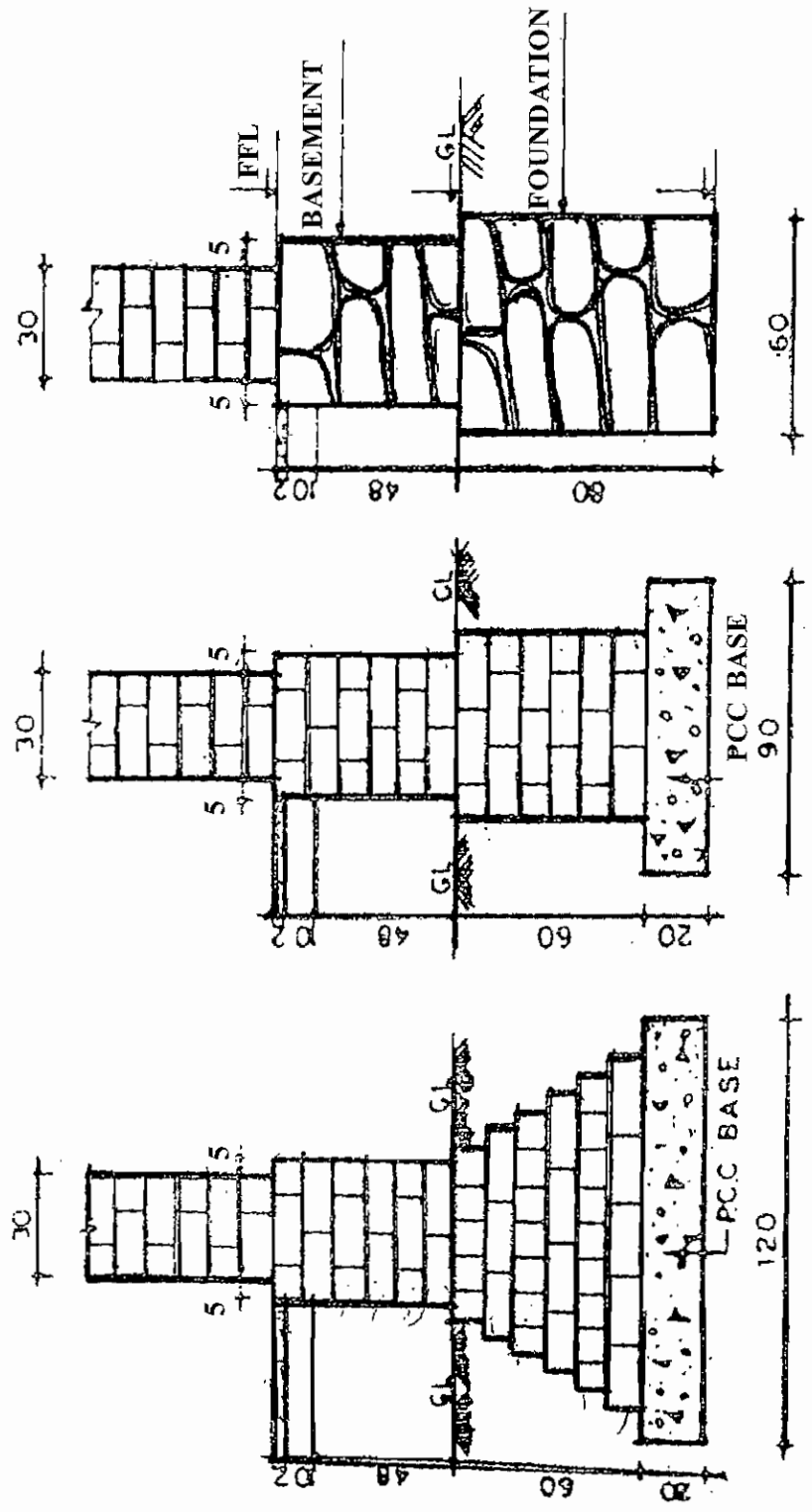

### TYPES OF FOOTINGS FOR WALLS

DIMENSIONS IN CENTI METRES

# FOUNDATION

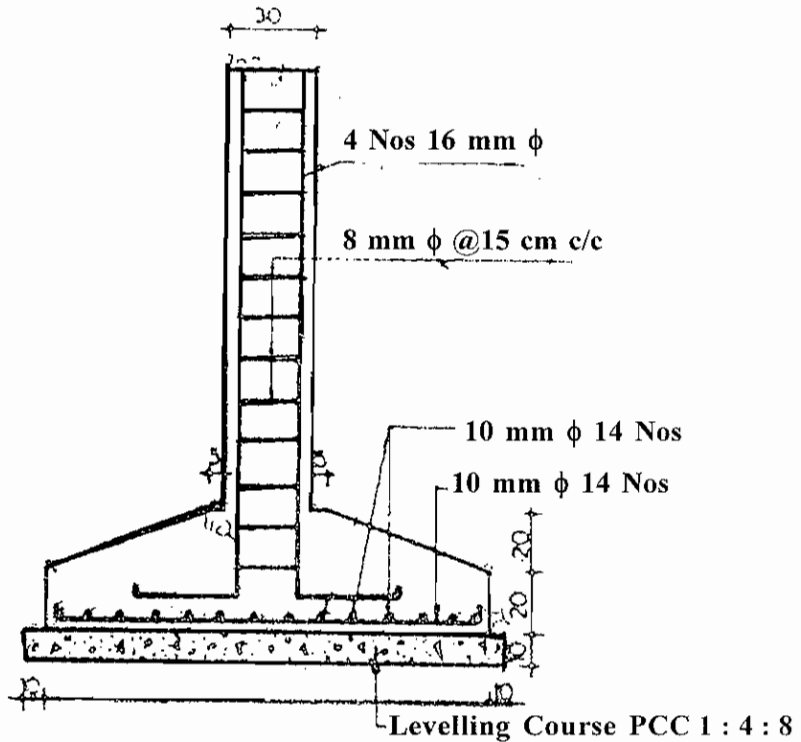

SECTION AA

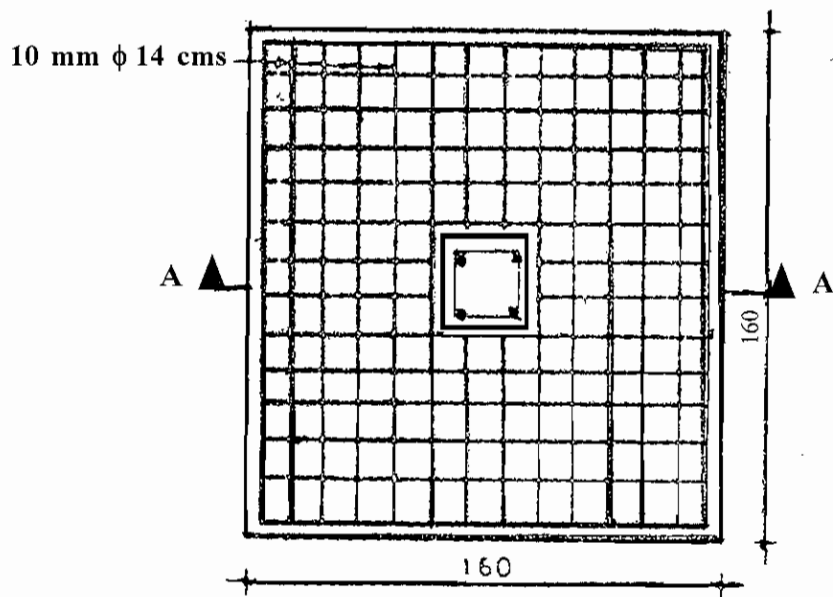

PLAN

SHOWING ARRANGEMENT OF REINFORCEMENT

## FOOTINGS FOR A RCC COLUMN

DIMENSIONS IN CENTIMETRES

# FOUNDATION AND STEPS

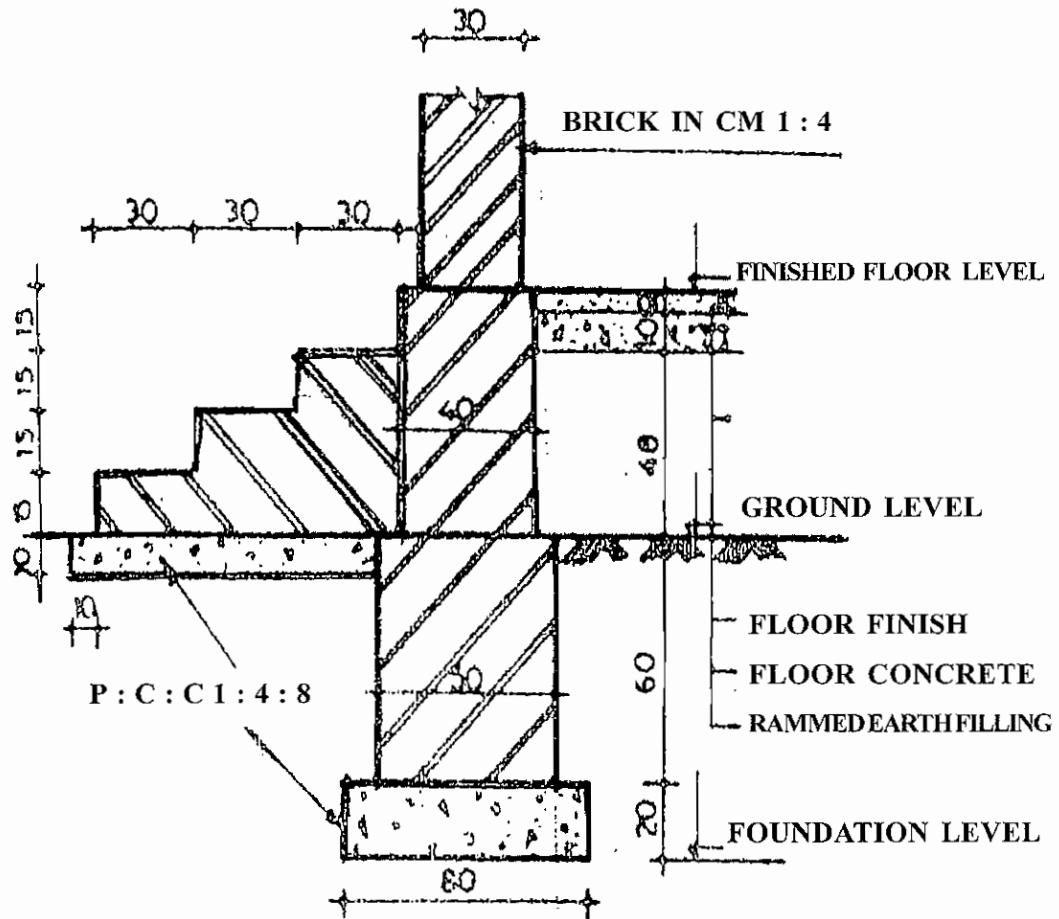

## FOUNDATION DETAILS FOR STEPS AND WALL

DIMENSIONS IN CENTI METRES

13. ARCHES (FLAT, SEMI CIRCULAR, ELLIPTICAL AND SEGMENTAL ARCH)

DEVELOPMENT OF ARCH

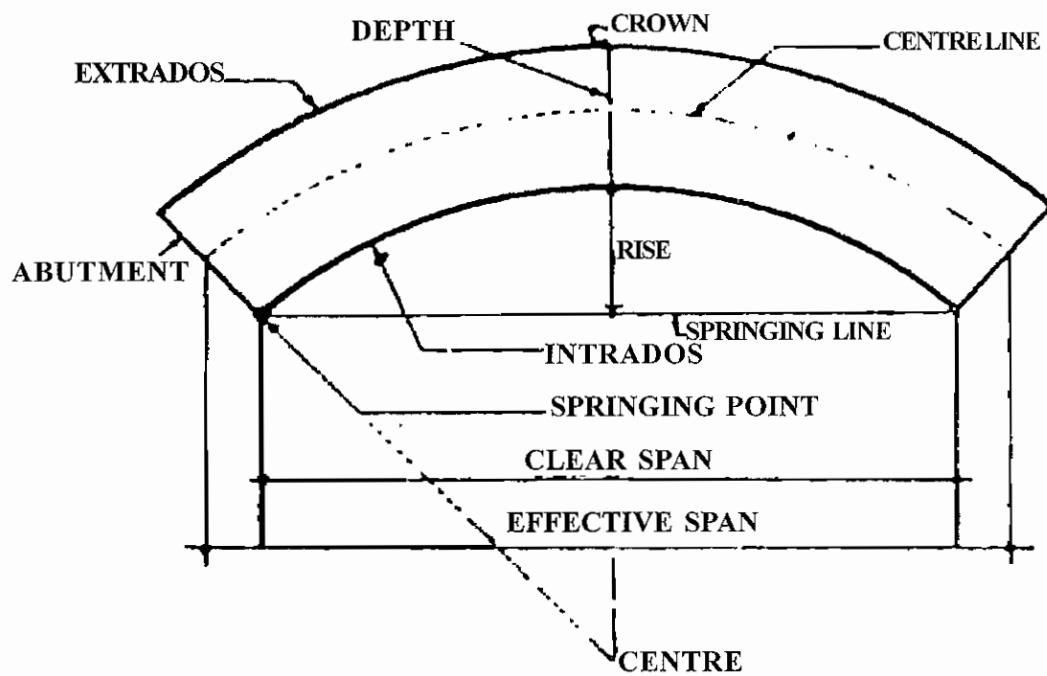

CIRCULAR SEGMENTAL ARCH

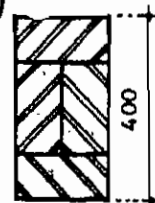
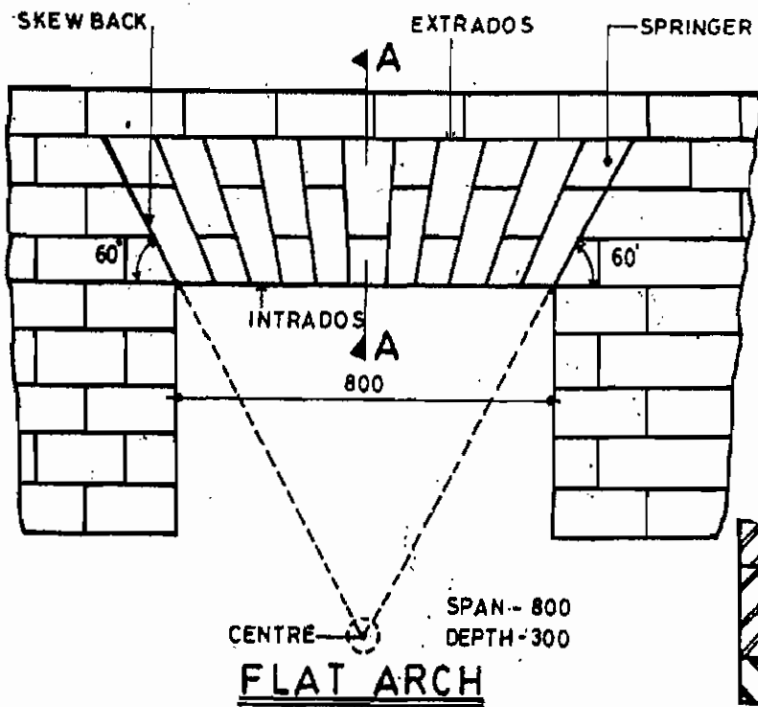

**SECTION ON AA**

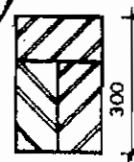
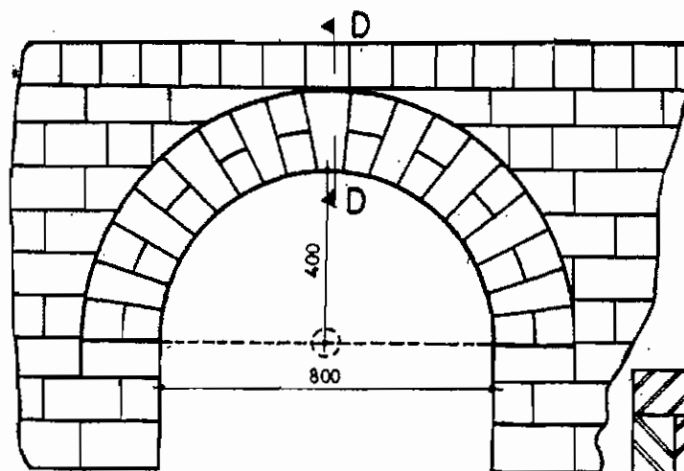

**SEMICIRCULAR ARCH**

**SECTION ON DD**



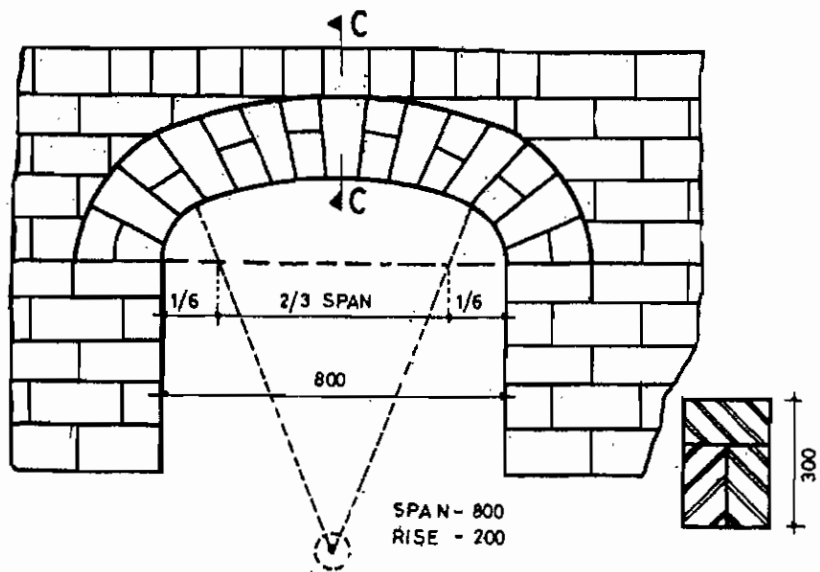

ELLIPTICAL ARCH  
(3-CENTRED)

SECTION ON CC

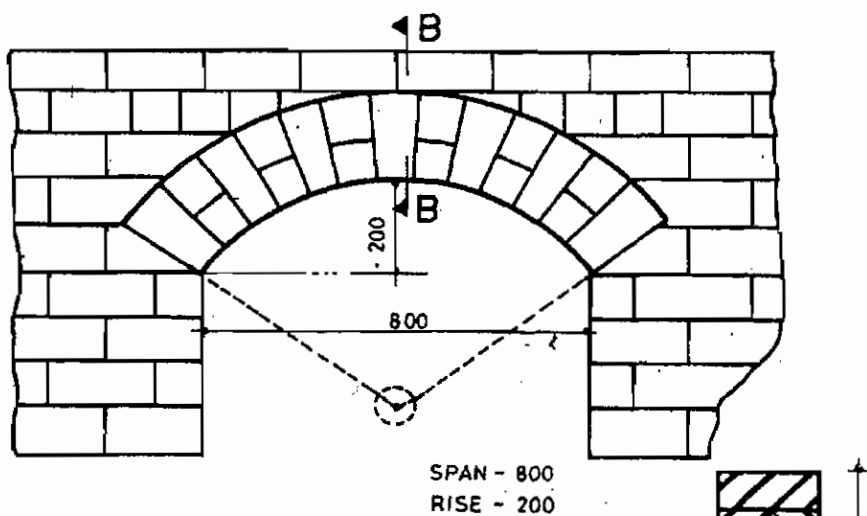

SEGMENTAL ARCH

SECTION ON BB

# 14. PANEL DOOR

## DEVELOPMENT OF DOOR

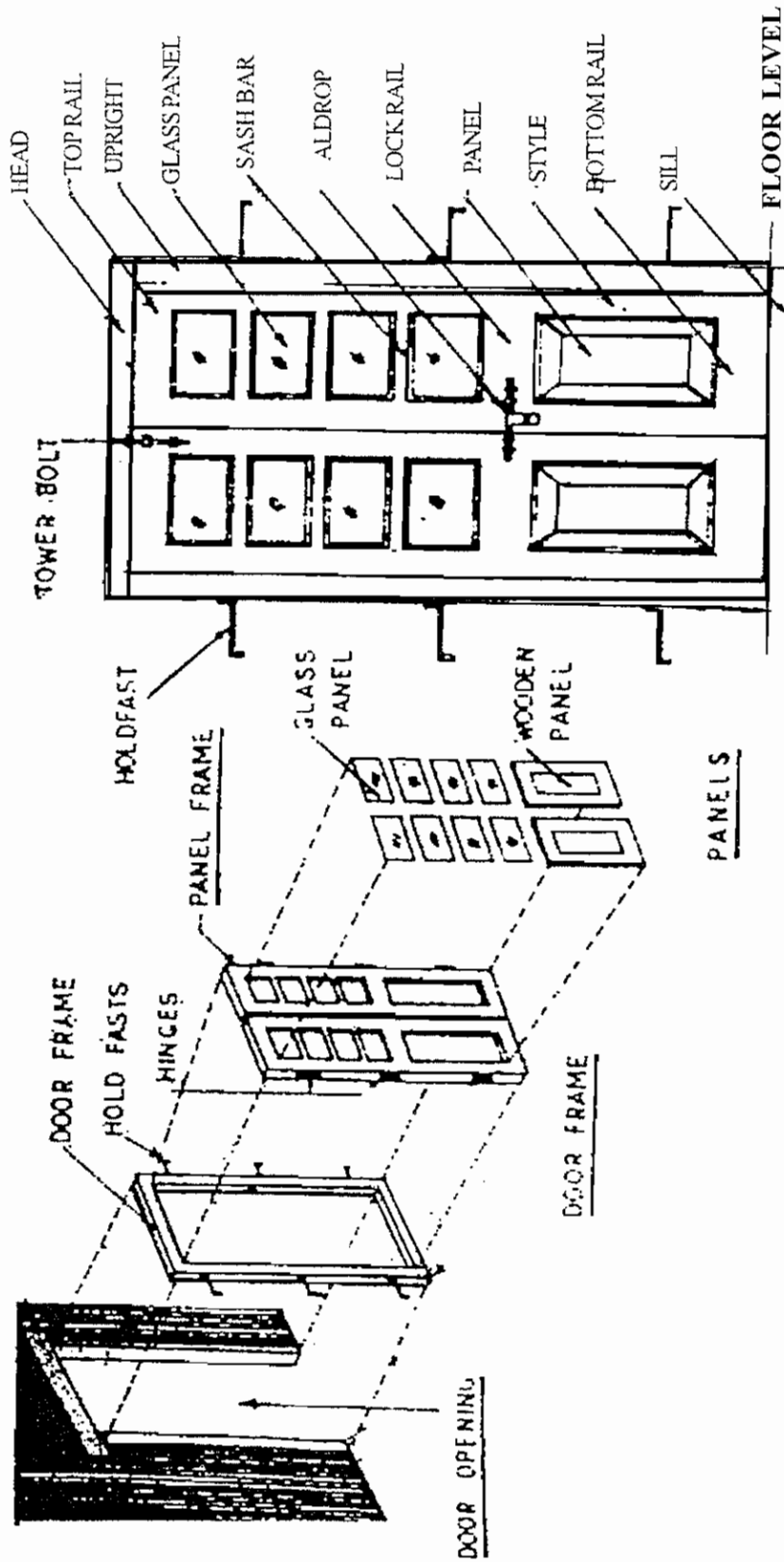

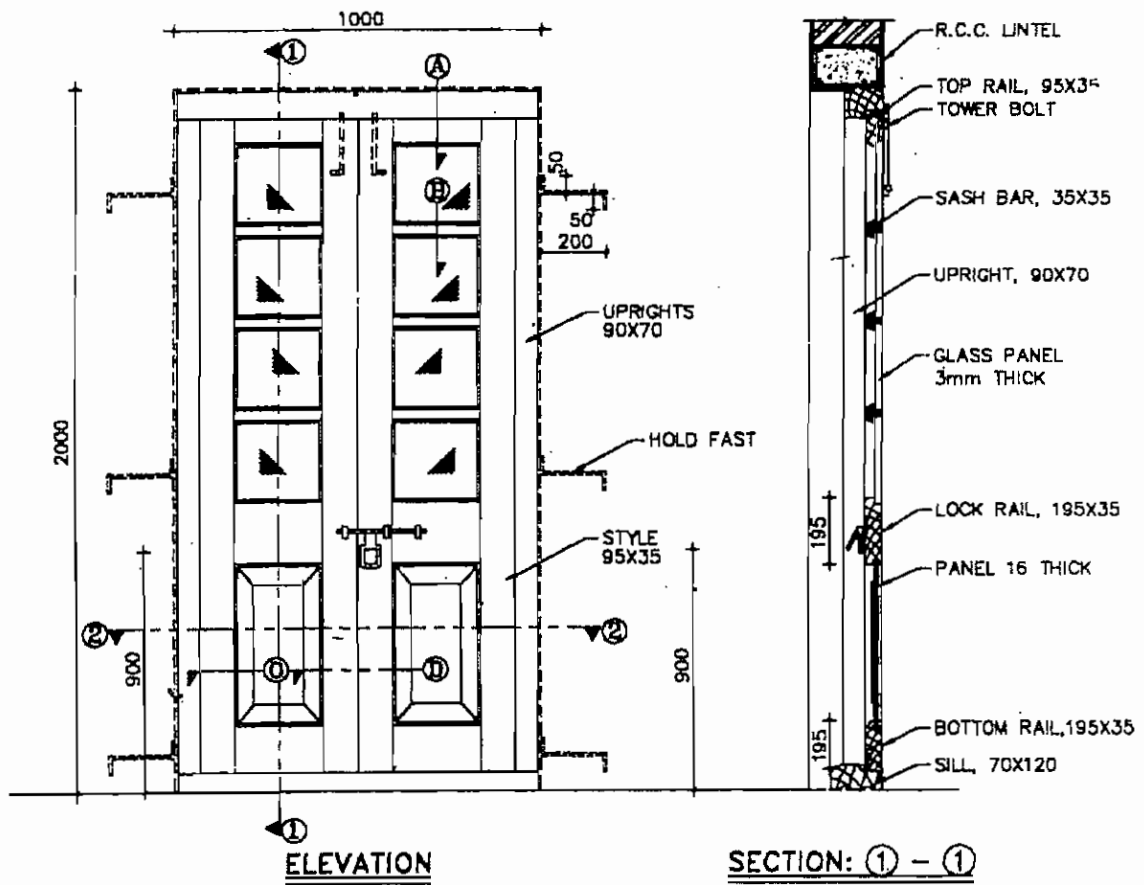

## PANEL DOOR

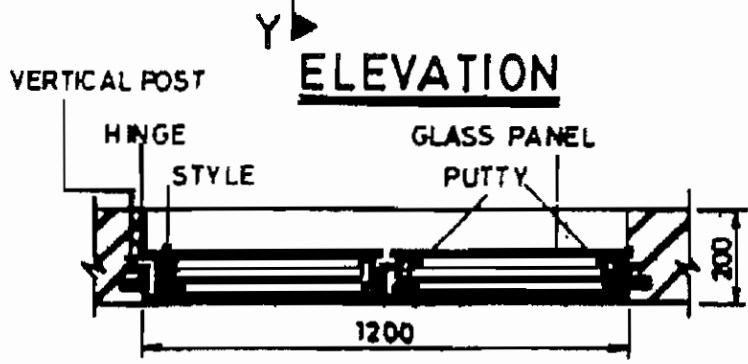
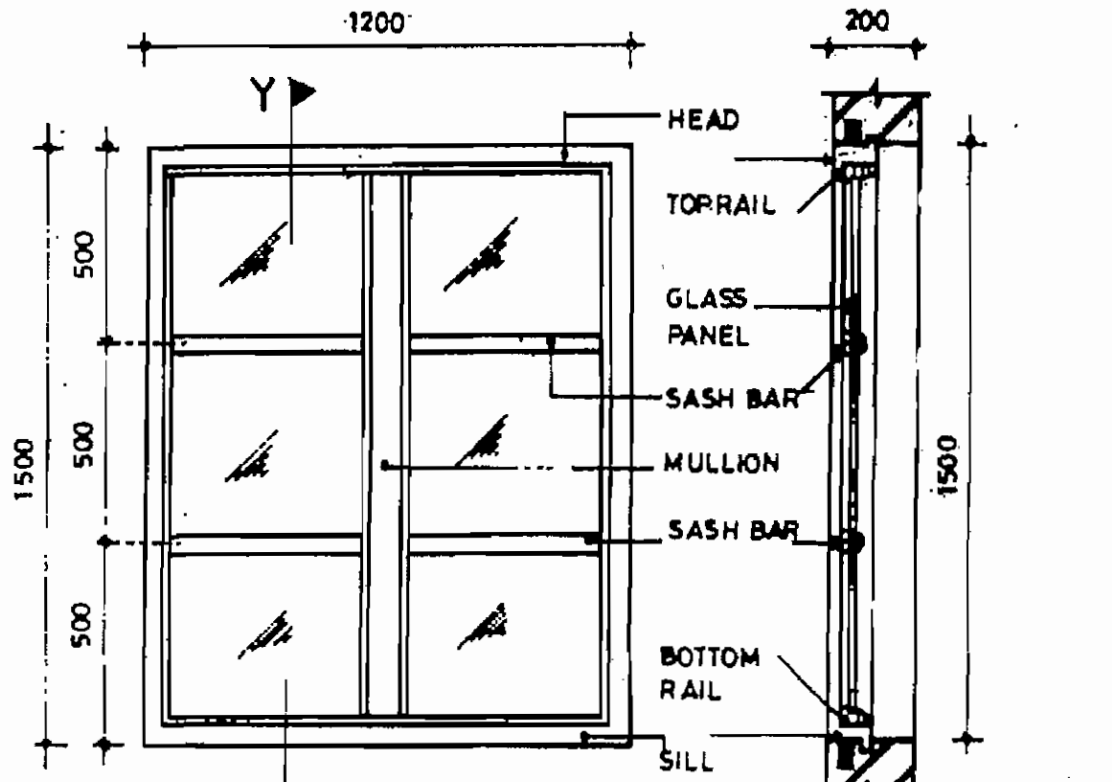

**ELEVATION**

**SECTION ON 'YY'**

**SECTIONAL PLAN**

**GLAZED WINDOW**

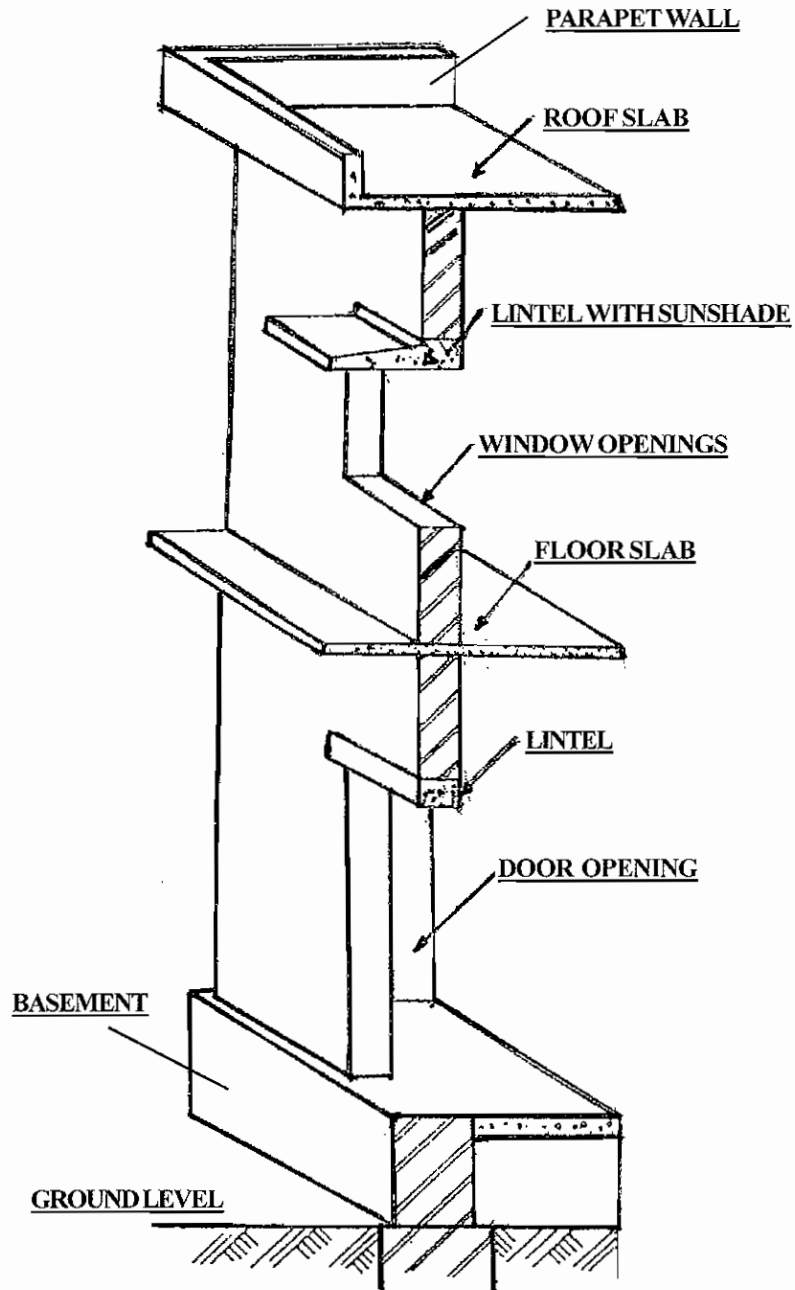

**WALL SECTION SHOWING LINTELS  
OVER WALL OPENINGS**

# **PRACTICAL II**

## **(LAB)**

## **PRACTICAL II**

### **FOR STUDENTS ATTENTION...**

1. Before coming to the laboratory discuss the experiment with friends and plan well by reading this hand book.
2. Write the required observation thoroughly in the observation note before coming to the laboratory.
3. Date, Experiment No, Aim, Appratus required, Equation, Procedure and Result should be written on the right side of the observation note / record note. Figure, tabular column, observation and calculation should be written on the left side.
4. After completing the experiment in the laboratory the noted observation should be shown to the teacher and get the signature.
5. Note the measurement (gram, cm, mm ..... ) in the same unit as measured. Final calculation should be only in SI units.

Note the result in SI Units.

## **01. DETERMINE THE NORMAL CONSISTENCY OF THE GIVEN CEMENT SAMPLE**

### **NORMAL CONSISTENCY TEST**

#### **Aim**

To find the normal consistency of the given sample of cement.

#### **Appratus and materials required**

1. Vicat's apparatus
2. 10mm dia plunger
3. Mould
4. Non porous plate
5. Weighing balance
6. Measuring jar and water
7. A Container
8. Trowel
9. Clock
10. Cement sample (400 grams)

#### **Procedure**

1. Take 400 grams of cement
2. Add 20% of water ( $\frac{20}{100} \times 400 = 80$  ml) to the cement and prepare the paste.
3. Fix the plunger with the vicat's apparatus and adjust the pointer to point out zero when the plunger is placed above the non porous plate.
4. Fill the prepared paste in the mould and place it above the plate.
5. Bring the plunger just above the paste and allow it to penetrate the paste freely.
6. Note down whether the pointer points towards 5mm to 7mm on the vicat's scale.
7. If not, repeat the above steps by increasing the percentage of water.
8. Note the percentage of water for which the pointer points 5mm to 7mm on the scale. That is the percentage of normal consistency for that cement sample.



**Table**

S.No.	Percentage of water	Amount of water added	Pointers Reading
1			
2			
3			
4			
5			

**Result**

The Normal Consistency for the given cement sample is \_\_\_\_\_%.

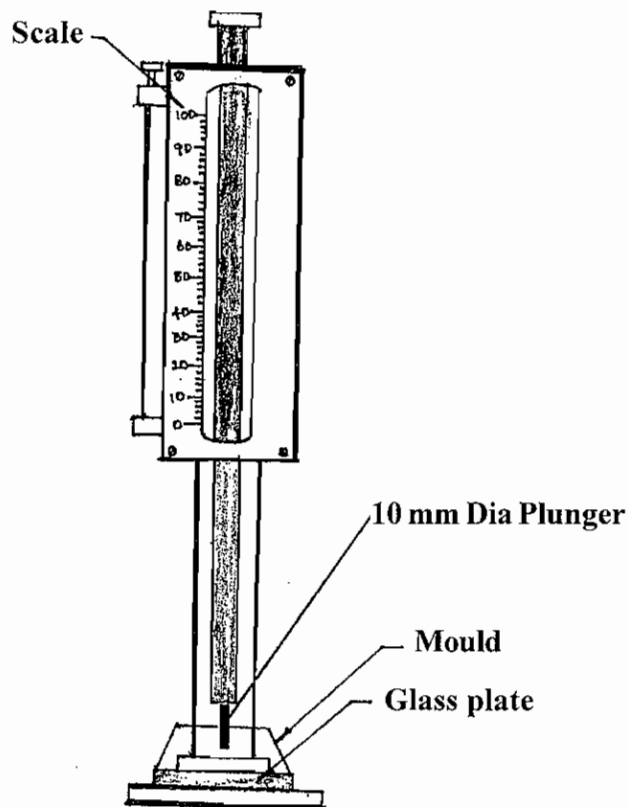

**VICAT'S APPARATUS**

## 02. DETERMINE THE INITIAL SETTING TIME OF THE GIVEN CEMENT SAMPLE

### INITIAL SETTING TIME TEST

#### Aim

To find out the initial setting time of given sample of cement

#### Apparatus and Materials required

1. Vicat's apparatus
2. Needle (1 sq mm in c/s)
3. Mould
4. Non porous plate
5. Weighing balance
6. Measuring jar and water

#### Procedure

1. Take 400 gms of cement. Add 0.85 times of normal consistency of water. Note the time of adding water.
2. Fix the initial setting time needle with the apparatus and adjust the pointer to point zero when the needle is placed above the plate.
3. Fill the prepared paste in the mould and place it above the plate.
4. Bring the square needle just above the paste and allow it to penetrate the paste. Note the measurement on the scale. In the beginning it penetrates completely. It is then taken out and dropped at a new place. The procedure is repeated until the pointer 5mm to 7mm in the vicat's scale.
5. Note the time. Initial setting time of cement is the time from the addition of water, till the penetration is between 5mm – 7mm from the bottom.

#### Observations

Wt. of cement sample = 400 grams  
Percentage of water added = 0.85 x Normal consistency value

S.No.	Time (in minutes)	Pointer's reading (In mm)
1		
2		
3		
4		
5		

**Result**

The initial setting time of the given cement sample is \_\_\_\_\_ minutes.

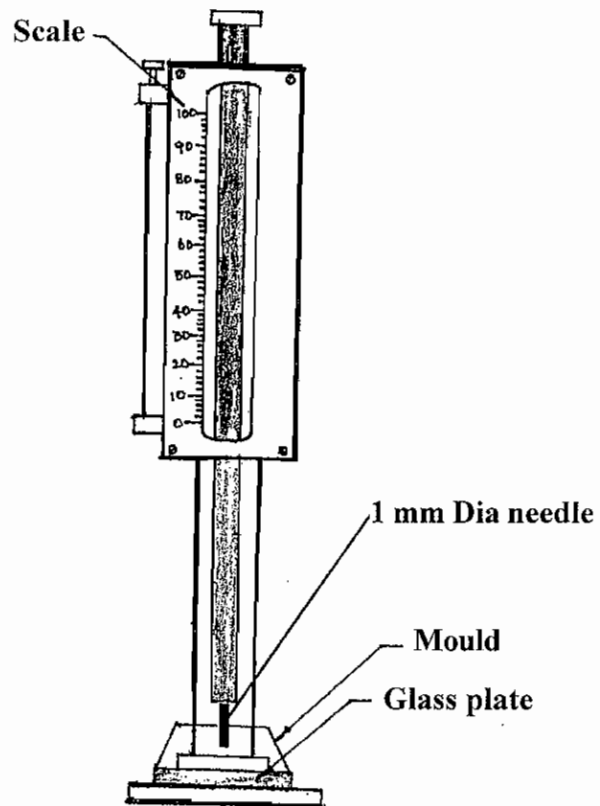

**VICAT'S APPARATUS**

### 03. DETERMINE THE FINENESS VALUE OF THE GIVEN CEMENT SAMPLE

#### FINENESS TEST

##### Aim

To find out the fineness of the given sample of cement.

##### Materials and apparatus required

1. I.S. sieve No. 9 (90 micron)
2. Weighing balance
3. Trowel
4. Cement sample (100 gms)

##### Procedure

1. 100 gms of cement is taken using weighing balance. Let it be 'W<sub>1</sub>' gms.
2. The cement is placed in the I.S. 90 micron sieve and the sieve is shaken for about 15 minutes.
3. The residue in the sieve is taken and weighed using weighing balance. Let it be 'W<sub>2</sub>' gms.
4. The percentage of residue is worked out by using the formula

$$\frac{W_1 - W_2}{W_1} \times 100$$

##### Note

The residue should not exceed 10% for ordinary Portland cement and 5% for rapid hardening cement.

##### Observations

Wt of cement sample taken (W<sub>1</sub>) = \_\_\_\_\_  
Wt of residue in the sieve (W<sub>2</sub>) = \_\_\_\_\_  
Fineness value =  $\frac{W_1 - W_2}{W_1} \times 100$

##### Result

The fineness value of the given cement sample is \_\_\_\_\_%.

## 04. DETERMINE THE VOID RATIO OF THE GIVEN SAND SAMPLE

### VOID RATIO

#### Aim

To determine the voids ratio in the given sand sample.

#### Definition

Void ratio represent the ratio between the volume of voids and the total volume including solid matters and voids.

$$\text{Voids ratio 'e'} = \frac{\text{Volume of voids}}{\text{Volume of solids}}$$

#### Apparatus and materials required

1. Spring balance
2. Bucket
3. Sand
4. Water
5. 16mm dia, 600mm length tamping rod

#### Procedure

1. Take a clean dry bucket and weigh it ( $W_1$  grams)
2. Take about 1/3<sup>rd</sup> bucket of clean sand and tamping the sand 25 times. Do the same against two times fill the bucket.
3. Weigh the bucket with sand ( $W_2$  grams)
4. Take bucket with sand and fill it with water and weigh it. ( $W_3$  grams)
5. Empty the bucket fill it with water and weigh it. ( $W_4$  grams)

#### Observation

- |  |                |   |
|--|----------------|---|
| 1. Weight of the empty bucket            | ( $W_1$ grams) | = |
| 2. Weight of the (bucket + sand)         | ( $W_2$ grams) | = |
| 3. Weight of the (bucket + sand + water) | ( $W_3$ grams) | = |
| 4. Weight of the (bucket + water)        | ( $W_4$ grams) | = |

$$\text{Voids ratio 'e'} = \frac{W_3 - W_2}{(W_4 - W_1) - (W_3 - W_2)}$$

**Result**

Voids of the given sand sample is = \_\_\_\_\_

**Soil Phase Diagram**

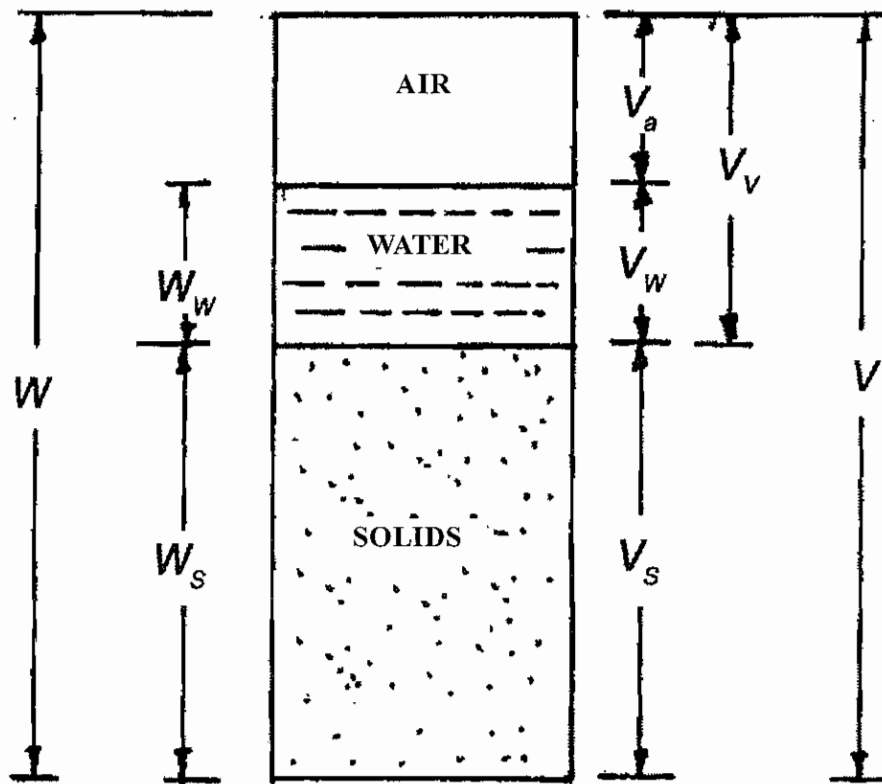

**Soil Phase Diagram**

## 05. DETERMINE THE POROSITY OF THE GIVEN SAND SAMPLE

### POROSITY

#### Aim

To determine the Porosity in the given sand sample.

#### Definition

Porosity of the given sand sample is ratio of the volume of voids to the total volume of given sand mass. It has no unit.

$$\text{Porosity 'n'} = \frac{\text{Volume of voids}}{\text{Total Volume of sand}}$$

#### Apparatus and materials required

1. Spring balance
2. Bucket
3. Sand
4. Water
5. 16mm dia, 600mm length tamping rod

#### Procedure

1. Take a clean dry bucket and weigh it ( $W_1$  grams).
2. Take about  $1/3^{\text{rd}}$  bucket of clean sand and tamping the sand 25 times. Repeat the something by filling the bucket  $2/3$  &  $3/3$  with clean sand.
3. Weighing the bucket with sand ( $W_2$  grams)
4. Take bucket with sand and fill it with water and weigh it. ( $W_3$  grams)
5. Now empty the bucket fill it with water and weigh it. ( $W_4$  grams)

#### Observation

1. Weight of the empty bucket ( $W_1$  grams) =
2. Weight of the (bucket + sand) ( $W_2$  grams) =
3. Weight of the (bucket + sand + water) ( $W_3$  grams) =
4. Weight of the (bucket + water) ( $W_4$  grams) =

$$\text{Porosity 'n'} = \frac{(W_3 - W_2)}{(W_4 - W_1)} \times 100$$

**Result**

Porosity of the given sand sample is = \_\_\_\_\_.

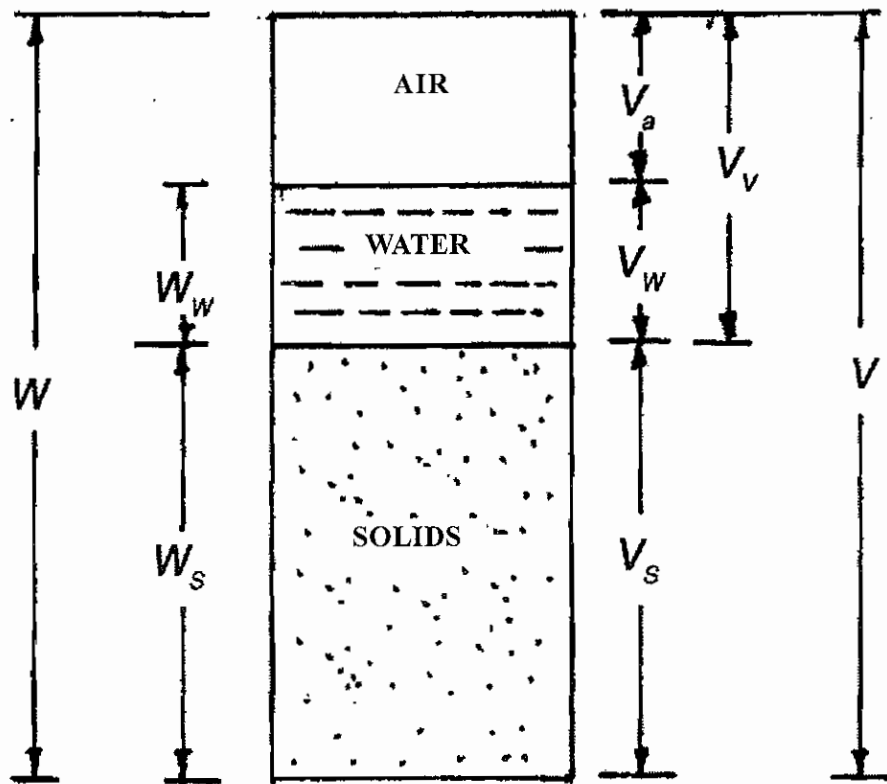

**Soil Phase Diagram**



## 06. DETERMINE THE BULK DENSITY OF THE GIVEN SAND SAMPLE.

### BULK DENSITY

#### Aim

To determine the Bulk density of the given sand sample.

#### Definition

Bulk density of the given sand sample is ratio between the weight of sand and its volume.  
(Unit = gram / cc)

$$\text{Bulk Density 'Y'} = \frac{\text{Weight of sand}}{\text{Volume of sand}}$$

#### Apparatus and materials required

1. Spring balance
2. Bucket
3. Sand
4. Water
5. 16mm dia, 600mm length tamping rod

#### Procedure

1. Take a clean dry bucket and weigh it ( $W_1$  grams).
2. Take about 1/3<sup>rd</sup> bucket of clean sand and tamping the sand 25 times. Do the same against two times fill the bucket.
3. Weighing the bucket with sand ( $W_2$  grams)
4. Take the bucket with 1/3 rd of clean sand and tamping the sand 25 times. Repeat the something by filling the bucket 2/3 & 3/3 with clean sand.
5. Now empty the bucket fill it with water and weigh it. ( $W_4$  grams)

#### Observation

- |  |                |   |
|--|----------------|---|
| 1. Weight of the empty bucket            | ( $W_1$ grams) | = |
| 2. Weight of the (bucket + sand)         | ( $W_2$ grams) | = |
| 3. Weight of the (bucket + sand + water) | ( $W_3$ grams) | = |
| 4. Weight of the (bucket + water)        | ( $W_4$ grams) | = |

Bulk density 'Y' = 
$$\frac{W_2 - W_1}{W_4 - W_1}$$

**Result**

Bulk density of the given sand sample is = \_\_\_\_\_.

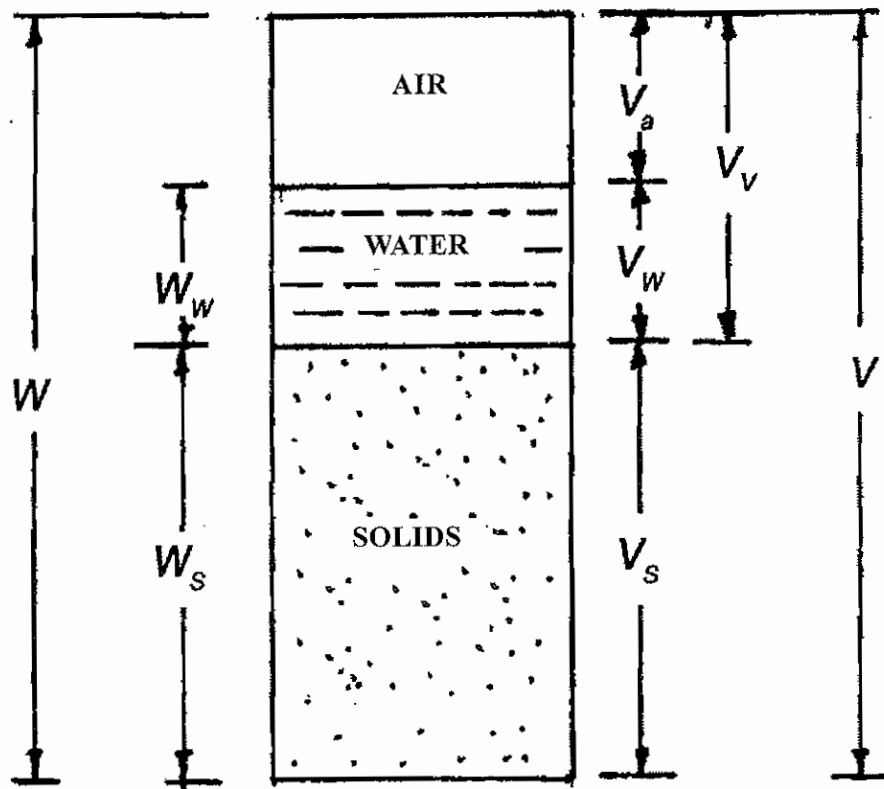

**Soil Phase Diagram**

## 07. WATER ABSORPTION TEST ON COARSE AGGREGATE

### WATER ABSORPTION - COARSE AGGREGATE

#### Aim

To determine the percentage of water absorption of given sample of coarse aggregate.

#### General Introduction

Water absorption test is one of the tests to determine the quality of coarse aggregate. It gives an idea of strength of coarse aggregate.

#### Apparatus and Materials required

1. Coarse aggregate sample
2. Weighing balance
3. Container with full of water

#### Procedure

1. Clean the test sample and weigh it as 'W<sub>1</sub>' gm.
2. It is immersed in clean water for about 72 hours.
3. Then it is removed and wiped out if any traces of water with a damp cloth.
4. It is the weighed in a weighing balance. Let it be 'W<sub>2</sub>' gm.

The percentage of water absorption is calculated using the formula  $\frac{W_2 - W_1}{W_1} \times 100$

#### TABULATION

Sl.No.	Dry weight of specimen W <sub>1</sub>	Weight of saturated specimen W <sub>2</sub>	Percentage of water absorption $\frac{W_2 - W_1}{W_1} \times 100$
Sample 1			
Sample 2			
Sample 3			

#### Note

Aggregates which absorbs not more than 0.6 percentage of water is suitable for road works.

#### Result

The percentage of water absorption for the given sample of coarse aggregate is \_\_\_\_\_%

## 08. WATER ABSORPTION TEST ON BRICK.

### Aim

To find out the percentage of water absorption for the given brick.

### General Information

This test is conducted to determine the quality of Bricks.

### Materials and Apparatus required

1. Bricks
2. Balance with weight
3. Tub with water

### Procedure

1. The given brick is cleaned and weighed by using the weighing balance. Let it be  $W_1$  gms.
2. It is then immersed in water in the tub for nearly 16 hours.
3. Now the brick is taken out from the tub and all the water on the surface of the brick is wiped off.
4. Now the wet brick is weighed by using the weighing balance. Let it be  $W_2$  gms.

The percentage of water absorption by the brick is calculated by using the formula

$$\frac{W_2 - W_1}{W_1} \times 100$$

Sl.No.	Dry weight of specimen $W_1$	Weight of saturated specimen $W_2$	Percentage of water absorption $\frac{W_2 - W_1}{W_1} \times 100$
Sample 1			
Sample 2			
Sample 3			

### Notes

The I class bricks may absorb water less than 20 percentage and the II class bricks may absorb water upto 22 percentage by weight.

### Result

The percentage of water absorption for the given brick sample is \_\_\_\_\_ %

## 09. SETTING OUT WORK FOR A SINGLE ROOM BUILDING FOR FOUNDATION.

### SETTING OUT BUILDINGS

#### Aim

To set out at the site, the intended lines of the foundation of a building.

#### Materials required

1. Measuring tape
2. Trisquare
3. Bundle of string
4. Hammer
5. Pegs
6. Lime Powder

#### Procedure

1. All the vegetations in the construction site are removed and levelled.
2. Study thoroughly the plan of the building. For example, take the inner measurements as 4.80 x 3.30 m
3. Prepare a centre line sketch.
4. The wall thickness of the building is 0.20m, so the centre to centre distance of the room is 5.00 x 3.50 m
5. Mark a straight line 'AB' (i.e. 5.00 m) and extend the both ends of the line and name it as 1 and 2. Tie a string tightly in it.
6. Set out a perpendicular line from 'B'. Mark the length of 'BC' (i.e. 3.50m). Extend the ends and name it as 3 and 4. Tie a string in it also.
7. Set out a perpendicular line 'CD' from 'C' (i.e. 5.00 m) and tie a string in the extended ends 5 and 6.
8. Like wise mark 'DA' and tie a string in it. Now check the diagonal of the string bounded rectangle 'ABCD.'
9. Mark the half of the width of the foundation on either side of the centre line and indicate it with Lime powder. Thus foundation trench is marked.

#### Checking

The diagonals 'AC' and 'BD' should be checked for the correctness. ( $AC = BD$ ).

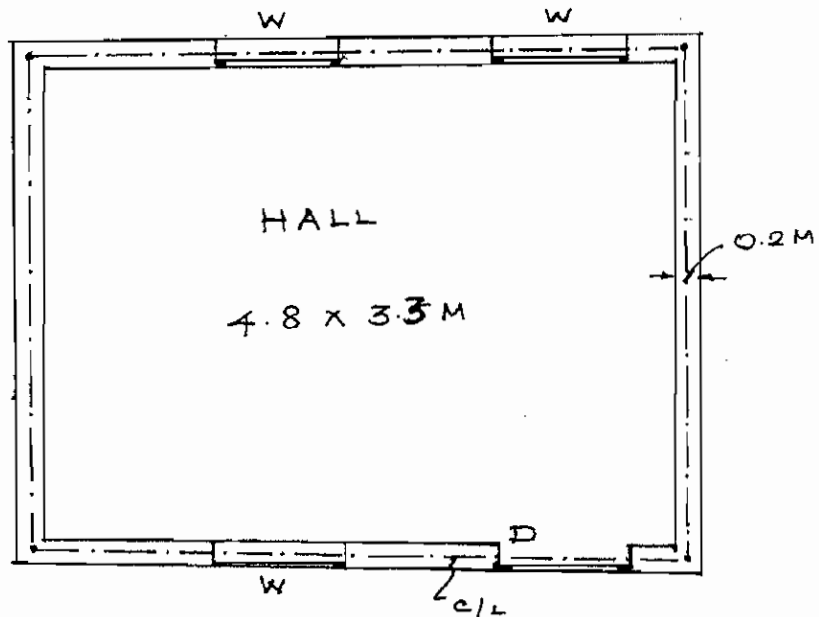

PLAN

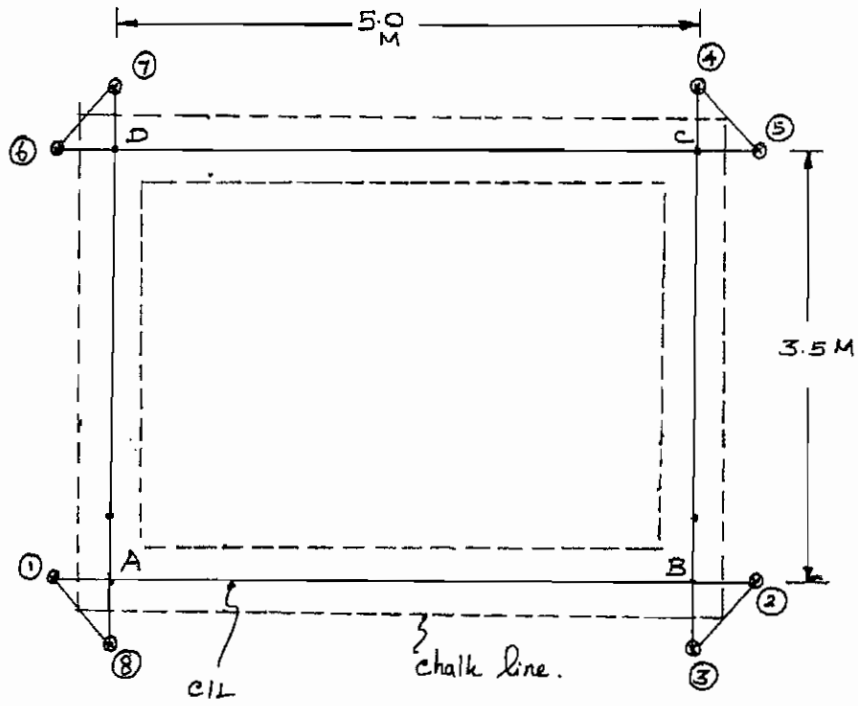

## **10. CONSTRUCT A BRICK MASONRY IN ENGLISH BOND FOR A ONE BRICK WALL.**

### **ARRANGEMENT OF BRICKS BY ENGLISH BOND**

#### **Aim**

To know the arrangement of bricks for 200mm walls at right angled conner in English bond.

#### **Tools required**

1. Bricks
2. Mortar
3. Trowel
4. Straight edge
5. Plumb bob
6. Spirit level
7. Trisquare

#### **Procedure**

##### **Featues of English Bond**

- i. It consists of headers and stretchers in alternate course.
- ii. A queen closer is placed next to the quoin header in each header course to the full thickness of the wall to create bond.
- iii. Each alternate header lies centrally over a stretcher of the stretcher course.
- iv. If the wall thickness is in multiples of an even number of half bricks the same coarse will show either headers (or) stretchers on both the face and back.
- v. If the wall thickness is in multiples of an uneven number of half bricks, the same course will show headers on the face and stretchers on the back (or) stretcher on the face and headers on the back.
- vi. Continuous vertical joints are avoided. For walls having thickness of two bricks (or) more the interior should be filled with headers only.

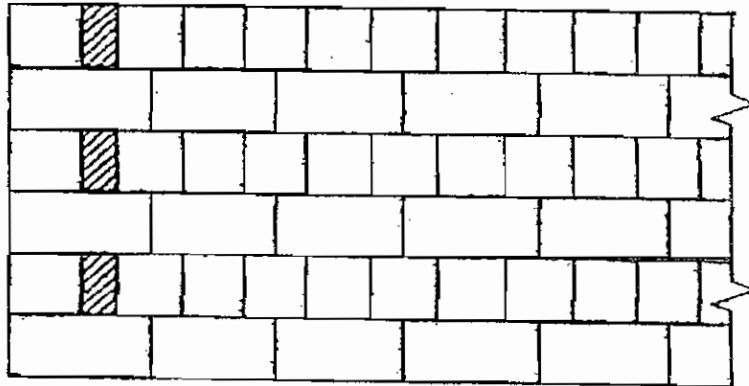

Elevation

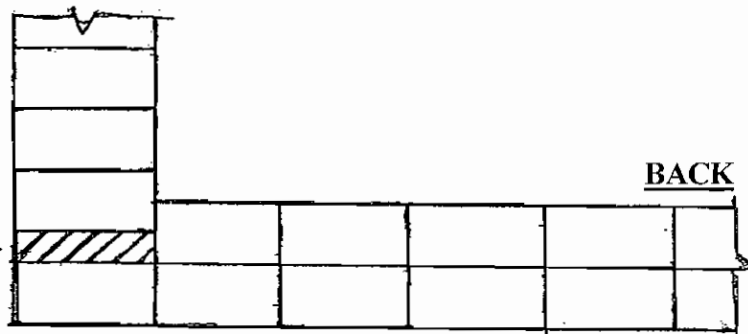

Plan of Stretcher Course

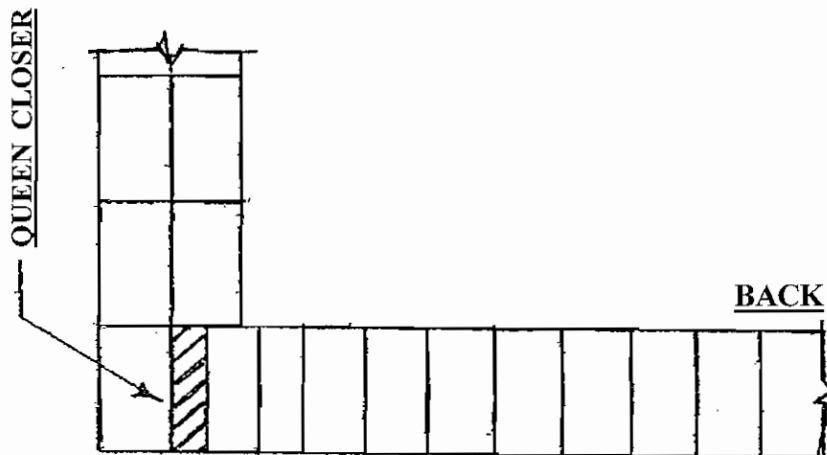

Plan of Header Course

QUEEN CLOSER

One Brick Wall - 20 cm

ARRANGEMENT OF BRICKS BY ENGLISH BOND



## **11.CONSTRUCT A BRICK MASONRY IN FLEMISH BOND FOR A ONE BRICK WALL**

### **ARRANGEMENT OF BRICKS BY FLEMISH BOND**

#### **Aim**

To know the arrangement of brick for 200mm thick wall at right angled corner in Flemish bond.

#### **Tools required**

1. Bricks
2. Mortar
3. Trowel
4. Straight edge
5. Plumb bob
6. Spirit level
7. Trisquare

#### **Procedure**

##### **Features Flemish bond**

- i. It consists of headers and stretchers placed alternately in every course.
- ii. A queen closer is placed next to the quoin header in alternate course to create bond.
- iii. A header in any course is at the centre of a stretcher in the course below it.
- iv. If the wall thickness is in multiples of an uneven number of half bricks, more brick bats are to be used.
- v. A large number of 5 cm lap joints occurs in this bond.
- vi. This bond has lesser strength when compared with English Bond.  
There may be a chance for occurring vertical joints.

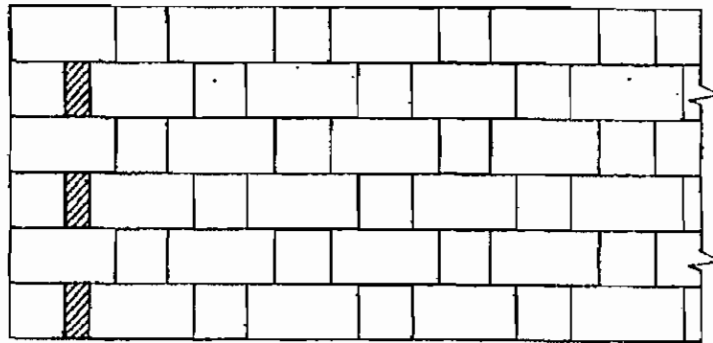

**Front Elevation**

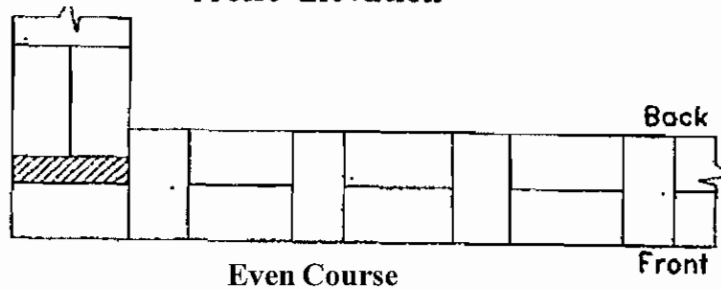

**Even Course**

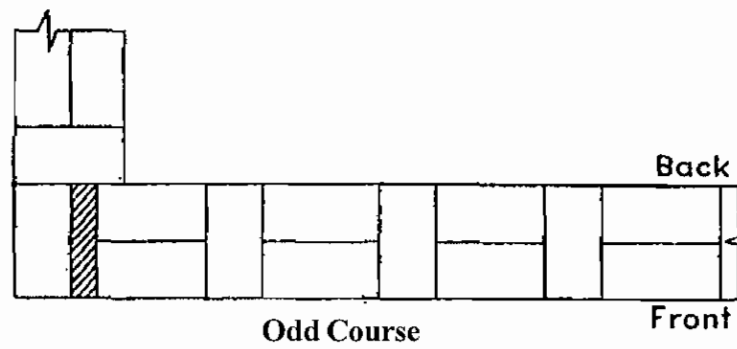

**Odd Course**

**One Brick Wall in Flemish bond**

**ARRANGEMENT OF BRICKS BY FLEMISH BOND**

## 12. WHITE AND COLOUR WASHING FOR A PLASTERED SURFACE

### WHITE AND COLOUR WASHING

#### Aim

To paint the plastered surface and know the technique involved in it.

#### Definition

1. It gives a clean and beautiful surface.
2. It is also used as a disinfectant
3. It gives brightness to the interior surface of the room

#### Procedure

##### a). Preparation of white wash

Slaked lime is dissolved with water and strained through a clean coarse cloth.

2 Kg/m<sup>3</sup> of gum dissolved in hot water is then added to it.

Small amount of Blue is added to it to get brightness.

##### b) Preparation of surface

The surface should be cleaned

In case of rewhite washing all loose materials and scales should be scrapped off.

The surface should be kept wet.

All the holes are to be filled with putty.

All the greasy spots and smoke should be cleaned well.

##### c) Method of white washing

Usually two or three coats are applied for new work.

The second coat is applied after the first coat is dried.

The unpainted surfaces are covered by this.

One stroke is given from top downwards and other from to right to left.

##### d) Method of colour washing

The surface is cleaned and got wet.

The first coat is applied with white cement using good brushes.

The second coat is applied with coloured cement dissolved in water in opposite direction of the first coat.

The third coat is applied after these coats are dried.

Water should be sprinkled on the surface for three days to cure the surface.

## **13. STUDY OF STEEL FABRICATION FOR A LINTEL**

### **LINTEL CUM SUNSHADE**

#### **Aim**

To know the technique involved in the arrangement of reinforcement for lintel cum sunshade.

#### **Definition**

##### **Lintels**

Lintels are construct over the door, window and ventilator openings to distribute the loads to wall below it. It is also used to support the sunshade. The top rods of the beam are known as Hanger bars, and the bottom rods are known as main rods. The bottom reinforcements are used to balance the tensile stresses formed in it. Stirrups are used to support the shear force.

##### **Sunshade**

The rods which are produced from the lintel are called as main rods and the perpendicular rods to the main rods are called as distributors. The thickness of the sunshade must be more than the suspended end to balance the bending moment produced there. The slope of the sunshade is used for easy drain of rain water.

#### **Materials required**

1. Hammer
2. Chisel
3. Bar bending tool
4. Main rods
5. Distributor rods
6. Stirrups
7. Binding wire

#### **Procedure**

1. Read carefully the reinforcement details given by the Engineer.
2. Prepare the stirrups with proper height and breadth in required numbers.
3. Cut the main rods, distributors and hanger bars to required length.
4. Tie the rods with the stirrups as shown in the diagram using binding wire.
5. Thus the reinforcement is arranged for a lintel cum sunshade.

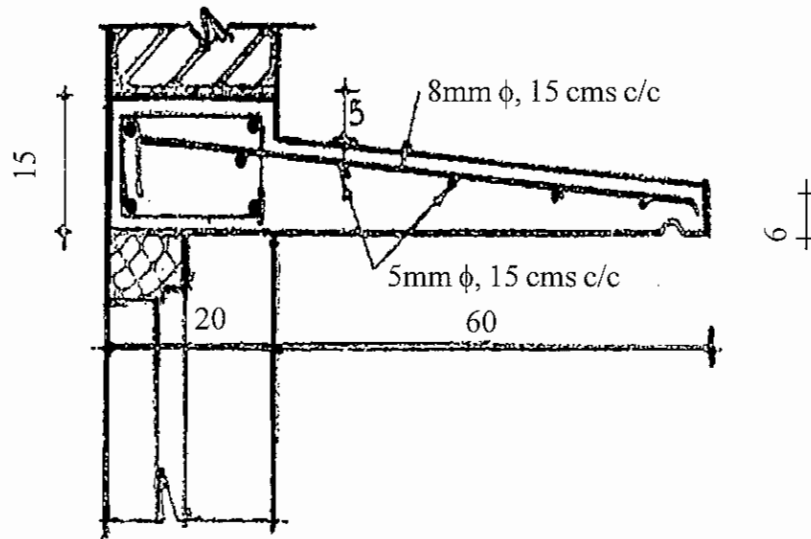

**LINTEL WITH SUNSHADE**

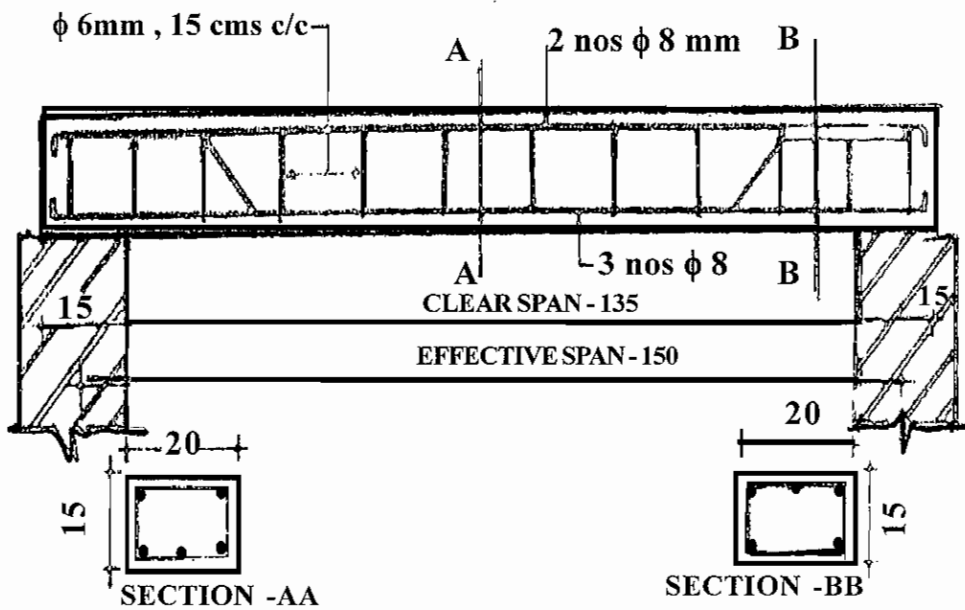

**LINTEL**

## **14. STUDY OF STEEL FABRICATION FOR A ONE WAY SLAB.**

### **ONEWAY SLAB**

#### **Aim**

To know the technique involved in the arrangement of reinforcement.

#### **Definition**

Oneway slabs are designed in the places where the ratio of length and breadth is equal to or more than two.

The main rods are placed at the shorter span to balance the bending moment and the distributors are placed at the longer span perpendicular to the main rods. Normally 10mm (or) 12 mm dia rods are used as main rods and 6 mm (or) 8 mm dia rods are used as distributors. The spacings should be adjusted according to the amount of bending moment produced in the slab.

#### **Materials required**

1. Hammer
2. Chisel
3. Bar bending tool
4. Main rods
5. Distributor rods
6. Stirrups
7. Binding wire

#### **Procedure**

1. Read carefully the reinforcement details given by the engineer.
2. Cut the main rods and distributors to the required length.
3. Crank the main rods at the required distance and height.
4. Place the main rods and distributors at the determined spacings and tie it tightly using binding wire.
5. Check the spacings.
6. Thus the reinforcement is arranged for a one way slab.

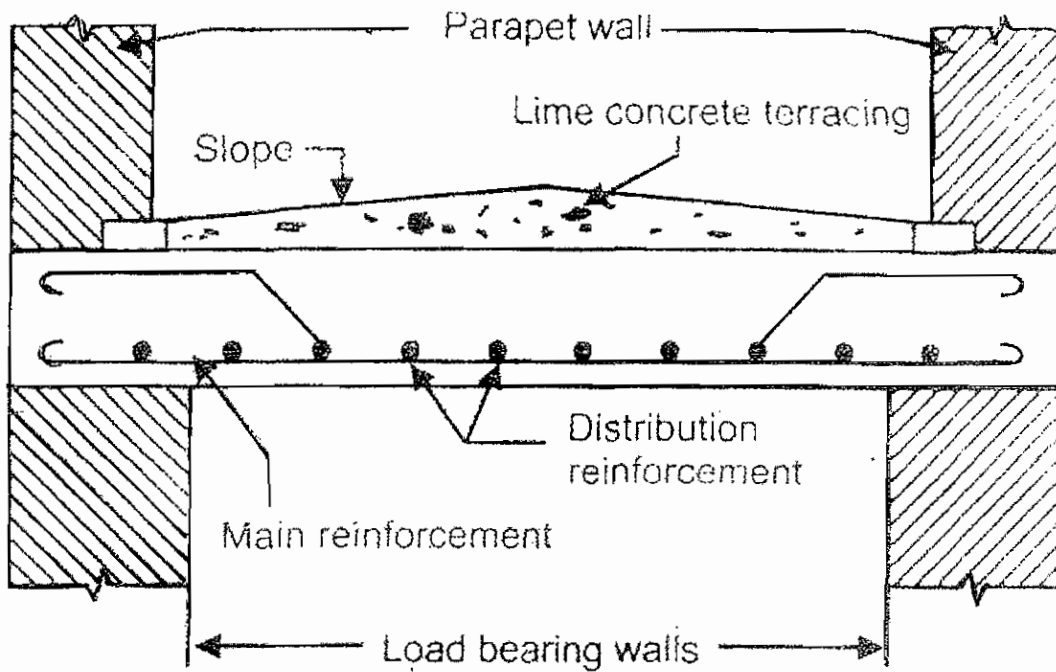

**ONE WAY SLAB**